

MPFA-60

MPFA MAGNETIC SEPARATOR & PAPER FILTER

FEATURES:

1. Applicable to both ferrous and non-ferrous particles.
2. Filtration effect depends on paper accuracy.
Choose from 50 μ , 30 μ and 15 μ .
3. Rough filtration for ferrous particle by magnetic separator and fine filtration for non-ferrous or smaller particle by paper filter.

Remark:

1. Standard accessory: one paper roll.
2. Special specification is available.

APPLICATION:

- | | |
|---------------------------------------|---------------------------|
| 1. Surface Grinding Machine | 5. Tread Grinding Machine |
| 2. Centerless Grinding Machine | 6. Gear Grinding Machine |
| 3. Internal/External Grinding machine | 7. Polisher |
| 4. Honing machine | |

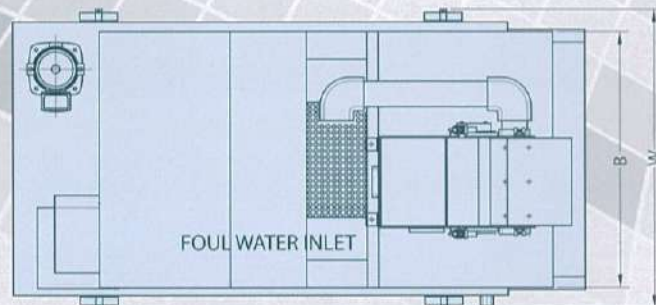

DIMENSION DIAGRAM -MPFA

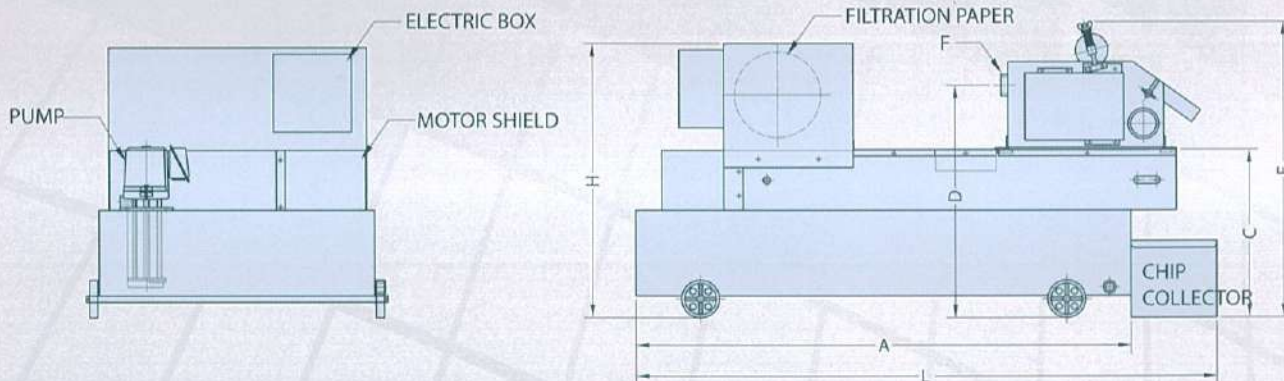

SPECIFICATION

MODEL	CAPACITY L/MIN	TANK VOL. (L)	L	A	B	C	D	E	F	H	W	PUMP (HP)		MOTOR	FILTER PAPER	Note
												HP	OUTLET			
MPFA-20	20	100	1050	850	600	400	550	705	PF1 1/2"	660	720	1/8	PF1 1/2"	25W		WHEEL
MPFA-40	40	120	1200	1000	600	400	550	705	PF2"	660	720	1/8	PF1 1/2"	25W	W: 500MM	
MPFA-60	60	140	1350	1150	600	400	555	705	PF2"	660	720	1/8	PF1 1/2"	25W	L: 90M	
MPFA-80	80	160	1500	1300	600	400	555	705	PF2"	660	720	1/4	PF3/4"	25W		
MPFA-120	120	210	1500	1300	800	400	590	750	PF3"	740	920	1/2	PF3/4"	40W	W: 700MM	NO WHEEL
MPFA-160	160	260	1800	1600	800	400	605	750	PF3"	740	920	1/2	PF3/4"	40W	L: 90M	
MPFA-240	240	440	1550	1350	1060	430	640	915	PF3"	740	1330	1	PF1"	60W	W: 1000MM	NO WHEEL
MPFA-360	360	640	2150	1950	1060	430	640	915	PF4"	740	1330	1	PF1"	60W	L: 90M	
MPFA-500	500	980	3240	2950	1060	430	640	915	PF5	740	1330	1X2	PF1"X2	60W		

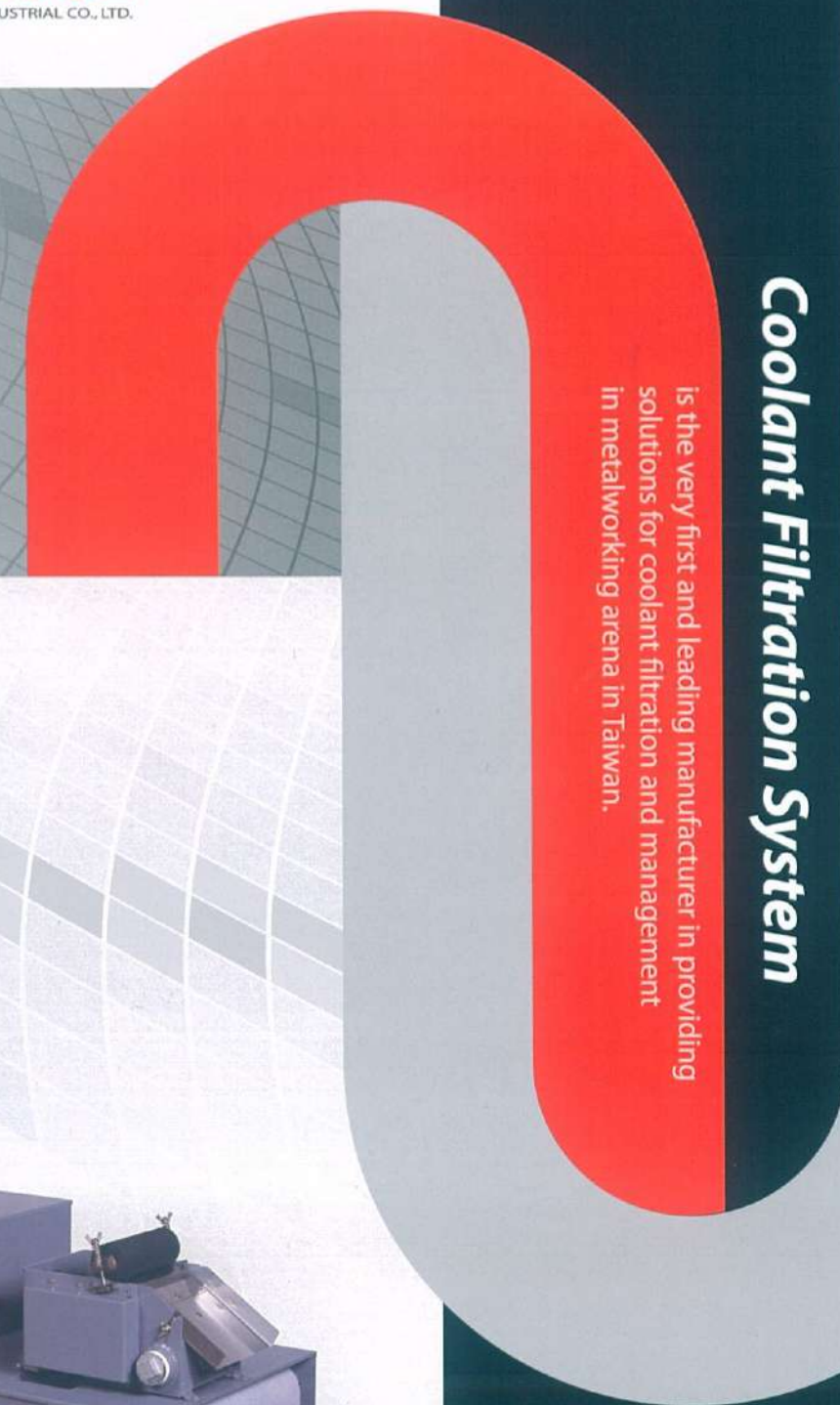

Coolant Filtration System
 is the very first and leading manufacturer in providing solutions for coolant filtration and management in metalworking arena in Taiwan.

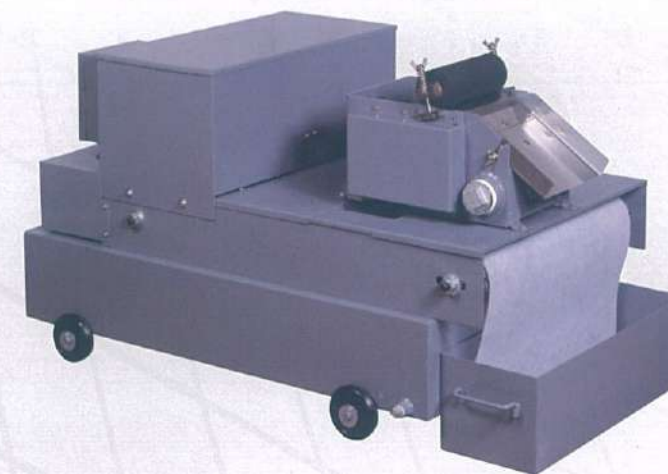

Magnetic Separator & Paper Filter

Combine Magnetic Separator and Paper Filter and be able to filter ferrous and non-ferrous particles. Use Magnetic Separator as pre-filter to remove large and ferrous particles to save cost on filter paper and increase filtration fineness.

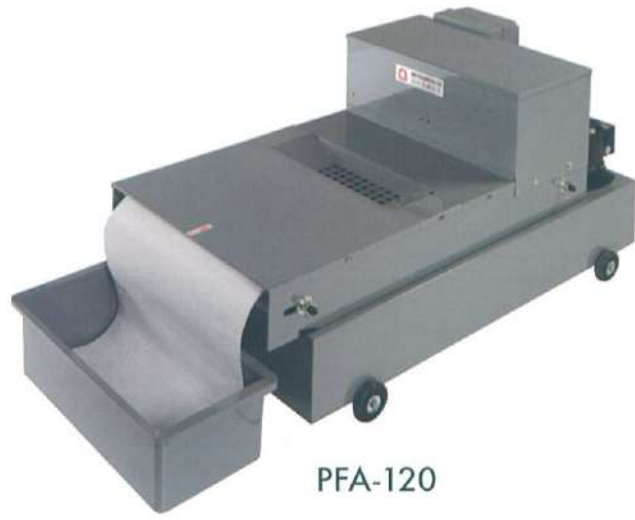

PFA-120

PFA
PAPER FILTER

FEATURES:

1. Applicable to both ferrous and non-ferrous particles.
2. Filter paper moves forward automatically when contaminants accumulate and clog it.
3. Filtration effect depends on paper accuracy. Choose from 50μ, 30μ and 15μ.
4. Not suitable for heavy machining for the sake of paper consumption. Use magnetic separator as pre-filter to reduce paper consumption.

Remark:

1. Standard accessory: one paper roll.
2. Special specification is available.

APPLICATION:

- | | |
|---------------------------------------|---------------------------|
| 1. Surface Grinding Machine | 5. Tread Grinding Machine |
| 2. Centerless Grinding Machine | 6. Gear Grinding Machine |
| 3. Internal/External Grinding machine | 7. Polisher |
| 4. Honing machine | |

DIMENSION DIAGRAM

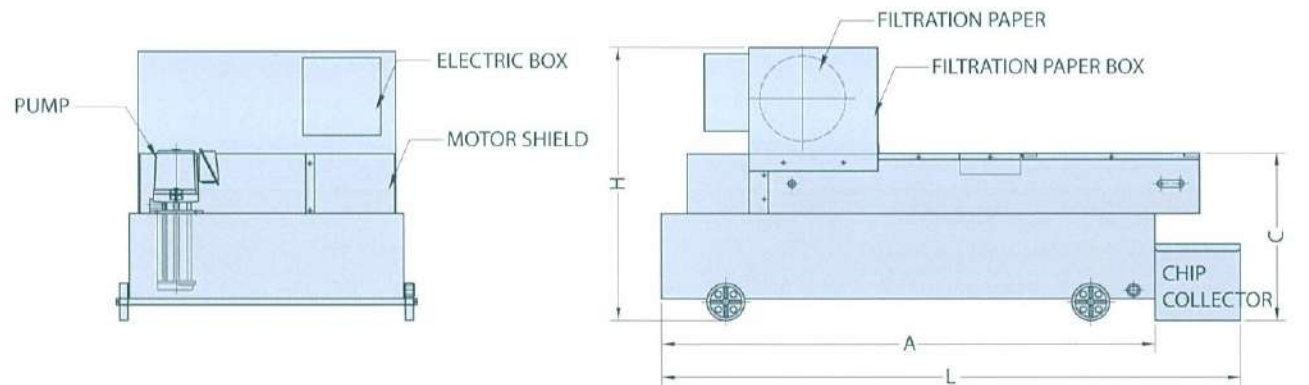

SPECIFICATION

MODEL	CAPACITY L/MIN	TANK VOL. (L)	L	A	B	C	W	H	PUMP (HP)		MOTOR	FILTER PAPER	Note
									HP	OUTLET			
PFA-20	20	100	1050	850	600	400	720	660	1/8	PF1/2"	25W	W: 500MM L: 90M	WHEEL
PFA-40	40	120	1200	1000	600	400	720	660	1/8	PF1/2"	25W		
PFA-60	60	140	1350	1150	600	400	720	660	1/8	PF1/2"	25W		
PFA-80	80	160	1500	1300	600	400	720	660	1/4	PF3/4"	25W		
PFA-120	120	210	1500	1300	800	400	920	740	1/2	PF3/4"	40W	W: 700MM L: 90M	
PFA-160	160	260	1800	1600	800	400	920	740	1/2	PF3/4"	40W		
PFA-240	240	440	1550	1350	1060	430	1330	740	1	PF1"	60W	W: 1000MM L: 90M	NO WHEEL
PFA-360	360	640	2150	1950	1060	430	1330	740	1	PF1"	60W		
PFA-500	500	980	3240	2950	1060	430	1330	740	1X2	PF1"X2	60W		

MCA
MAGNETIC SEPARATOR



MCA-60



MCA-500

FEATURES:

1. Most economical application to heavy machining for ferrous metal.
2. No filter media consumption. Serve as rough filtration in process.

Remark:

1. Standard accessories:
 - a. Sludge box 1pc
 - b. Plugs 2 pcs
 - c. Elbow 1 pc
 - d. Steel Tube 3pcs
2. Custom specification is available.

APPLICATION:

- | | |
|---------------------------------------|---------------------------|
| 1. Surface Grinding Machine | 5. Tread Grinding Machine |
| 2. Centerless Grinding Machine | 6. Gear Grinding Machine |
| 3. Internal/External Grinding machine | 7. Polisher |
| 4. Honing machine | |

DIMENSION DIAGRAM MCA-20~160

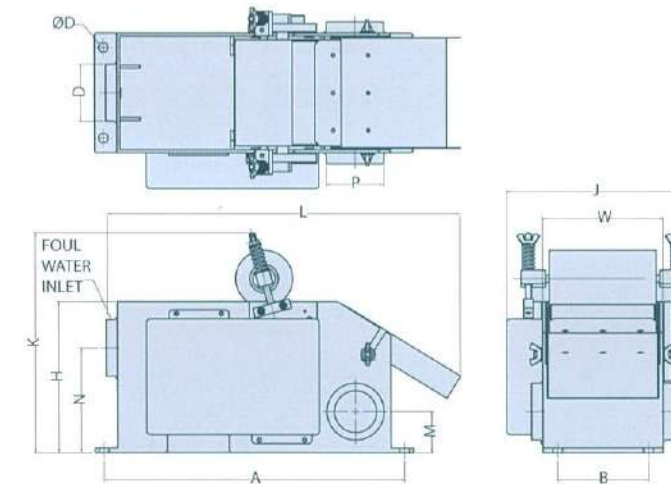

DIMENSION DIAGRAM MCA-240~500

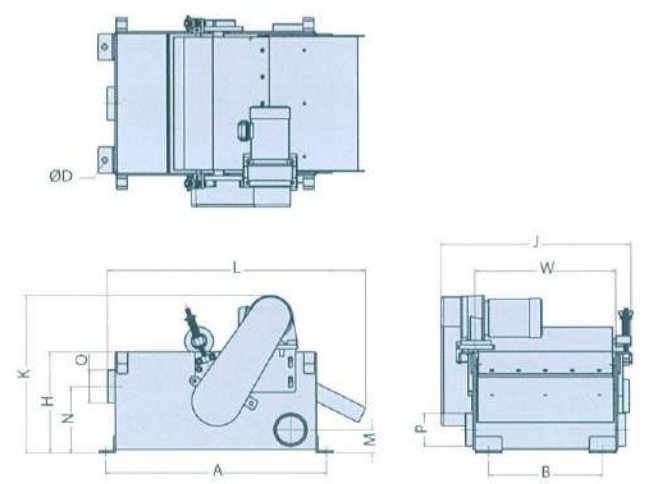

SPECIFICATION

MODEL	CAPACITY L/MIN	L	W	H	M	N	A	B	D	J	X	INLET O	OUTLET P	MOTOR
MCA-20	20	464	130	205	65	145	398	100	11	230	300	PF1 1/2"	PF1 1/2"	220V 3Ø 25W
MCA-40	40	464	150	205	65	145	398	120	11	250	300	PF 2"	PF 2"	220V 3Ø 25W
MCA-60	60	464	206	205	60	150	398	176	11	306	300	PF 2"	PF 2"	220V 3Ø 25W
MCA-80	80	464	242	205	60	150	398	212	11	342	300	PF 2"	PF2 1/2"	220V 3Ø 25W
MCA-120	120	530	270	245	68	185	456	230	11	380	345	PF 3"	PF 3"	220V 3Ø 40W
MCA-160	160	530	354	245	68	185	456	314	11	464	345	PF 3"	PF 3"	220V 3Ø 40W
MCA-240	240	820	420	305	70	200	660	340	17	585	480	PF 3"	PF 3"	220V 3Ø 100W
MCA-360	360	820	620	305	80	200	660	540	17	785	480	PF 4"	PF 4"	220V 3Ø 100W
MCA-500	500	820	820	305	90	200	660	740	17	985	480	PF 5"	PF 5"	220V 3Ø 100W
MCA-800	800	820	1220	305	90	200	660	1140	17	1385	480	PF 5"	PF 5"	220V 3Ø 200W
MCA-1000	1000	970	1520	405	110	285	810	1440	17	1385	580	PF 6"	PF 6"	220V 3Ø 200W