

SPEEDIO

U500Xd1

Universal Compact Machining Center



U

Universal Compact Machining Center performs universal indexing, encouraging process integration

Equipped with a newly developed tilting rotary table with a maximum jig area of 500 mm in diameter.

Combination with a 28-tool magazine enables multi-face machining that breaks the conventional concept of #30 machines.

Cutting Out the Waste *SPEEDIO*



U500Xd1



Basic specifications

Max. spindle speed (min ⁻¹)	10,000 / 16,000 (optional)
Travels (X, Y, Z) (mm)	X500 Y400 Z300
Travels (A, C) (deg.)	A: 120~30, C: 360
Tool storage capacity (pcs.)	14 / 21 / 28
Rapid traverse rate (X, Y, Z) (m/min)	X / Y / Z 50 / 50 / 56
Indexing speed (A, C) (min ⁻¹)	A / C 50 / 75
Required floor space (mm)	1,560 x 2,026
BT dual contact spindle	Optional
Coolant Through Spindle	Optional

Expands process flexibility to the fullest Provides a broader range of applications

SPEEDIO's high-speed performance and process integration through multi-face machining enhance productivity at customers' premises more than ever before.

One-clamp operation achieves highly efficient and highly accurate machining in various industries.

Automobile



EV gearbox housing
Aluminum alloy
Size: 305 x 260 x 90



EV motor case cover
Aluminum alloy
Size: 400 x 350 x 40

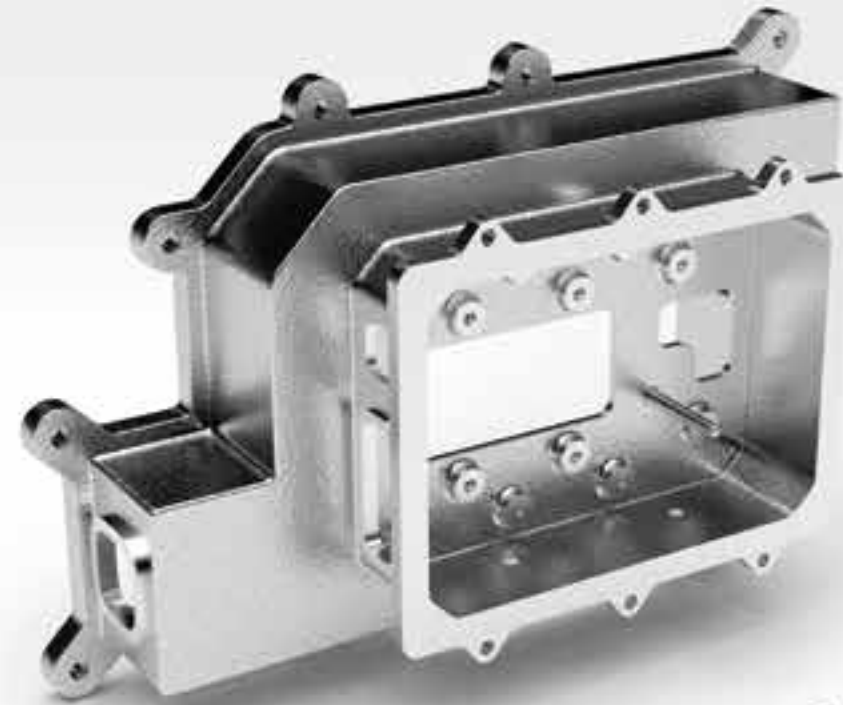

EV inverter case
Aluminum alloy
Size: 400 x 280 x 150



Steering rack housing
Aluminum alloy
Size: 350 x 170 x 120

Aircraft



Aircraft parts
Aluminum alloy
Size: 300 x 250 x 100

Medical



Bone plate
Ti-6Al-4V
Size: 280 x 50 x 3

Equipped with tilting rotary table with jig area of $\phi 500$ New structure for process integration with less space

Less space achieved although the machine is equipped with a high-speed and highly accurate tilting rotary table with ample jig area and a newly developed 28-tool magazine.

One-clamp machining encourages process integration.

Tilting rotary table

Provides ample jig area of $\phi 500 \times H270$ to meet multi-face machining for medium-sized workpieces.

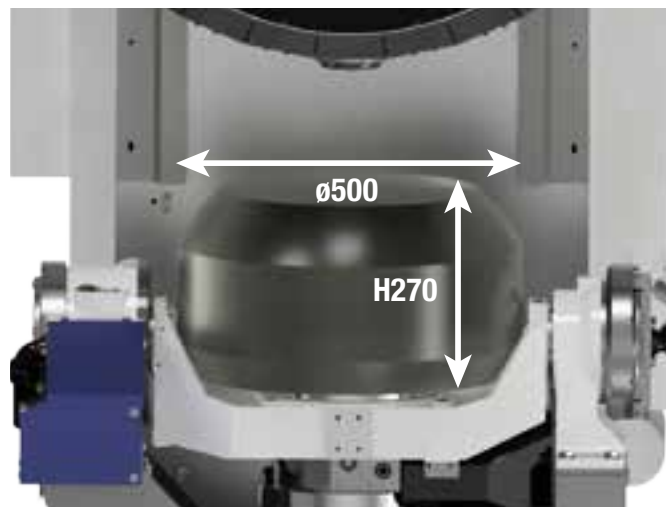

Max. loading capacity **100kg**

28-tool magazine

A newly developed compact drum type 28-tool magazine takes over fast tool change performance.

* A 14-tool magazine or a 21-tool magazine can be also selected.



Max. tool weight **4kg***

* Parameter setting needs to be changed.

Machining area in Z/Y-axes directions

Ample jig/workpiece/tool area secured in the Z-axis direction. (Distance between table top and spindle nose end: 445 mm)
The Y-axis travel range has been shifted from the center of the tilt axis to secure sufficient machining area when the tilt axis is at 90 degrees. (Y-axis travel when A-axis is at 90 degrees: 270 mm)

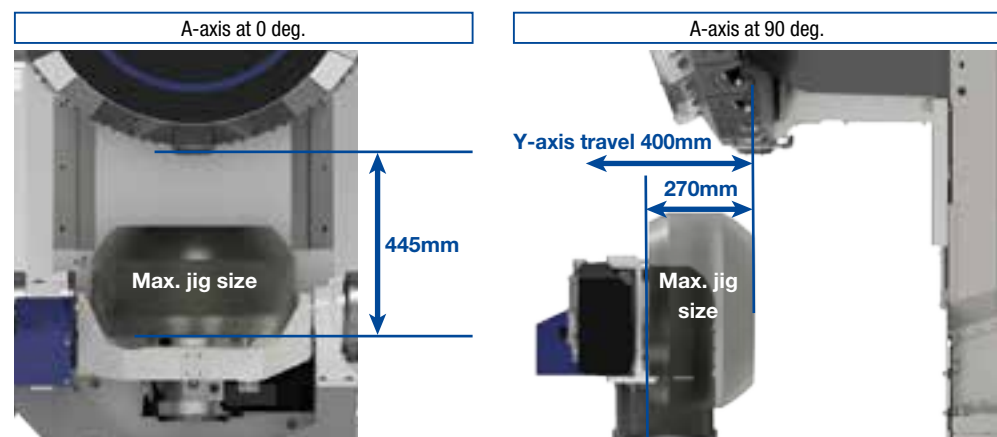

Compact design to save space

Despite a jig area of $\phi 500$ and even when a 28-tool magazine is mounted, the machine width is the same as when a 14-tool magazine is mounted.



Equipped with tilting rotary table that uses roller gear cam

Roller gear cam mechanism is used for A and C axes, achieving high retention strength and backlash-free high-speed and highly accurate indexing.

The rotary range of A-axis (tilt axis) is -30 deg. to 120 deg. suitable for a wide variety of machining.

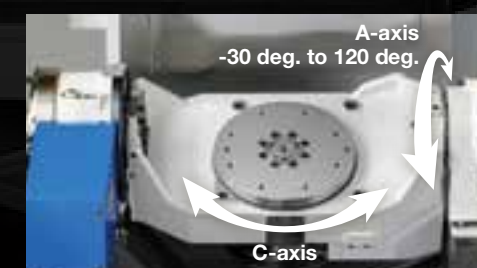

Max. rotary speed
A-axis **50min⁻¹** C-axis **75min⁻¹**

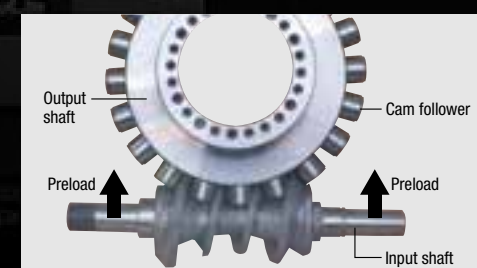

0 to 90-deg. indexing time
A-axis **0.9s** C-axis **1.2s**

Untiring pursuit of high productivity

Reduction in waste by optimizing control through machine/controller integrated development

Pursuing fast acceleration and quick response through machine/controller integrated development and optimizing control with the new "CNC-D00" controller drive machine performance to the limit to provide high productivity.

Non-stop ATC

High-speed tool change has been achieved by faster and optimized spindle start/stop, Z-axis up/down, and magazine operation. Tools up to 3 kg can be changed in the shortest time. Tools up to 4 kg can also be changed with minimal increase in time.

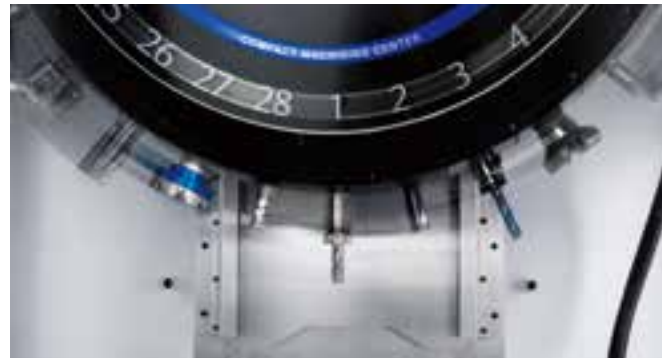

28-tool magazine			
Standard tool	Chip-Chip	1.3s	Tool-Tool 0.7s
4 kg tool*	Chip-Chip	1.4s	Tool-Tool 0.8s

* Parameter setting needs to be changed.

Simultaneous operation

Wasted time has been reduced by simultaneously performing tool change and positioning X/Y and A/C axes.



High acceleration/deceleration spindle

Using a low inertia spindle and high acceleration/deceleration spindle motor has achieved faster spindle start/stop.



Spindle start/stop time **0.2s or less**

High-speed and high-acceleration Z axis

As the Z-axis moves frequently, the highest acceleration in its class has been achieved, contributing to reduction in cycle time together with the Z-axis rapid traverse rate of 56 m/min.



Z-axis acceleration Max. **2.2G** Z-axis rapid traverse rate **56m/min**



Highly rigid machine structure and highly efficient spindle motor enable a broad range of machining

Reliable and trustworthy machine structure has been achieved.

Equipped with a highly efficient spindle motor that demonstrates sufficient torque from the low- to high-speed range.

Achieves highly efficient machining in various industries, from automobile to general machinery, medical, and aircraft industries.

XYZ axes based on S500Xd1

The main unit of the machine and XYZ-drive system are based on the bestselling S500Xd1 model. Highly rigid structure and high-speed operation have been achieved.

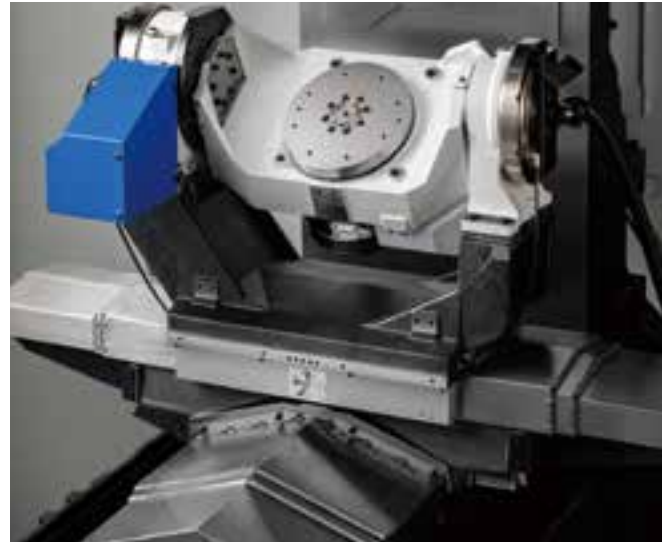

Highly efficient spindle motor

A spindle motor with high torque in the medium- and high-speed range is used to achieve high-speed and highly efficient machining of aluminum or iron.

10,000 min ⁻¹ (standard)	Max. torque 40Nm	Max. output 18.9kW
16,000 min ⁻¹ (optional)	Max. torque 27Nm	Max. output 15.4kW

7 MPa Coolant Through Spindle (CTS) (optional)

The CTS option can be selected from 3 MPa or 7 MPa. With this option, the machine can operate to its fullest potential in high-speed drilling or peck drilling.

High inertia mode

High inertia mode is available for the tilting rotary table so that jigs for heavy or irregular workpieces can be mounted.

* Parameter setting needs to be changed.

High clamp torque

Both A and C axes are provided with high clamp torque, demonstrating high retention strength even in high-load machining. Machining with more stringent cutting conditions is possible, improving production efficiency.

A-axis clamp torque ^{*1}	810Nm
C-axis clamp torque ^{*1}	560Nm

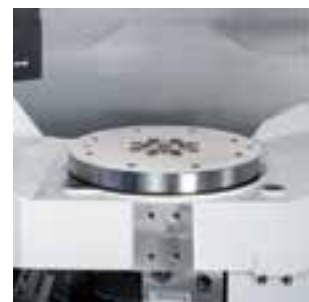

*1. The value of mechanical clamp (at 0.5MPa) plus servo clamp

Accessibility and workability

Accessibility has been enhanced so that operators can perform setup including workpiece change without any strain.



From front of machine to table
320mm

Machining capability

		ADC	Cast iron	Carbon steel
Drilling	10,000min ⁻¹	D32 x 0.2 (1.26 x 0.008)	D28 x 0.15 (1.1 x 0.006)	D25 x 0.1 (0.98 x 0.004)
	16,000min ⁻¹	D24 x 0.2 (0.94 x 0.008)	D22 x 0.15 (0.87 x 0.006)	D18 x 0.1 (0.71 x 0.004)
Tapping	10,000min ⁻¹	M27 x 3.0 (1-8UNC)	M24 x 3.0 (7/8-9UNC)	M16 x 2.0 (5/8-11UNC)
	16,000min ⁻¹	M22 x 2.5 (7/8-9UNC)	M18 x 2.5 (5/8-11UNC)	M14 x 2.0 (1/2-13UNC)
Facing	10,000min ⁻¹	960 (58.6)	74 (4.5)	54 (3.3)
	16,000min ⁻¹	660 (40.3)	64 (3.9)	46 (2.8)

* Data obtained from tests conducted by Brother.

* These values are when the A-axis is at 0 degrees and X/Y axes are at their travel center. The above machining capability may not be achieved depending on conditions, including usage environment, tools in use, and coolant.



Equipped with new “CNC-D00” controller Enhanced usability with 15-inch LCD touch panel

Intuitive operation is possible with new apps and vertical touch panel screen. Relevant functions are grouped according to purpose, such as setup and machining, leading to efficient operation. Production and operation states are visualized, allowing faster understanding. Waste-free operation is possible in setup, machining adjustment, production, and recovery process, leading to improved work efficiency and operating rate.

Home screen

Information required for production, such as workpiece counter and tool life, is collected on the home screen. Shortcut keys are provided for screens frequently used so you can open them by one touch.



New user interface

Usability has been greatly improved by grouping relevant functions, creating new support apps that are intuitive with improved operability and visibility, providing useful accessories (calculator, notebook, file viewer etc.), and making operation on conventional screens possible on the touch panel.



List of support apps Conventional screen (position screen)

Setup support

Equipped with functions to easily perform setup, such as an ATC tool app that enables all magazine tool settings to be performed on one screen, menu programming that enables you to create NC programs by following instructions on the screen, and an on-screen help function.



ATC tool app

Machining adjustment support

Equipped with functions to easily perform optimal machining adjustment to improve productivity, such as a machining parameter adjustment app that enables you to easily adjust parameters according to machining details and a machining load waveform display/saving function.

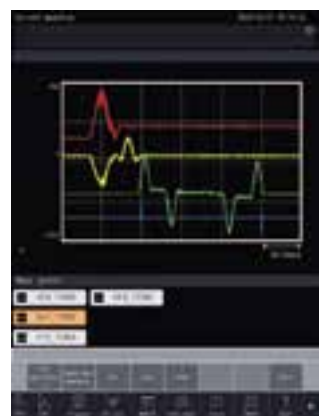

Waveform display app

Production support

Equipped with functions to improve the operating rate, such as real time tool monitoring to eliminate defects, displaying production performance, power consumption etc. as a graph, and PLC/network functions to meet peripheral equipment and automation requirements.



Production performance app

Recovery support

Equipped with functions to prevent failure or ensure quick recovery, such as maintenance time notice, displaying details when an alarm occurs, and guidance for recovery/check work.



Recovery support app

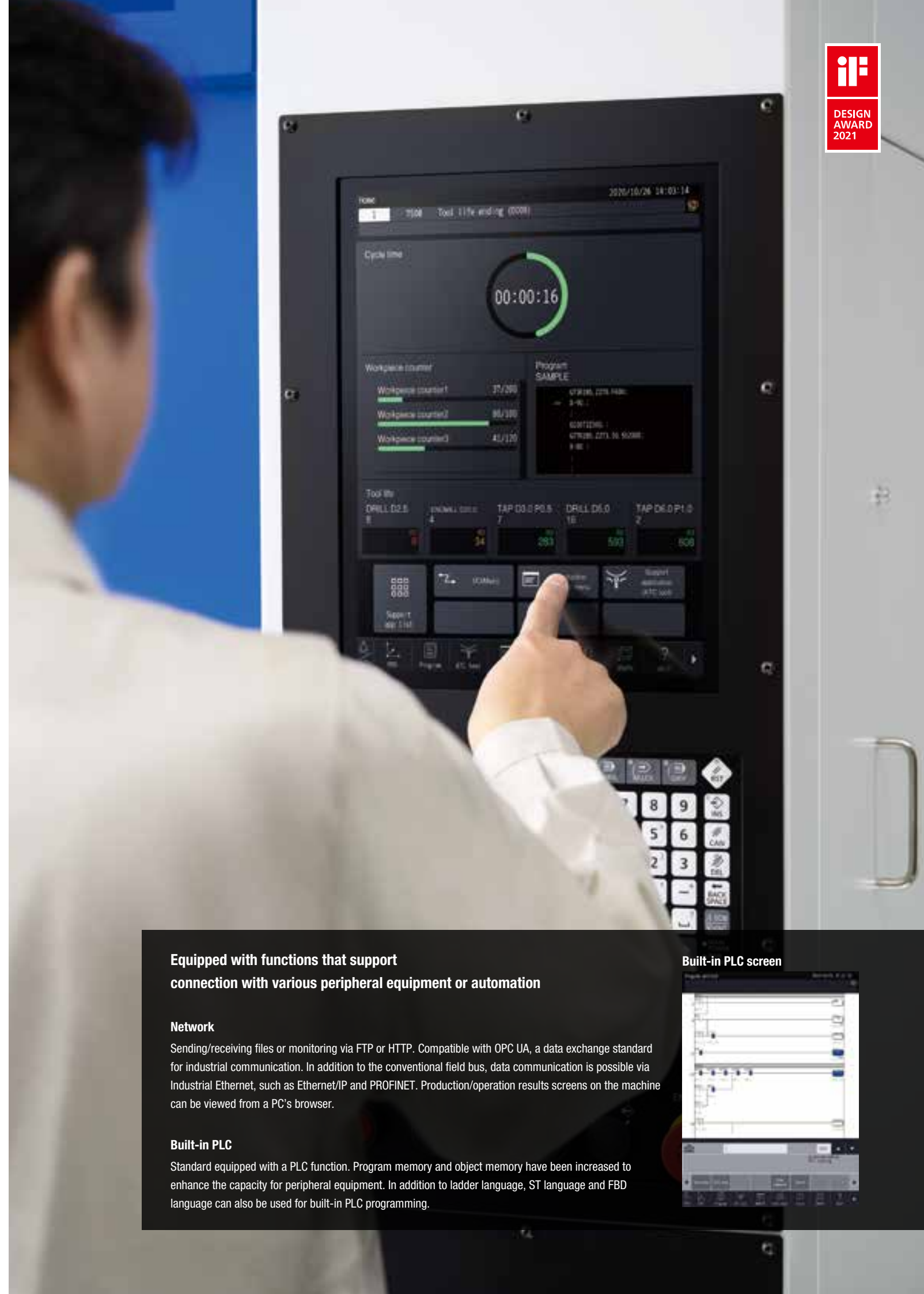

Equipped with functions that support connection with various peripheral equipment or automation

Network
Sending/receiving files or monitoring via FTP or HTTP. Compatible with OPC UA, a data exchange standard for industrial communication. In addition to the conventional field bus, data communication is possible via Industrial Ethernet, such as Ethernet/IP and PROFINET. Production/operation results screens on the machine can be viewed from a PC's browser.

Built-in PLC
Standard equipped with a PLC function. Program memory and object memory have been increased to enhance the capacity for peripheral equipment. In addition to ladder language, ST language and FBD language can also be used for built-in PLC programming.



Built-in PLC screen

Earth-friendly machine with reliability that ensures high productivity

High reliability has been achieved by thorough evacuation and efficient handling of chips, and maintenance functions to prevent failures. Low power and air consumption greatly reduces CO₂ emissions, creating an earth-friendly plant environment.

Tank with cyclone filter and no consumables (special option for CTS)

Clean coolant is returned to the clean tank through another tank with a cyclone filter that removes fine chips. Coolant is kept clean this way to reduce the filter change frequency and extend the service life of the pump.

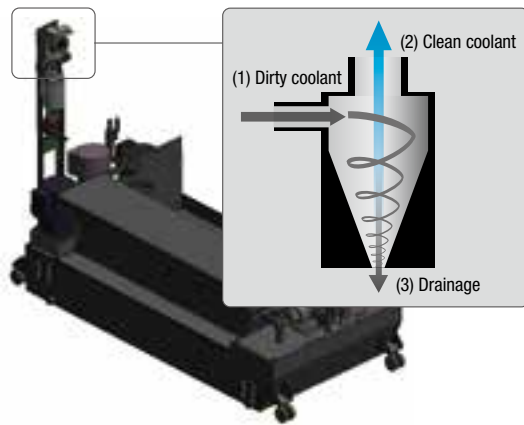

Low power consumption

In addition to the low inertia spindle and highly efficient spindle motor, the machine is equipped with various energy saving functions to lower power consumption.

Power consumption app

Current and past power consumption can be checked.



Low air consumption

Air related functions have been reviewed and optimized to eliminate any waste, leading to reduction in air consumption.

Air purge

A highly airtight structure achieved through repeated flow rate analysis reduces the amount of air used.



Spindle air blow

Amount of air used is reduced by discharging three times the conventional volume of air only when required.

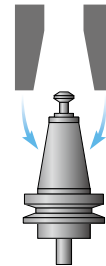

Reliability and maintenance functions for prevention of defects/failures and quick recovery

To maintain productivity at plants, the machine is equipped with many functions that can prevent possible defects in daily production sites, such as tool abrasion, omission of tool attachment, and re-machining of the same workpiece, and functions that assist with recovery in the case of machine failure or other problems.

ATC tool monitoring

The presence of a spindle tool is checked before and after tool change without using a sensor.



Machining load monitoring

Machining load applied to the spindle is monitored to issue an alarm when the load is not within the preset range.



Maintenance notice

Notifies operators of maintenance related issues in advance, such as greasing time.



Alarm log

Displays alarm log details to help identify the cause.



Prevention of chip problems

Thorough chip evacuation/removal prevents chip problems, improving reliability.

Improvement of chip evacuation performance

Roof-shape telescopic covers are used for the XY-axes to help chips flow smoothly. The shape for the chip flow path from the machining room to the tank was devised to increase the flow speed. Changing the shape under the Y-axis telescopic cover and increasing the flow rate have improved chip evacuation performance by almost two-fold.

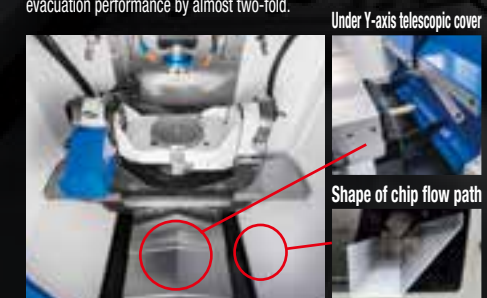

Tool washing, air-assisted type (optional)

Air-assisted high discharge pressure and discharge amount steadily remove chips attached to the tool taper. Stable washing power is achieved, without being affected by filter clogging. Expanding the pump capacity is not necessary, leading to higher energy saving.

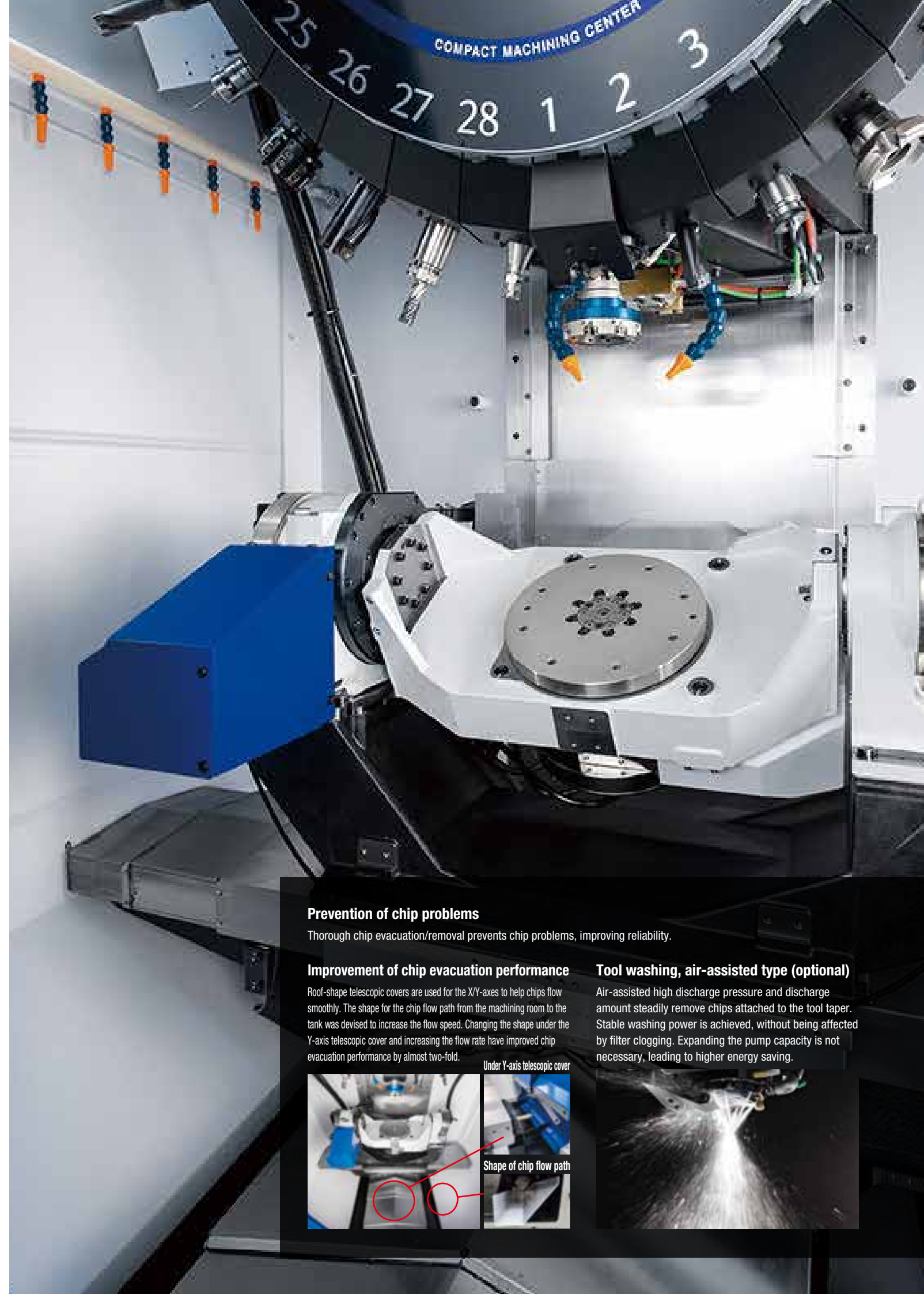



Coolant tank
Can be selected from 50L, 100L, 150L, or 200L according to the purpose. If you need a CTS spec. higher than 1.5 MPa, this will be custom-built.



Coolant Through Spindle (CTS)
Can be selected from 3.0 MPa or 7.0 MPa. Pump and tank are not included.



Head coolant nozzle
Coolant can reliably be applied to the machining section as the tool and nozzles are set in place.



Tool washing, air-assisted type
High discharge pressure and flow rate efficiently remove chips attached to the holder. Equipped with a filter clog warning function.



Signal light (1, 2, or 3 lamps)
LED lamps are used. No maintenance required. Can be tilted to improve visibility.



Automatic oil lubricator
Regularly applies oil to all lubricating points on the tree axes.



Automatic grease lubricator
Regularly applies grease to all lubricating points on the three axes. *Manual greasing is required for the standard specification model.



Automatic door with switch panel 10 holes
A motor-driven door is used, achieving smooth operation.



Rotary joint
Six built-in ports are prepared to make jig mounting easier. 6 ports: Hydraulic (7 MPa), Pneumatic (1 MPa)



Chip shower
Chip shower pipes are located at the upper section inside the machine for more efficient flow, and flexible shower nozzles can be directed to the side of the machine cover or sections where chips tend to accumulate.

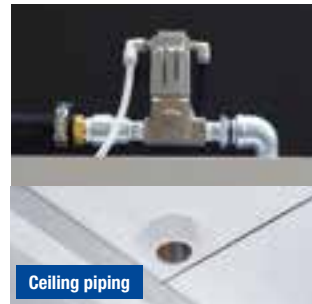

Fixture shower valve unit
Consists of jig washing valves and pipes to the ceiling of the machine. Pipes from the machine to the required location must be prepared by customers.



Cleaning gun
Helps clean the workpiece or chips inside the machine after machining.



Area sensor
Optical area sensors are used. Use area sensors to prevent operators being caught in the automatic door.



Manual pulse generator
A cable is provided for the manual pulse generator, making setup easier. Equipped with emergency stop and enable switches.



Tool breakage detector, touch type
A touch switch type tool breakage detector is available.



Spindle override
Spindle speed can be changed without changing the program.



Top cover
Shutting the opening on the top prevents coolant or chips splashing outside of the machine. A hole for the mist collector is provided.



Side door with transparent window
Makes setup from the side easier. The machining room can be checked through the window. The manual pulse generator can also be operated.



Side cover with transparent window
External light is drawn in to make the inside of the machine brighter and improve visibility.



Work light (right side, left side)
LED lamps are used to extend lamp life and save energy.



Switch panel (8 holes or 10 holes)
Various switches, such as automatic door open/close switches, are set in specific locations. The switch panel (8 holes) is also available so that the position of the manual pulse connector can be changed.



Master on circuit
Master on circuit and switch can be attached. * A switch panel (8 holes or 10 holes) is required separately.

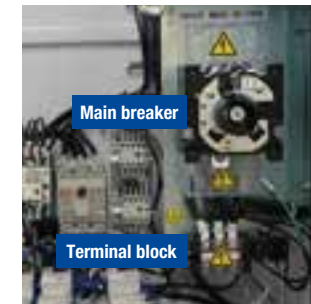

Power supply expansion 50A
The capacity of the main breaker can be increased from 30A to 50A. The size of the relevant wiring increases accordingly. A terminal block for external equipment power supply is provided under the main breaker.



RS232C 25-pin connector
RS232C 25-pin connector can be attached to the side of the control box.

● Please read the instruction manuals and safety manuals before using Brother products for your own safety. When using oil-based coolant or when machining materials which can cause a fire (ex. magnesium, resin), customers are requested to take thorough safety measures against fire. The types of cutting material, cutting tools, coolant, or lubrication oil may have an influence on the machine's lifecycle. For further questions, please contact our sales representative.

● Leave 700 mm between machines as maintenance space.

● When exporting our machine, the machine is deemed to be included in the "applicable listed items" controlled by the Foreign Exchange and Foreign Trade Law of Japan. When exporting the machine, please obtain required permissions, including an export license, from the Ministry of Economy, Trade and Industry (METI) or Regional Bureaus of Economy, Trade and Industry before shipment. When re-selling or re-exporting the machine, you may need to obtain permissions from METI, and the government of the country where the machine is installed.

● When exporting our machine, as a machine conforming to Row 2 of Appended Table 1 of Export Trade Control Order, a relocation detection device is installed on the machine depending on the destination country. After relocating the machine with the detection device, the machine is locked and any operation is temporarily impossible. Please inform your local distributor of machine relocation in advance and apply to perform the release operation of relocated machine.

- Coolant tank
 - 1) Coolant tank, 50L
 - 2) Coolant tank, 100L
 - 3) Coolant tank, 150L
 - 4) Coolant tank, 150L for 1.5 MPa CTS pump with cyclone filter
 - 5) Coolant tank, 200L for 1.5 MPa CTS pump with cyclone filter
- Coolant through spindle (CTS) piping, Max. 3.0 MPa
- Coolant through spindle (CTS) piping, Max. 7.0 MPa
- Head coolant nozzle
- Rotary joint 6 ports
- Chip shower
- Tool washing, air-assisted type
- Fixture shower valve unit
- Cleaning gun
- Mesh basket for collecting chips (2 pcs.)
- Top cover
- Side door with transparent window, right side
- Side cover with transparent window, one side

- Work light (1 lamp for right side, 1 lamp for left side)
- Signal light (1, 2, or 3 lamps)
- Automatic oil lubricator
- Automatic grease lubricator
- Automatic door with switch panel 10 holes
- Area sensor
- Switch panel (8 holes or 10 holes)
- Manual pulse generator with enable switch
- Connector and hook for manual pulse generator with enable switch
- Tool breakage detector, touch type
- RS232C 25-pin connector at control box
- Spindle override
- Master on circuit
- Data protection switch, key type
- Grip cover for 14/21/28-tool magazine
- Parts name sticker set
- Breaker handle cover
- Origin alignment mark

- 100V outlet in control box
- Power supply expansion 50A
- Transformer box
- Specified color
- EXIO board assembly
 - 1) EXIO board, input 32/output 32, additional #1
 - 2) EXIO board, input 32/output 32, additional #2
- PLC programming software for D00
- Industrial network
 - 1) CC-Link, master station
 - 2) CC-Link, remote device station
 - 3) PROFIBUS-DP, slave
 - 4) DeviceNet, slave
 - 5) PROFINET, slave
 - 6) EtherNet/IP, slave
- Memory expansion 3 Gbytes

* The type of coolant may have a significant influence on the machine's lifecycle. It is recommended to use high-lubricity (emulsion type) coolant.

Do not use chemical solution type (synthetic type) coolant, as it may cause damage to the machine.

* When using CTS (Coolant Through Spindle) function, do not use flammable coolant (ex. oil-based type).

U500Xd1

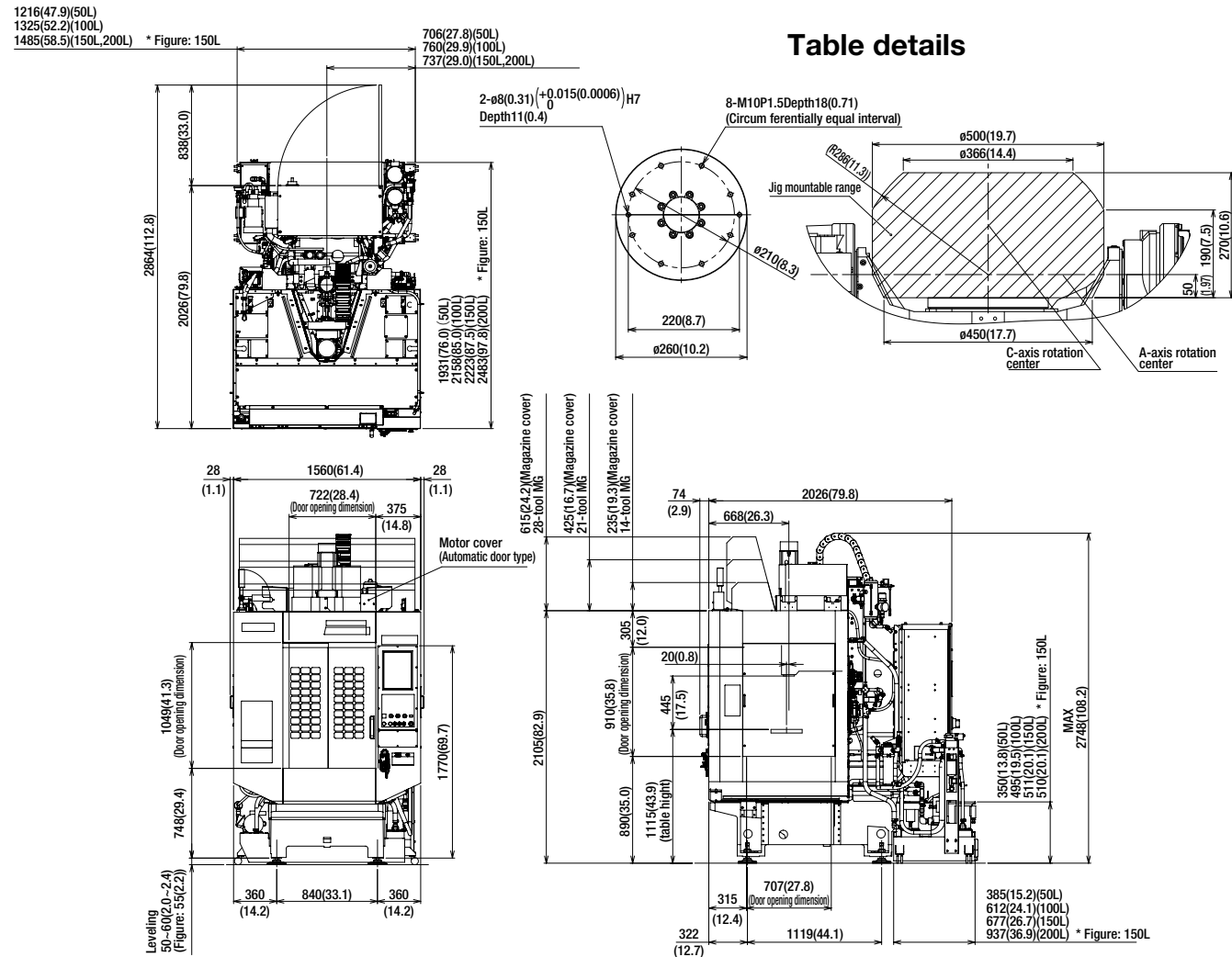

Machine specifications

Item	U500Xd1 / U500Xd1 RD *8	
CNC Unit	CNC-D00	
Travels	X axis	500 (19.7)
	Y axis	400 (15.7)
	Z axis	300 (11.8)
	A axis	120~-30
	C axis	360
Table	Distance between table top and spindle nose end	145~445 (5.7~17.5)
	Work area size	ø260 (ø10.2)
	Max. loading capacity(uniform load)	100 (220)
Spindle	Max. table load inertia	1.8 (6151) [2.6 (8885) *9]
	Spindle speed	10,000min ⁻¹ specifications: 1~10,000 16,000min ⁻¹ specifications (Optional): 1~16,000
Feed rate	Speed during tapping	MAX. 6,000
	Tapered hole	7/24 tapered No.30
	BT dual contact spindle (BIG-PLUS)	Optional
ATC unit	Coolant Through Spindle (CTS)	Optional
	Rapid traverse rate (XYZ-area)	50 x 50 x 56 (1,969 x 1,969 x 2,205)
Tool change time *5	Cutting feed rate	X, Y, Z axis: 1~30,000 (0.04~1,181) *7
	Indexing feedrate (A and C)	A axis: 50 C axis: 75 (60) *9
Electric motor	Tool shank type	MAS-BT30
	Pull stud type *4	MAS-P30T-2
Power source	Tool storage capacity	pcs. 14/21/28
	Max. tool length	mm(inch) 250 (9.8)
Machining dimensions	Max. tool diameter	mm(inch) 110 (4.3)
	Max. tool weight *1	kg(lbs) 3.0 (6.6) [4.0 (8.8) *10] / tool, <TOTAL TOOL WEIGHT: 25 (55.1) for 14 tools, 35 (77.2) for 21 or 28 tools>
Accuracy *3	Tool selection method	Random shortcut method
	Tool To Tool	0.6 / 0.7 (14 or 21 tools / 28 tools)
Standard accessories	Chip To Chip	1.2 / 1.3 (14 or 21 tools / 28 tools)
	Main spindle motor (10min/continuous) *2	10,000min ⁻¹ specifications: 10.1/7.0, 16,000min ⁻¹ specifications (optional): 7.4/5.1
Power supply	Axis feed motor	X,Y axis: 1.0 Z axis: 2.0 A axis: 0.9 C axis: 0.55
	Power capacity(continuous)	kVA AC 200 to 230 V±10%, 3-phase, 50/60Hz±2%
Machining dimensions	Air supply Regular air pressure	MPa 10,000min ⁻¹ specifications: 9.5, 16,000min ⁻¹ specifications (optional): 9.5
	Air supply Required flow	L/min 0.4~0.6 (recommended value 0.5MPa) *6
Machining dimensions	Height	mm(inch) 2,748 (108.2)
	Required floor space *11 [with control unit door open]	mm(inch) 1,560 x 2,026 [2,864] (61.4 x 79.8 [112.8])
Accuracy *3	Weight	kg(lbs) 2,650 (5,843)
	Accuracy of bidirectional axis positioning (ISO230-2:1988)	X, Y, Z axis: 0.006~0.020mm (0.00024~0.00079 inch)
Accuracy *3	Accuracy of bidirectional axis positioning (ISO230-2:2014)	A, C axis: 28 sec or less
	Repeatability of bidirectional axis positioning (ISO230-2:2014)	X, Y, Z axis: Less than 0.004mm (0.00016 inch) A, C axis: 16 sec or less

Tool Dimensions

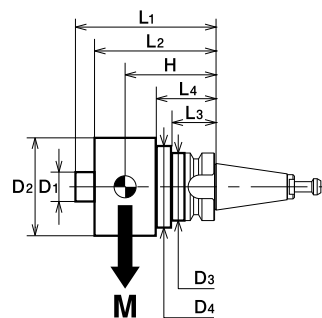

Maximum Spindle Speed	10000min ⁻¹ / 16000min ⁻¹		
Spindle Taper	7 / 24 No.30		
Tool Shank	MAS-BT		
Pull Stud	MAS-P30T-2		
Total for All Magazine Tools	M total 25kg (14 Tools) / 35kg (21/28 Tools)		
Maximum tool specification settings	Heavy tool	Standard tool	
	D1 ≤ 40mm L1 ≤ 250mm D2 ≤ 110mm L2 ≤ 160mm D3 ≤ 46mm L3 ≤ 30mm D4 ≤ 80mm L4 ≤ 35mm M ≤ 4kg MxH ≤ 360kg-mm	D1 ≤ 40mm L1 ≤ 250mm D2 ≤ 110mm L2 ≤ 160mm D3 ≤ 46mm L3 ≤ 30mm D4 ≤ 80mm L4 ≤ 35mm M ≤ 3kg MxH ≤ 180kg-mm	D1 ≤ 40mm L1 ≤ 250mm D2 ≤ 55mm L2 ≤ 160mm D3 ≤ 46mm L3 ≤ 30mm M ≤ 2kg MxH ≤ 100kg-mm
Tool Balance Limit	60g-mm	100g-mm	50g-mm
Tool Speed Limit	10000min ⁻¹		16000min ⁻¹

NC unit specifications

CNC model	CNC-D00	
Control axes	5 axes (X, Y, Z, A, C)	
Simultaneously controlled axes	Positioning	5 axes (X, Y, Z, A, C)
	Interpolation	Linear: 4 axes (X, Y, Z, one additional axis) Circular: 2 axes Helical/Conical: 3 axes (X, Y, Z)
Least input increment	0.001 mm, 0.0001 inch, 0.001 deg.	
Max. programmable dimension	±999999.999 mm, ±99999.9999 inch	
Display	15-inch color LCD touch display	

Memory capacity	500 Mbytes, 3 Gbytes (optional) (Total capacity of program and data bank)
External communication	USB memory interface, Ethernet, RS232C (optional)
No. of registrable programs	4,000 (Total capacity of program and data bank)
Program format	NC language, conversation (changed by parameter) Conversion from conversation program to NC language program available

* "Control axes" and "Simultaneously controlled axes" indicate the maximum number of axes, which will differ depending on the destination country and the machine specifications.
* Ethernet is a registered trademark of Xerox Corporation in the United States.

NC functions

Operation	Dry run	Monitoring	Machining load monitoring	Energy saving	Automatic power off	Functions limited to NC language	Menu programming
	Machine lock		ATC tool monitoring		Standby mode		Local coordinate system
Programming	Program restart	Maintenance	Overload prediction	Support apps	Automatic coolant off	Accessories	Expanded workpiece coordinate system
	Rapid traverse override		Waveform display / Waveform output to memory card		Automatic work light off		One-way positioning
	Cutting feed override		Heat expansion compensation system II (X, Y, and Z axes)		Chip shower off delay		Inverse time feed
	Background editing		Production performance display		Adjust machine parameters		Programmable data input
	Screen shot		Tool life / Spare tool		ATC tool		Tool length compensation
	Operation level		Tap return function		Tool life		Cutter compensation
	External input signal key		Status log		Waveform display		Scaling
	Shortcut keys		Alarm log		Production performance		Mirror image
	<Optional>		Operation log		Power consumption		External sub program call
	Spindle override		Maintenance notice		Recovery support		Macro
Measurement	Absolute / Incremental	Automatic / Network	Motor insulation resistance measurement	File viewer	Notebook	Submicron command *2	Operation in tape mode
	Inch / Metric		Tool washing filter with filter clogging detection				Calculator
High speed and high accuracy	Coordinate system setting	High accuracy mode A/II	Battery-free encoder	Register shortcut	Display off	Involute interpolation	Multiple skip function
	Corner C / Corner R		Rotational transformation				OPC UA
High accuracy mode BII	Synchronized tap	High-accuracy mode BI (look-ahead 160 blocks)	Brake load test	Interrupt type macro	Register shortcut	Rotary fixture offset	Feature coordinates setting
	Subprogram		Graphic display				Built-in PLC (LD/ST/FBD)
High accuracy mode BII	Subprogram	High-accuracy mode BII (Look-ahead 1,000 blocks, smooth path offset)	<Optional>	Display off	Display off	Involute interpolation	Operation program
	Graphic display		CC-Link, master station				Schedule program
High accuracy mode BII	High accuracy mode BII	High-accuracy mode BII (Look-ahead 160 blocks)	CC-Link, remote device station	Display off	Display off	Involute interpolation	Automatic tool selection
	High accuracy mode BII		PROFIBUS-DP, slave				Automatic cutting condition setting
High accuracy mode BII	Backlash compensation	High-accuracy mode BII (Look-ahead 160 blocks)	DeviceNet, slave	Display off	Display off	Involute interpolation	Automatic tool length compensation setting
	<Optional>		PROFINET, slave				Automatic cutter compensation setting
High accuracy mode BII	High accuracy mode BII	High-accuracy mode BII (Look-ahead 1,000 blocks, smooth path offset)	EtherNet/IP, slave	Display off	Display off	Involute interpolation	Automatic calculation of unknown number input
	High accuracy mode BII		EtherNet/IP, slave				Machining order control

*1. Measuring instrument needs to be prepared by users.
*2. When the submicron command is used, changing to the conversation program is disabled.

Brother Technology Center Chicago

BROTHER INTERNATIONAL CORP.
2200 North Stonington Avenue, Suite 270, Hoffman Estates, IL 60169, U.S.A.
PHONE:(1)224-653-8415 FAX:(1)224-653-8821

Brother Technology Center Frankfurt

BROTHER INTERNATIONALE INDUSTRIEMASCHINEN GmbH
Hoechster Str.94, 65835 Liederbach, Germany
PHONE:(49)69-977-6708-0 FAX:(49)69-977-6708-80

Brother Technology Center Bengaluru

BROTHER MACHINERY INDIA PVT LTD.
SB-111-112, 1st Stage, 2nd Cross, Peenya Indl Estate, Bengaluru - 560058 Karnataka, India
PHONE:(91)80-43721645

Brother Technology Center Shanghai

BROTHER MACHINERY (SHANGHAI) LTD.
Unit 01, 5/F., No.799, West Tianshan Rd., ChangNing District Shanghai 200335, China
PHONE:(86)21-2225-6666 FAX:(86)21-2225-6688

Brother Technology Center Chongqing

BROTHER MACHINERY (SHANGHAI) LTD.
Room 30, 31, NO.104 Cui bai Road, Dadukou District, Chongqing Province, 400084, China
PHONE:(86)23-6865-5600 FAX:(86)23-6865-5560

Nanjing Office

BROTHER MACHINERY (SHANGHAI) LTD.
503 Room, Building No.1, No.39, Dongcun Road, Jiangning District, Nanjing City, Jiangsu Province, China
PHONE:(86)25-87185503

Brother Technology Center Queretaro

BROTHER INTERNATIONAL DE MÉXICO, S.A. DE C.V.
Calle 1 No.310 Int 15, Zona Industrial Jurica, Parque Industrial Jurica,
Queretaro, QRO C.P. 76100 México
PHONE:(52)55-8503-8760 FAX:(52)442-483-2667

Brother Technology Center Bangkok

BROTHER COMMERCIAL (THAILAND) LTD.
317 Pattanakarn Road, Pravet Sub-District, Pravet District, Bangkok 10250, Thailand
PHONE:(66)2321-5910 FAX:(66)2321-5913

Gurugram Service Center

BROTHER MACHINERY INDIA PVT LTD.
CE SERVICED OFFICES PVT. LTD., DLF CYBER HUB, Building No 10, Tower A, Level 1,
Phase 3, DLF Cyber City, Gurugram - 122002 Haryana - India
PHONE:(91)80-43721645

Brother Technology Center Dongguan

BROTHER MACHINERY (SHANGHAI) LTD.
Room 103, Building 1, No.2 Nanbo Road,
Songshan Lake District, Dongguan City, Guangdong Province, China
PHONE:(86)769-2238-1505 FAX:(86)769-2238-1506

Brother Technology Center Ningbo

BROTHER MACHINERY (SHANGHAI) LTD.
1F, Building 1, No. 102, Hongtang South Road West Section, Jiangbei District, Ningbo City,
Zhejiang Province, China
PHONE:(86)574-87781232 FAX:(86)574-88139792

Figures in brackets () are the country codes.

Specifications may be subject to change without any notice.

BROTHER INDUSTRIES, LTD.

Machinery Business Division

1-5, Kitajizoyama, Noda-cho, Kariya-shi, Aichi-ken 448-0803, Japan
<https://www.brother.co.jp>

