

## Global Service Sites

Local dealers are available to provide services in each region, in addition to the sites below.

### Brother Technology Center Chicago

**BROTHER INTERNATIONAL CORP.**  
2200 North Stonington Avenue, Suite 270, Hoffman Estates, IL 60169, U.S.A.  
PHONE:(1)224-653-8415 FAX:(1)224-653-8821

### Brother Technology Center Frankfurt

**BROTHER INTERNATIONALE INDUSTRIEMASCHINEN GmbH**  
Hochster Str.94, 65835 Liederbach, Germany  
PHONE:(49)69-977-6708-0 FAX:(49)69-977-6708-80

### Brother Technology Center Bengaluru

**BROTHER INTERNATIONAL (INDIA) PVT LTD.**  
SB-111-112, 1st Stage, 2nd Cross, Peenya Indl Estate, Bengaluru - 560058 Karnataka, India  
PHONE:(91)80-43721645

### Brother Technology Center Shanghai

**BROTHER MACHINERY (SHANGHAI) LTD.**  
Unit 01, 5/F., No.799, West Tianshan Rd., ChangNing District Shanghai 200335, P.R.China  
PHONE:(86)21-2225-6666 FAX:(86)21-2225-6688

### Brother Technology Center Chongqing

**BROTHER MACHINERY (SHANGHAI) LTD.**  
Room 30, 31, NO.104 Cuibai Road, Dadukou District, Chongqing Province, 400084, P.R.China  
PHONE:(86)23-6865-5600 FAX:(86)23-6865-5560

### Nangjing Office

**BROTHER MACHINERY (SHANGHAI) LTD.**  
503 Room, Building No.1, No.39, Dongcun Road, Jiangning District, Nangjing City, Jiangsu Province, P.R.China  
PHONE:(86)25-87185503

### Brother Technology Center Queretaro

**BROTHER INTERNATIONAL DE MÉXICO, S.A. DE C.V.**  
Calle 1 No.310 Int 15, Zona Industrial Jurica, Parque Industrial Jurica,  
Queretaro, QRO C.P. 76100 México  
PHONE:(52)55-8503-8760 FAX:(52)442-483-2667

### Brother Technology Center Bangkok

**BROTHER COMMERCIAL (THAILAND) LTD.**  
317 Pattanakarn Road, Pravet Sub-District, Pravet District, Bangkok 10250, Thailand  
PHONE:(66)2321-5910 FAX:(66)2321-5913

### Gurugram Service Center

**BROTHER INTERNATIONAL (INDIA) PVT LTD.**  
CE SERVICED OFFICES PVT. LTD., DLF CYBER HUB, Building No 10, Tower A, Level 1,  
Phase 3,DLF Cyber City,Gurugram - 122002 Haryana - India  
PHONE:(91)80-43721645

### Brother Technology Center Dongguan

**BROTHER MACHINERY (SHANGHAI) LTD.**  
1F, Fuyuan Business Center Building, No.5 Lane 13, Maiyuan Road, Xin'an community,  
Chang'an Town, Dongguan City, Guangdong Province, 523008, P.R.China  
PHONE:(86)769-2238-1505 FAX:(86)769-2238-1506

### Ningbo Office

**BROTHER MACHINERY (SHANGHAI) LTD.**  
1005-2 Room, Block C, Hebang building, No 899, Tiantong north road, Ningbo City,  
Zhejiang Province, P.R.China  
PHONE:(86)574-88139798 FAX:(86)57-88139792

Figures in brackets ( ) are the country codes.

- Please read the instruction manuals and safety manuals before using Brother products for your own safety.  
When using oil-based coolant oil or when machining the materials which can cause a fire (ex. Magnesium, resin material), customers are requested to take thoroughgoing safety measures against fire.  
Depending on the types of cutting material, cutting tools, coolant oil, lubrication oil, it may have an influence on the machine lifecycle.  
Further questions, please contact our sales representative in charge.
- Leave 700 mm between machines as a maintenance space.
- When exporting our machine, the machine is deemed to be included in the "applicable listed items" controlled by the Foreign Exchange and Foreign Trade Law of Japan. When exporting the machine, please obtain required permissions, including an export license, from the Ministry of Economy, Trade and Industry (METI) or Regional Bureaus of Economy, Trade and Industry before shipment. When re-selling or re-exporting the machine, you may need to obtain permissions from METI, and the government of the country where the machine is installed.
- When exporting our machine, as a machine conforming to Row 2 of Appended Table 1 of Export Trade Control Order, a relocation detection device is installed on the machine depending on the destination country. After relocating the machine with the detection device, the machine is locked and any operation is temporarily impossible. Please inform your local distributor of machine relocation in advance and apply to perform the release operation of relocated machine.

Specifications may be subject to change without any notice.

**brother**

**BROTHER INDUSTRIES, LTD.**

Machinery Business Division

1-5, Kitajizoyama, Noda-cho, Kariya-shi,  
Aichi-ken 448-0803, Japan  
PHONE: 81-566-95-0075  
FAX : 81-566-25-3721

<https://www.brother.com>

**SPEEDIO**

**brother**  
at your side

**Multi-Tasking Machine**

**M200X3**  
**M300X3**



## *Evolving Process Integration Machine*

Brother's competitive high-productivity technologies are fused with process integrated machining where both turning and milling are performed on one machine, achieving great improvement in production efficiency when machining mass production parts.

Two new models have been added that can handle larger workpieces and with an option to install a manpower reduction unit, to become a Series that can handle a variety of machining.



**SPEEDIO**  
**M300X3**

**SPEEDIO**



**SPEEDIO**  
**M200X3**

### **SPEC**

<b>Basic specifications</b>	
Max. spindle speed (min <sup>-1</sup> )	10,000 / 16,000 (Optional)
Max. turning spindle speed (min <sup>-1</sup> )	M300X3 : 1,500 M200X3 : 2,000
Travels (X, Y, Z) (mm)	M300X3 : X 300 Y 440 Z 305 M200X3 : X 200 Y 440 Z 305
Travels (A, C) (deg.)	A 120~-30、 C 360
Tool storage capacity (pcs.)	22
Rapid traverse rate (X, Y, Z) (m/min)	X 50 Y 50 Z 50
Indexing feedrate (A, C) (min <sup>-1</sup> )	M300X3 : A50 C200 M200X3 : A60 C200
Required floor space (mm)	M300X3 : 1,520 × 3,862 M200X3 : 1,280 × 3,862
Coolant Through Spindle (CTS)	Optional
BT dual contact spindle (BIG-PLUS)	Optional

### Features and effects

#### Process integration in one machine

Workpieces previously machined using a turning center and a machining center can now be machined on a single machine with machining processes integrated. This reduces handling time between machines.

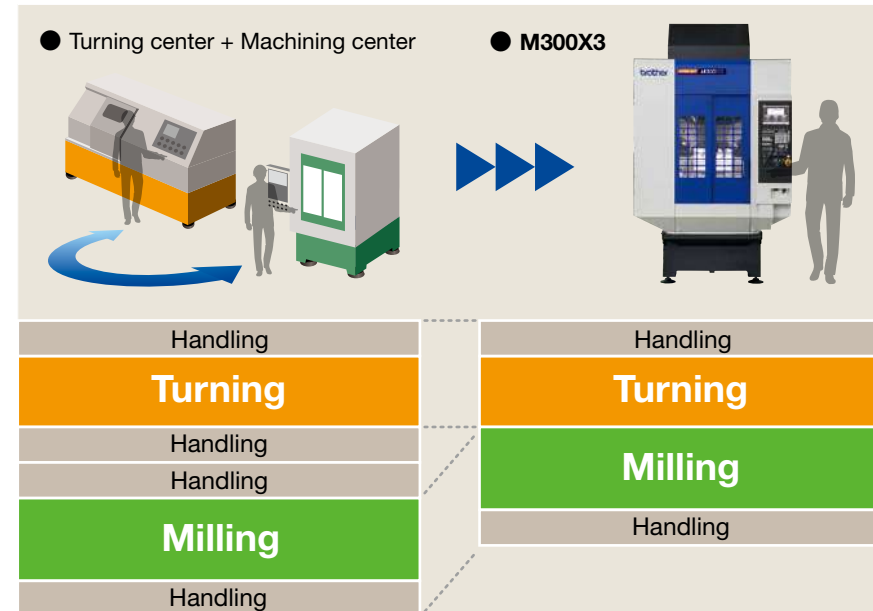

#### Example of process integration

Turning and multi-face milling are performed on one M200X3 (automotive parts).



Turning location    Milling location

### Workpiece reattachment not necessary between turning center and machining center



### Target machining parts

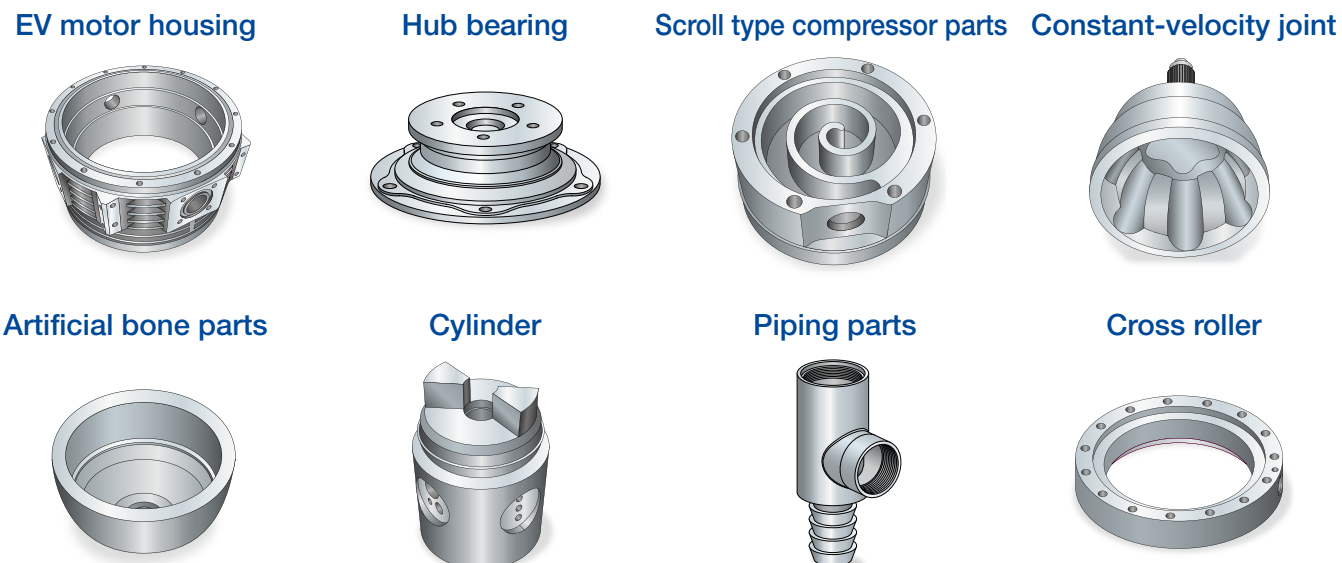

### Machine structure

The machine has an original design, including the magazine structure, that keeps the machine compact while maintaining the rigidity of each axis and the balance of rigidity.

#### Tilt axis (A-axis)

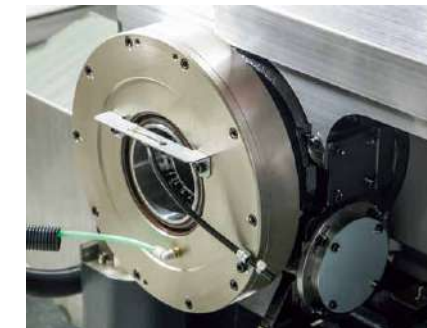

A roller gear cam is used for the tilt axis (A-axis). High retention force and a backlashless structure achieve high-speed and high-accuracy indexing.

#### Turning spindle (C-axis)

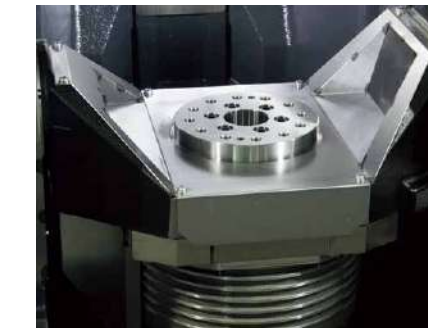

A high-speed and high-output built-in DD motor is used for the turning spindle (C-axis). This achieves efficient turning and high-speed indexing.

#### Double plunger lock



An original double plunger lock is used to secure turning tools, achieving excellent tool change repeatability.

### Expansion of machining area

Wide machining area has been secured to allow more flexibility for jig design to meet a variety of workpiece machining.

- The distance between the table top surface and the spindle nose end has been increased to secure sufficient area for the jig, workpiece and tool in the Z-axis direction.
- Distance between table top surface and spindle nose end  
M300X3: 505mm    M200X3: 455mm

Max. jig size  
M300X3:  $\phi 350\text{mm} \times \text{H}350\text{mm}$   
M200X3:  $\phi 300\text{mm} \times \text{H}300\text{mm}$

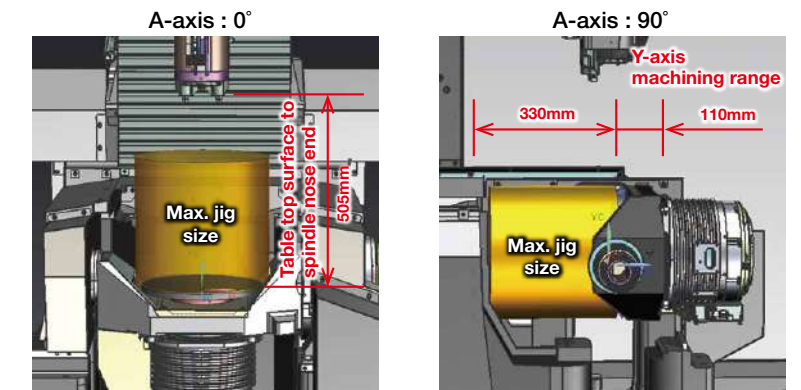

\*There is a contact area around the table top surface. Please refer to the table details.

### Example of jig configuration

Applicable to a variety of jigs from manual clamping to automatic clamping

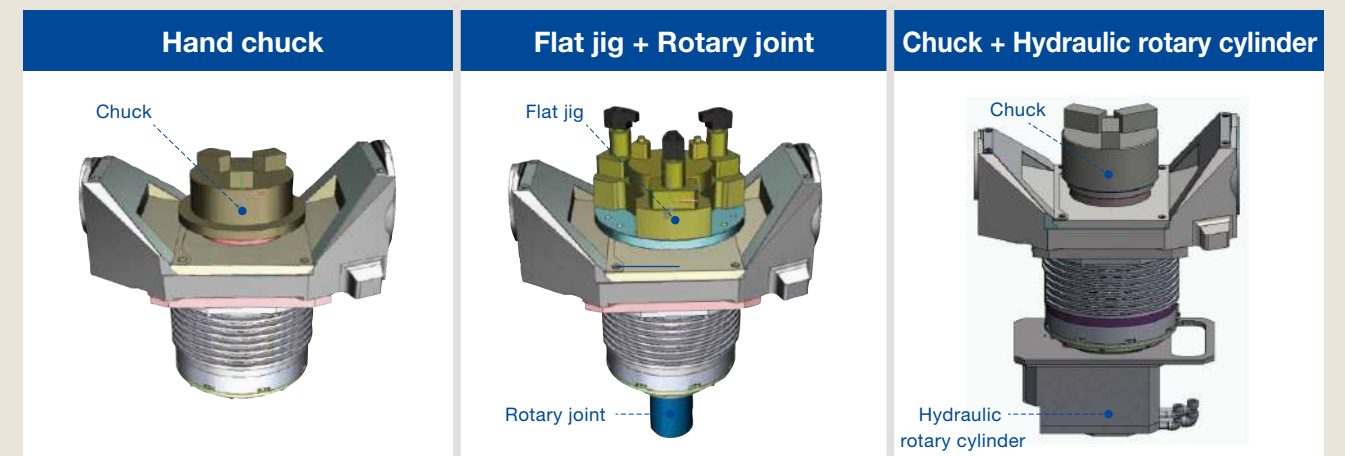

\*General or special options are included in figures. Please contact your local distributor for chucks that can be mounted.

### Productivity

#### Fast acceleration/deceleration spindle

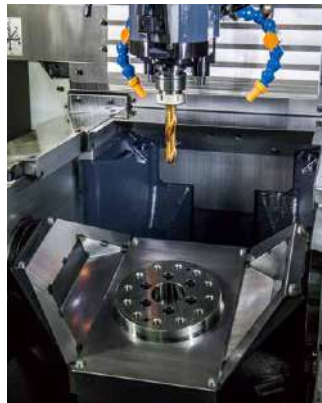

Using a fast acceleration / deceleration spindle motor and highly-responsive servo control achieves quicker starting and stopping of the spindle and turning spindle.

**Start / stop time**  
**Spindle : 0.2s**  
**Turning spindle : 0.3s**

#### High-speed tool change



Using a compact 22-tool magazine with excellent weight balance and optimal control achieves high-speed tool change, with any wasted operation eliminated.

**M200X3**  
**Chip-Chip : 1.4s**  
**Tool-Tool : 0.8s**

#### High-speed synchronized tapping

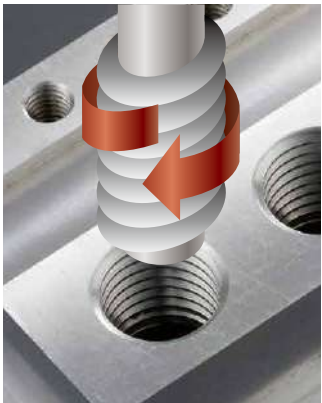

Original synchronized tapping control enables high-accuracy tapping at the fastest level in the world.

**Peripheral speed:**  
**377m/min**

\* M20, spindle speed 6,000 min<sup>-1</sup>

#### Simultaneous operation

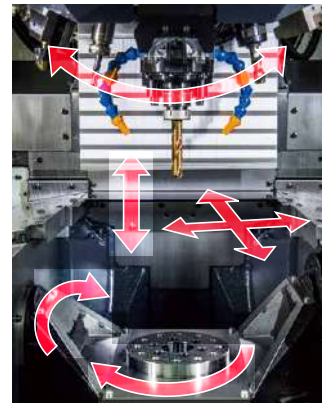

Wasted time is further reduced by positioning the X/Y/Z axes and A/C axes simultaneously with tool changes.

**Reduction in non-cutting time**

#### Loading system for manpower reduction (M200X3)

Simple, compact, and easy installation/startup

#### Specialized for loading/unloading workpieces

4-axis articulated arm for easy handling

#### Compactly installed on the side of machine

The loading system is integrated with the machine, requiring less installation space.

#### Controller incorporated in machine's control box

Wiring connection with NC is not necessary, and signal lines are connected. Piping, wiring, and valves for the hand are stored in the body, and the side door is standard equipped.

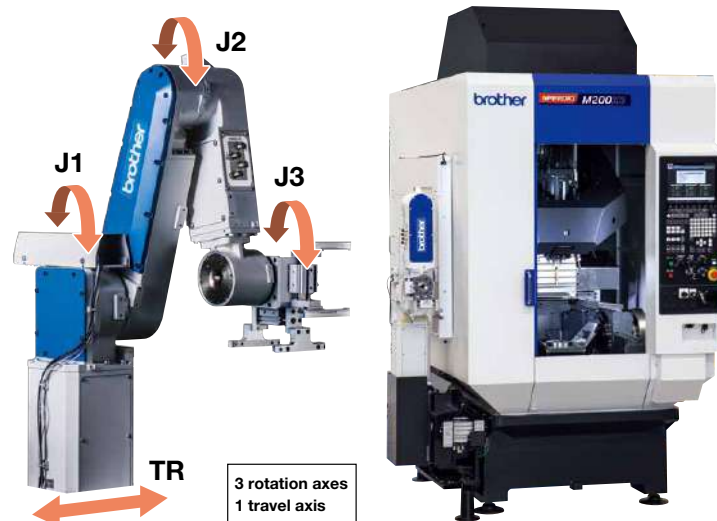

### Milling capabilities

As the spindle can provide high torque even in the medium- and high-speed range, the machine fully demonstrates its capabilities in high-speed, high-efficiency machining of aluminum or steel.

**Max. torque : 40Nm Max. output : 18.9kW**



		Drilling			Tapping			Facing		
		ADC	FC250	S45C	ADC	FC250	S45C	ADC	FC250	S45C
<b>M300X3</b>	10,000min <sup>-1</sup>	D28×0.2 (1.1 × 0.008)	D28×0.15 (1.1 × 0.006)	D23×0.1 (0.9 × 0.004)	M22×2.5 (7/8-9UNC)	M22×2.5 (7/8-9UNC)	M16×2.0 (5/8-11UNC)	611 (37.3)	110 (6.7)	54 (3.3)
<b>M200X3</b>	10,000min <sup>-1</sup>	D28×0.2 (1.1 × 0.008)	D28×0.15 (1.1 × 0.006)	D23×0.1 (0.9 × 0.004)	M22×2.5 (7/8-9UNC)	M22×2.5 (7/8-9UNC)	M16×2.0 (5/8-11UNC)	489 (29.8)	110 (6.7)	54 (3.3)

\* The A axis is 0 degrees and X/Y-axes are at their travel center. The above performance may not be achieved under some conditions, depending on usage environment, tools in use and coolant.

### Turning capabilities

High-efficiency machining is achieved by the high-output turning spindle with a maximum speed of 2,000min<sup>-1</sup>(M200X3), and the turning tool secured by the double plunger lock.

**Max. torque**  
**M300X3: 102Nm**      **Max. output**  
**M300X3: 9.9kW**  
**M200X3: 55Nm**      **M200X3: 8.7kW**



### Improved clamp torque

#### C-axis clamp torque

The C-axis mechanical clamp torque has almost doubled (compared to previous model). This enables more stringent cutting conditions to be set for machining that results in load being applied in the C-axis rotation direction, improving production efficiency.

**C-axis clamp torque**  
**M300X3: 450Nm**  
**M200X3: 345Nm**

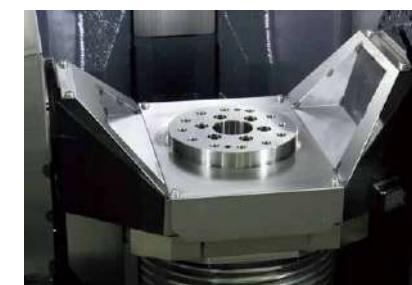

#### A-axis clamp (optional)

The mechanical clamp enables the machine to demonstrate high machining capabilities even in high-load machining. In addition, stable rotation and less vibration during lathe turning have been achieved, improving machining accuracy.

**A-axis clamp torque**  
**M300X3 / M200X3: 500Nm\***

\* Standard specifications  
 Holding torque (max./continuous): 400Nm/200Nm



A-axis clamp (M300X3)



Improves machining accuracy and capabilities when the A-axis is tilted or machining is performed in a full machining range.



Vibration caused by imbalance of the jig or workpiece during C-axis rotation has been minimized, achieving stable rotation to prevent the decrease in machining accuracy.

### Reliability

Chip discharge performance and handling capability have been improved along with the expansion of the machine area. In addition, the machine is equipped with functions to improve reliability, such as chip shower and air-assisted tool washing.

#### Center trough structure

Chip discharge performance has been improved by the tilted base and the center trough structure.



#### Tank with cyclone filter (special option for CTS)

Coolant is returned to a clean tank through a tank with a cyclone filter with fine chips removed. This reduces the filter change frequency and extends the service life of the pump.

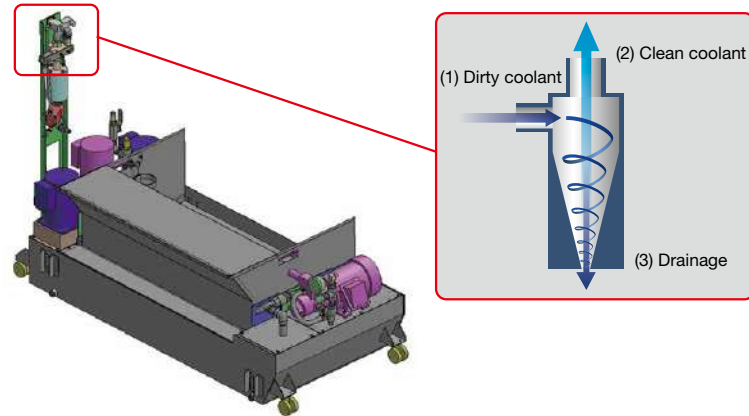

### Operability

The machine is equipped with our original "CNC-C00 Series" controller, created through machine/controller integrated development.



#### Equipped with tool monitoring functions

##### ATC monitoring

The presence of a spindle tool is detected without using a sensor.

##### Machining load monitoring function

The machining load applied to the spindle is monitored to detect an abnormality of the tool or machining.

##### Thread cutting function

Straight thread cutting and tapered-thread cutting are possible.



##### Control box size

Space has been increased for system expansion in case of automation etc.

#### USB interface

In addition to file input/output, various data in the CNC, including waveform data, can be output.

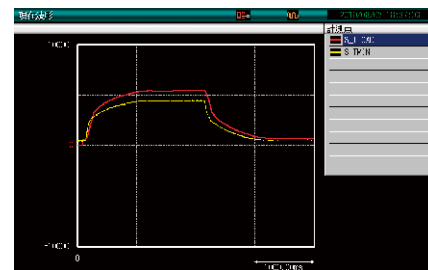

#### PLC function

Standard equipped with PLC. Input and output points can be expanded to up to 1,024 points each (optional).

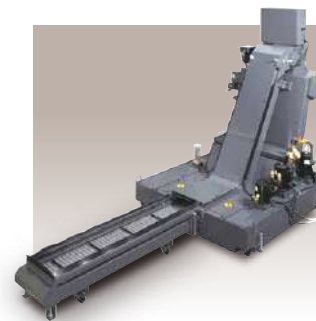
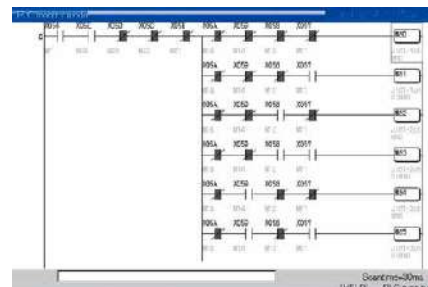

#### Chip conveyor tank

A two-step structure (hinged plate and scrapper) is used, enabling discharge of chips in a variety of sizes and shapes. An oil skimmer can be added.



#### Coolant tank with chute

Coolant flows through the chute to discharge chips. The chute can be separated from the coolant tank, making maintenance easier. \*1



#### Chip shower

Chip shower pipes are located at the upper section inside the machine for more efficient flow, and flexible shower nozzles can be directed to the side of the machine cover or sections where chips tend to accumulate.



#### Coolant Through Spindle (CTS)

1.5 MPa CTS used for BT spindle. \*Please consult your local distributor for use of 3 MPa CTS.



#### Manual pulse generator

A cable is provided for the manual pulse generator, making setup easier.



#### Automatic door with switch panel 10 holes

A motor-driven door is used, achieving smooth operation and reducing opening/closing time.



#### Side cover with transparent window

External light is drawn in to make the inside of the machine brighter and improve visibility.



#### Side door with transparent window

This makes setup from the side easier. It is possible to check the machining room through the transparent window and operate the manual pulse generator through the side door.



#### Automatic oil lubricator / Automatic grease lubricator

Regularly applies oil or grease to all lubricating points on the three axes. \*Manual greasing is required for the standard specification model.



#### Tool breakage detector, touch type

A touch switch type tool breakage detector is used.

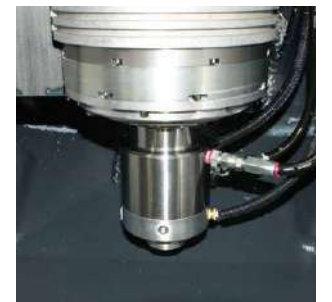

#### Rotary joint 4P

A rotary joint with four ports (two hydraulic, one pneumatic, and one common for hydraulic, coolant, and pneumatic) has been prepared, which is attached to the bottom of the turning spindle motor. \*2

\*1 Chips may not be discharged correctly depending on the shape of chips. When you select the coolant tank with chute, you must also select the chip shower. Please contact your local distributor for details.

\*2 The rotary joint must be used with hydraulic oil supplied. If hydraulic oil is not supplied, only conduct indexing operation or remove the rotary joint from the turning spindle motor.

\*Depending on the type of coolant, it may have a significant influence on the machine lifecycle. It is recommended to use the coolant which is commercially designated as high lubricity, for example Emulsion type.

\*Especially, the coolant of chemical solution type (ex. Synthetic type) is prohibited to use, because it may cause machine damages.

\*When using CTS (Coolant Through Spindle) function, usage of the coolant of combustible type (ex. Oil-based type) is prohibited.

#### Optional Specifications

- |   |  |   |  |  |
|---|--|---|--|--|
| <ul style="list-style-type: none"> <li>● Coolant tank                     <ul style="list-style-type: none"> <li>① Two-step chip conveyor tank, 370L</li> <li>② Two-step chip conveyor tank, 370L for CTS 1.5MPa with cyclone filter</li> <li>③ Coolant tank, 150L with chute</li> <li>④ Coolant tank, 150L for CTS 1.5MPa with chute and cyclone filter</li> </ul> </li> <li>● Coolant Through Spindle (CTS) 1.5MPa</li> </ul> | <ul style="list-style-type: none"> <li>● Mesh basket for collecting chips</li> <li>● Head coolant nozzle</li> <li>● Tool washing, air-assisted type</li> <li>● Rotary joint 4P</li> <li>● Tool breakage detector, touch type</li> <li>● Chip shower</li> <li>● Cleaning gun</li> <li>● Fixture shower valve unit</li> <li>● A-axis clamp</li> <li>● Automatic oil lubricator</li> <li>● Automatic grease lubricator</li> <li>● Work light, 1 or 2 lamps</li> </ul> | <ul style="list-style-type: none"> <li>● Signal light, 1, 2, or 3 lamps</li> <li>● Area sensor</li> <li>● Automatic door with switch panel 10 holes</li> <li>● Specified color</li> <li>● Manual pulse generator</li> <li>● Spindle override</li> <li>● Grip cover for tool magazine</li> <li>● Side cover with transparent window (single side, both sides)</li> <li>● Side door with transparent window right side</li> </ul> | <ul style="list-style-type: none"> <li>● Switch panel 8 or 10 holes</li> <li>● RS232C 25pin connector at control box</li> <li>● Master on circuit</li> <li>● 100V outlet in control box</li> <li>● Power supply expansion 50A</li> <li>● Breaker handle cover</li> <li>● Memory expansion 500 Mbytes</li> <li>● EXIO board assembly                     <ul style="list-style-type: none"> <li>① EXIO board, input32/output32, additional #1</li> <li>② EXIO board, input32/output32, additional #2</li> </ul> </li> </ul> | <ul style="list-style-type: none"> <li>● Fieldbus                     <ul style="list-style-type: none"> <li>① CC-Link, master station</li> <li>② CC-link, remote device station</li> <li>③ PROFIBUS DP, slave</li> <li>④ DeviceNet, slave</li> </ul> </li> <li>● PLC programming software for Windows® Vista, 7, and 8.1</li> </ul> |
|---|--|---|--|--|

\* Windows® is a trademark or registered trademark of Microsoft Corporation in the United States and/or other countries. \*Please contact your Brother dealer for details.

### Outline drawing

#### ●M300X3 (Chip conveyor type)

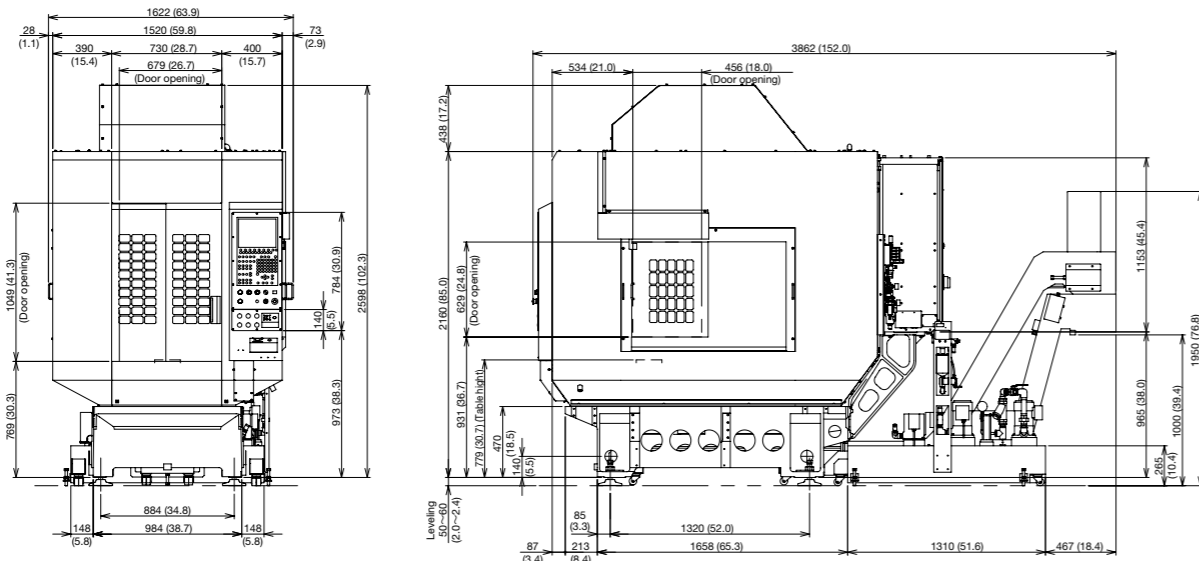

#### ●M200X3 (Chute type)

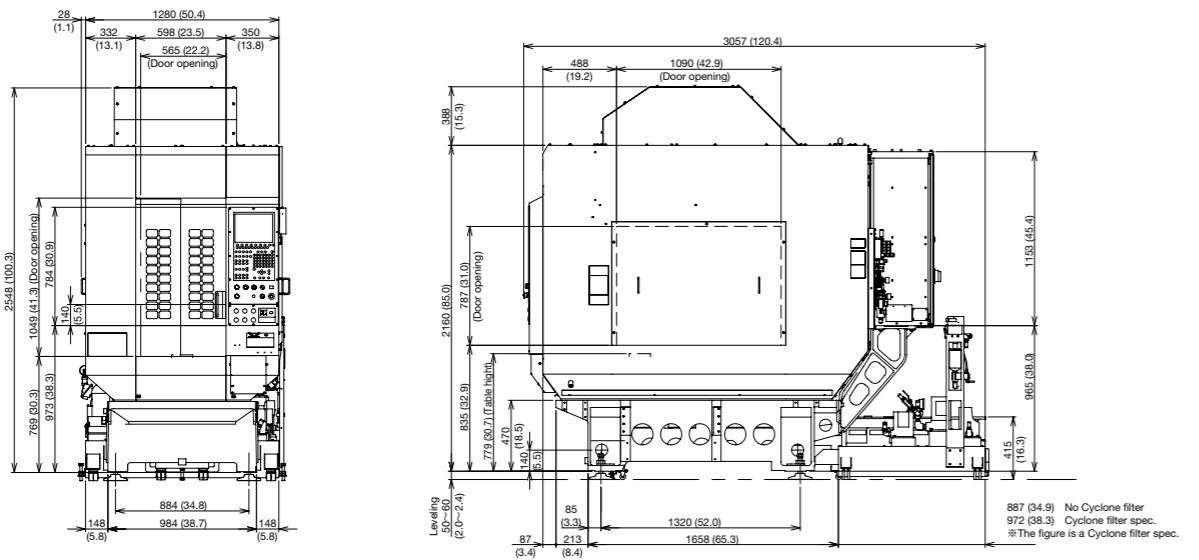

Secure 700 mm (27.6 inch) between machines as maintenance space.

### Table details

#### ●M300X3

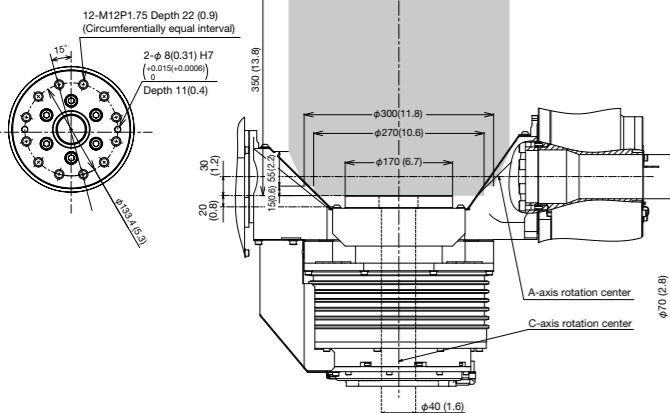

#### ●M200X3

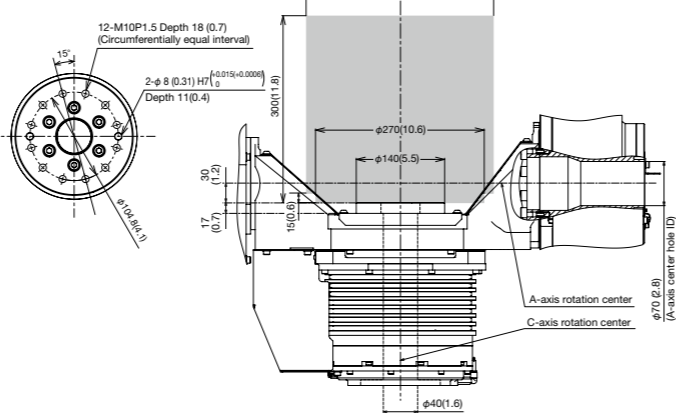

mm (inch)

Item	M300X3 / M300X3 RD *8	M200X3 / M200X3 RD *8
CNC Unit	CNC-C00	
X axis	300 (11.8) mm (inch)	200 (7.9)
Y axis	440 (17.3)	440 (17.3)
Z axis	305 (12.0)	305 (12.0)
A axis	120 ~ -30 (deg.)	120 ~ -30
C axis	360 (deg.)	360
Distance between table top and spindle nose end	200 ~ 505 (7.9 ~ 19.9) mm (inch)	150 ~ 455 (5.9 ~ 17.9)
Work area size	Φ170 (Φ6.7) mm (inch)	Φ140 (Φ5.5)
Table	In compliance with table nose No.5 of ISO702-4 (JISB6109-2)	
Max. loading capacity(uniform load)	Table side 75 (165.3) / Tale side 11 (24.3) kg (lbs)	Table side 40 (88.2) / Tale side 11 (24.3)
Max. table load inertia	Table side 0.58 (1982) / Tale side 0.04 (137) kg·m <sup>2</sup> (lb·inch <sup>2</sup> )	Table side 0.29 (991) / Tale side 0.04 (137)
Spindle speed	10,000min <sup>-1</sup> specifications : 1~10,000 16,000min <sup>-1</sup> specifications (Optional) : 1~16,000	
Speed during tapping	MAX. 6,000 min <sup>-1</sup>	
Tapered hole	7/24 tapered No.30	
BT dual contact spindle(BIG-PLUS)	Optional	
Coolant Through Spindle(CTS)	Optional	
Turning spindle	1,500 min <sup>-1</sup>	
Max. spindle speed	1,500 min <sup>-1</sup>	
Rapid traverse rate(XYZ-area)	50 x 50 x 50 (1,969 x 1,969 x 1,969) m/min(inch/min)	
Feed rate	X, Y, Z axis : 1 ~ 30,000 (0.04 ~ 1,181) *7 mm/min(inch/min)	
Cutting feed rate	X, Y, Z axis : 1 ~ 30,000 (0.04 ~ 1,181) *7 mm/min(inch/min)	
Indexing feedrate(A and C)	A axis : 50 C axis : 200 mm/min(inch/min) A axis : 60 C axis : 200	
Tool shank type	MAS-BT30	
Pull stad type *4	MAS-P30T-2	
Tool storage capacity	22 pcs.	
Max. tool length	200 (7.9) mm (inch)	
Max. tool diameter	80 (3.1) mm (inch)	
Max. tool weight *1	3 (6.6) kg (lbs)	
Tool selection method	Random shortcut method	
*5 Tool To Tool	0.8 sec.	
Chip To Chip	1.6 sec.	
Electric motor	10,000min <sup>-1</sup> specifications : 10.1/7.0 16,000min <sup>-1</sup> specifications (Optional) : 7.4/5.1 kW	
Axis feed motor	X,Y axis : 1.0 Z axis : 1.8 A axis : 1.35 kW	
Turning spindle motor	4.6 kW	
Power source	AC 200V±10%, 50/60Hz±1Hz	
Power capacity(continuous)	10,000min <sup>-1</sup> specifications : 9.5 16,000min <sup>-1</sup> specifications (Optional) : 9.5 kVA	
Regular air pressure	0.4~0.6 (recommended value : 0.5MPa) *6 MPa	
Required flow	165 L/min	
Machining dimensions	Height 2,653 (104.4) mm (inch) 2,603 (102.5)	
Required floor space	1,520 x 3,862 (59.8 x 152.0) mm (inch) 1,280 x 3,862 (50.4 x 152.0)	
Weight	2,880 (6,349) kg (lbs) 2,750 (6,063) [3,050 (6,724) with BV7-870]	
Accuracy *3	Accuracy of bidirectional axis positioning(ISO230-2:1988) mm (inch) X, Y, Z axis : 0.006~0.020 (0.00024~0.00079) A, C axis : 28 sec or less	
Repeatability of bidirectional axis positioning(ISO230-2:2014)	mm (inch) X, Y, Z axis : Less than 0.004 (0.00016) A, C axis : 16 sec or less	
Standard accessories	Instruction Manual (1 set), leveling bolts (4 pcs.), leveling plates (4 pcs.)	

\*1. The maximum tool weight differs depending on the configuration and center of gravity. The figures shown here are for reference only. \*2. Spindle motor output differs depending on the spindle speed. \*3. Measured in compliance with ISO standards and Brother standards. Please contact your local distributor for details. \*4. Brother specifications apply to the pull studs for CTS. \*5. Measured in compliance with JIS B6336-9 and MAS011-1987. \*6. Regular air pressure varies depending on the machine specifications, machining program details, or use of peripheral equipment. Set the pressure higher than the recommended value. \*7. When high accuracy mode B is used (When not used, 1 ~ 10,000 mm/min for X/Y axes and 1 ~ 20,000 mm/min for Z axis) \*8. The machine needs to be equipped with a relocation detection device depending on the destination. Machines equipped with a relocation detection device come with "RD" at the end of the model name.

NC unit specifications	
CNC model	CNC-C00
Control axes	5 axes (X,Y,Z,A,C)
Positioning	5 axes (X,Y,Z,A,C)
Interpolation	Linear: 4 axes (X, Y, Z, one additional axis) Circular: 2 axes Helical/conical: 3 axes (X,Y,Z)
Least input increment	0.001mm, 0.0001inch, 0.001 deg.
Max. programmable dimension	±9999.999mm, ±999.999inch
Display	12.1-inch color LCD
Memory capacity	Approx.100 Mbytes (Total capacity of program and data bank)
External communication	USB memory interface, Ethernet, RS232C 1ch
No. of registrable programs	4,000 (Total capacity of program and data bank)
Program format	NC language *Conversation language not available.

\*Ethernet is a trademark or registered trademark of XEROX in the United States.

Standard NC functions		
● Absolute / incremental	● Graphic display	● Screen shot
● Inch / metric	● Subprogram	● Auto notification
● Corner C / Corner R	● Helical / conical interpolation	● Inverse time feed
● Rotational transformation	● Tool washing filter with filter clogging detection	● Spindle load monitoring function
● Synchronized tap	● Automatic power off (energy saving function)	● ATC monitoring function
● Coordinate system setting	● Servomotor off standby mode (energy saving function)	● Expanded workpiece coordinate system
● Dry run	● Restart	● Scaling
● Backlash compensation	● Chip shower off delay	● Mirror image
● Rapid traverse override	● Automatic coolant off (energy saving function)	● Menu programming
● Cutting feed override	● Alarm history (1,000 pieces)	● Programmable data input
● Status log	● Machine lock	● Tool length compensation
● Computer remote	● Computer remote	● Cutter compensation
● Built-in PLC	● Motor insulation resistance measurement	● Macro function
● Operation log	● High accuracy mode AIII	● Local coordinate system
● High accuracy mode AIII	● Tool length measurement	● One-way positioning
● Tool life management / spare tool	● Tool life management / spare tool	● Heat expansion compensation systemII (X,Y,Z axes)
● Background editing	● Background editing	● Tap return function
		● Automatic workpiece measurement *1
		● Waveform display
		● Operation level
		● External input signal key
		● High accuracy mode BI(look-ahead 40 blocks)
		● Waveform output to memory card
		● Nose R compensation
		● Thread cutting function

Optional NC functions		
● Memory expansion 500 Mbytes	● High accuracy mode BII, look-ahead 200 blocks, with smooth path offset	● Feature coordinate setting function
● High-speed processing *2	● Rotary fixture offset	● Spindle override
● Involute interpolation	● Submicron command *3	● Interrupt type macro

\*1. Measuring instrument needs to be prepared by users. \*2. Minute block processing time can be changed. \*3. When the submicron command is used, changing to the conversation program is disabled.