



SIMULTANEOUS 5-AXIS VERTICAL  
MACHINING CENTER

# VC

**630/5AX** • **630/5AX with APC**



**DN SOLUTIONS**

# VC 630/5AX · 630/5AX with APC

---

The VC 630/5AX machining center provides full 5 axis simultaneous machining capability. It's highly rigid integral rotary/tilt table and high precision built in spindle provide the solution for both high speed and heavy duty machining of complex parts in one setting.





### HIGH-RIGIDITY MACHINE STRUCTURE

- The highly rigid structure designed by 3D simulation techniques, and responsive axis feed system provide world class precision machining capability.

### BUILT-IN SPINDLE

- The high performance built in spindle ensures optimum machining performance at high speed and heavy duty cutting.

### HIGHER MACHINING ACCURACY

- For higher accuracy, we provide the thermal displacement compensation system even during a prolonged period of machining and high-rigidity machine structure.

# BASIC STRUCTURE

High rigidity machine structure results in optimum static and dynamic rigidity verified by 3D simulation, resulting in highly stable precision machining.

## High-rigidity design and structure

Machine structure is designed by Finite Element Analysis Method (FEM) and the static/dynamic rigidity is further enhanced.

### Travel distance (X / Y / Z axis)

**650 / 765 / 520 mm**

25.6 / 30.1 / 20.5 inch

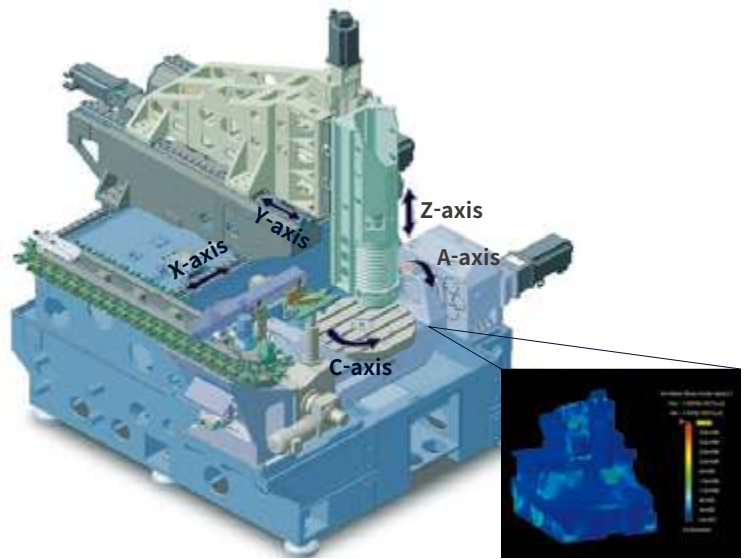

### Static rigidity

The static rigidity structure of the VC630/5AX has been increased by 30% through the FEM analysis.

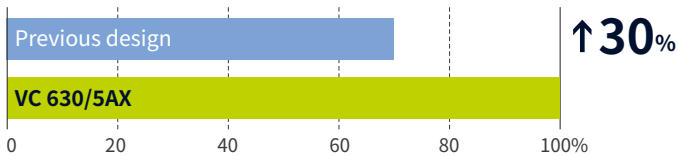

### Dynamic rigidity

FEM analysis was also used to improve the frequency response and vibration damping property by 35% over the previous design.

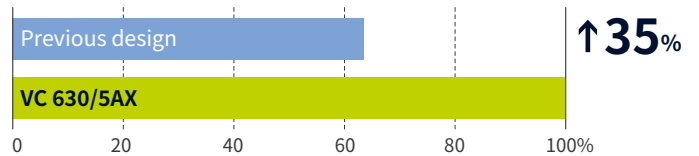

## High-rigidity axis feed system

The axis feed system structure is designed to achieve the combination of high rigidity and responsive feed motion. The base casting is made of heavy duty Meehanite Cast Iron which provides excellent vibration damping characteristics and guarantees highly stable machining conditions. Roller type linear guideways and highly rigid couplings are included to provide both rigidity and sensitive X, Y, Z axis feed. Ballscrew nut cooling reduces heat generation to minimise thermal displacement.

### Rapid travers (X / Y / Z axis)

**40 / 40 / 36 m/min**

1574.8 / 1574.8 / 1417.3 ipm

### Linear scale option

All axes are equipped with the linear scale as a optional feature to maintain the highest degree of accuracy over many hours of operation.



## High-rigidity roller type guideway



Rigidity and accuracy of feed system are improved with roller type guideway and coupling.



Roller type linear guideway

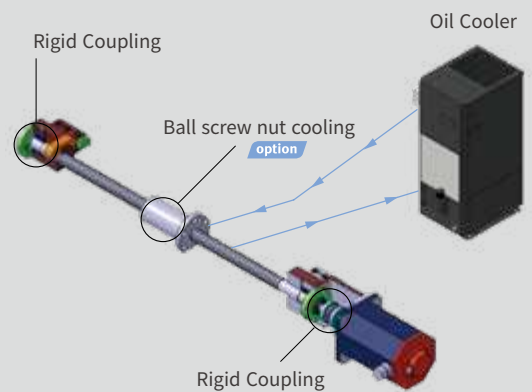

## Thermal error compensation

live data is collected from multiple temperature sensors around the machine are combined with DN Solutions feed system smoothing algorithms to provide real time thermal compensation and provide optimum precision.

### Heat displacement of VC630/5AX after compensation

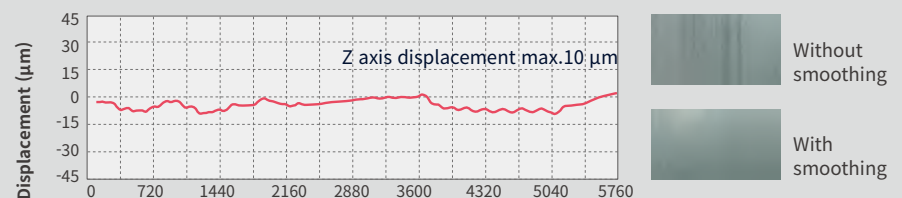

# SPINDLE

Built-in motor minimizes vibration and noise generated.

## Built-in spindle

The main spindle is optimally designed with 4 row precision ceramic bearing whose features, low centrifugal force and minimum heat generation, are great merits at high speed condition. The high productivity is realized by reduction of the acceleration time to the maximum speed of main spindle.

### Max. spindle speed

**12000** r/min

**20000** r/min option

**30000** r/min option

30000 r/min spindle selection for high productivity is available.

(Please consult with DN Solutions in advance for detailed specifications.)

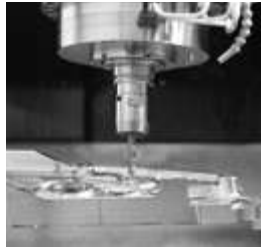

## Spindle motor

Spindle motor power output (30min/cont. : 12000 r/min)

FANUC

**22 / 18.5** kW 29.5/24.8 Hp

HEIDENHAIN

**30 / 24** kW 40.3/32.2 Hp

SIEMENS

**30 / 24** kW 40.3/32.2 Hp

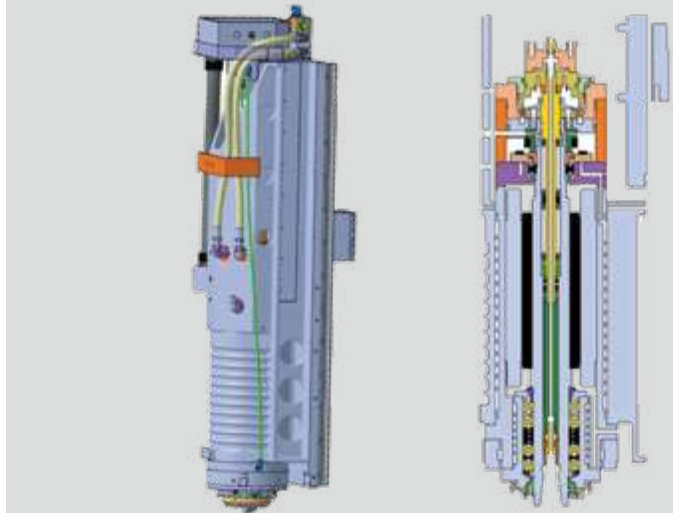

## Dual contact spindle

Dual contact spindle is adopted to improve spindle life and surface roughness in high-speed cutting process.

**Big Plus**  
(standard)

**HSK-A63**  
option

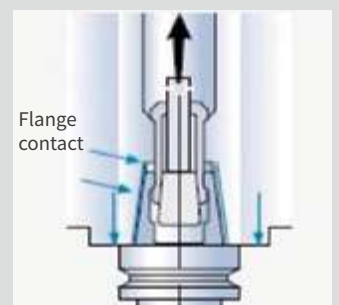
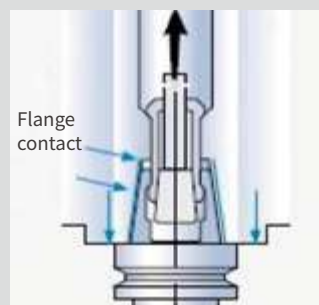

# ROTARY TABLE

Large workpiece capacity allows a variety of parts to be machined in one set up.

## Rotary table

### Max. workpiece size and weight

**Ø730 X 500** mm  
 Ø28.7 x 19.7 inch

### Max. weight

**500** kg 1102.3 lb

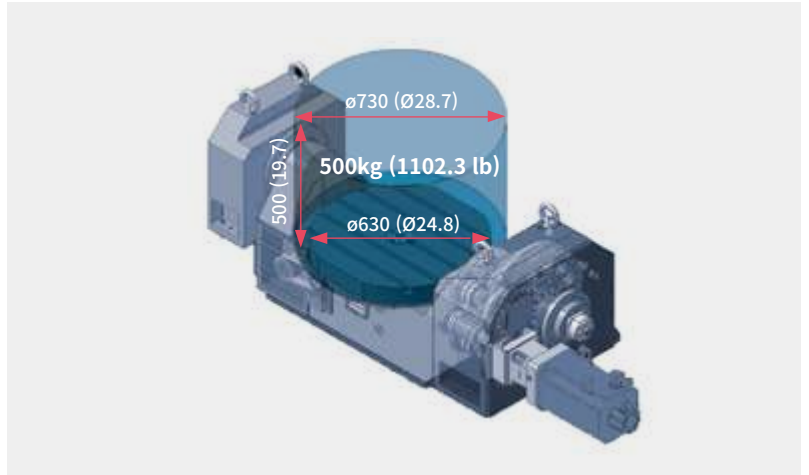

## Wider machining area

A wide machining area allows access to machine many features of large workpieces.

### Stroke

Division		A-axis	C-axis
VC 630/5AX	Travels (deg)	+30 ~ -120	360
	Rapid traverse (r/min)	20	30

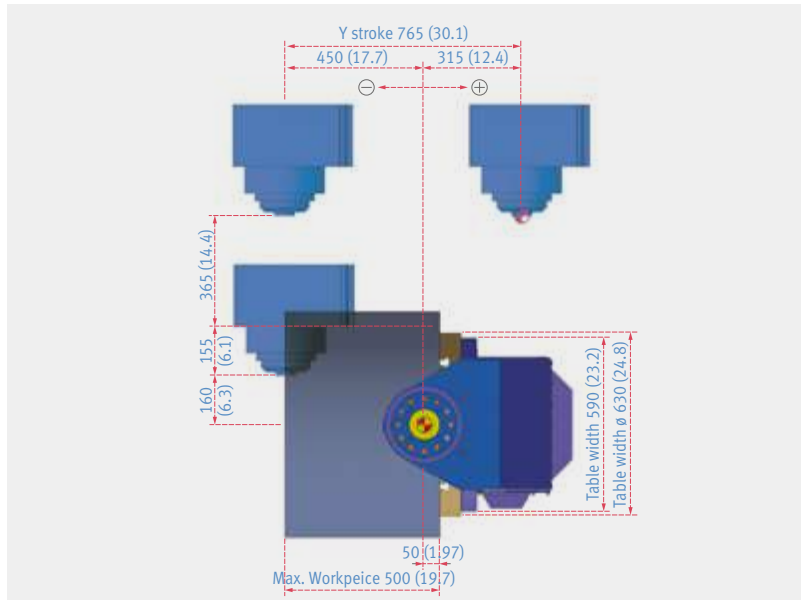

## Automatic pallet changer (APC) option

The automatic pallet changer allows setting the workpiece even during the machining process to further improve productivity.

Pallet size	500 x 500 mm (19.7 x 19.7 inch)
Max. workpiece swing (D x H)	Ø 730 x 450 mm (Ø28.7 x 17.7 inch)
Table loading capacity	500 kg (1102.3 lb)
APC Change time	30 s

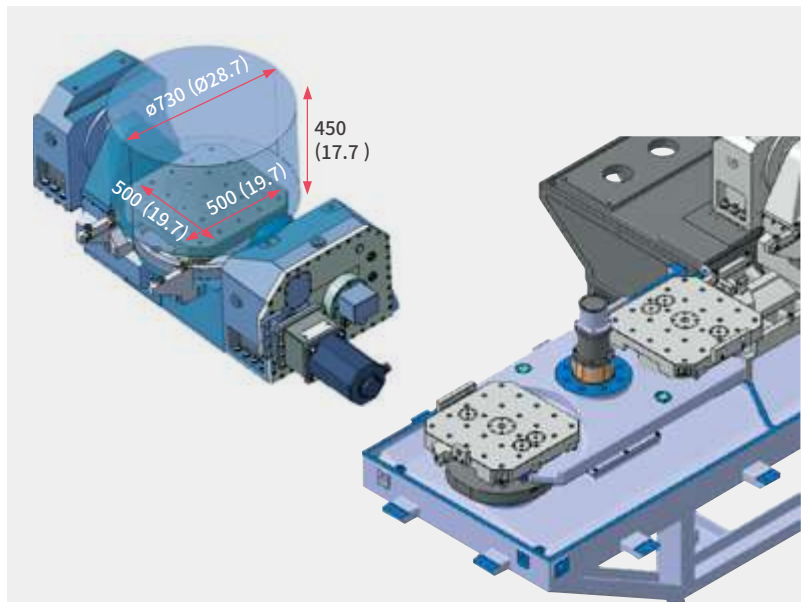

# CUTTING PERFORMANCE

The NHP Series realizes excellent machining performance thanks to its improved structure and comprehensive tooling system.

## Machining performance

### Max. chip throughput

Item	Material		Condition (SM45C, AL6061 same)
	SM45C	AL6061	
절삭량	739.2 cm <sup>3</sup> /min	2688 cm <sup>3</sup> /min	Ø80mm (3.15 in.) Face Mill (6Z)
절삭 속도	3300 mm/min (130 ipm)	7000 mm/min (275.8 ipm)	
절삭 깊이	2.5 mm (0.1 inch)	2.5 mm (0.1 inch)	
절삭 폭	64 mm (2.5 inch)	64 mm (2.5 inch)	

### Max. / min. tapping capabilities

Item	Material	
	SM45C	AL6061
Tool size	M42 x P4.5	M3 x P0.5
Feed rate	675 mm/min (26.6 ipm)	1800 mm/min (70.9 ipm)

\* The results, indicated in this catalogue are provides as example. They may not be obtained due to differences in cutting conditions and environmental conditions during measurement.

## Machining examples

<b>Tire Mold</b>			
Workpiece size	400 x 400 x 150 mm (15.7 x 15.7 x 5.9 inch)		
Material	Wood plastic		
Mold Package	332 Tuning Cycle (Heidenhain TNC 640)		
Cutting	Finish		
Tool	ø0.8mm Ball EM		
Spindle speed	24000 r/min		
Feed rate	400 mm/min (15.7 ipm)		
<b>Hinge Fitting</b>			
Workpiece size	270 x 138 x 90 mm (10.6 x 5.4 x 3.5 inch)		
Material	AL7075		
Mold Package	DSQ 1		
Cutting	Finish		
Tool	ø12 mm Ball EM		
Spindle speed	12000 r/min		
Feed rate	1000 mm/min (39.4 ipm)		
<b>Impeller</b>			
Workpiece size	D290 x 153 mm (D11.4 x 6 inch)		
Material	AL7075		
Mold Package	DSQ 3		
Cutting	Finish		
Tool	ø8 mm Ball EM		
Spindle speed	12000 r/min		
Feed rate	2500 mm/min (98.4 ipm)		

## Ball bar measurement test

Higher roundness accuracy is realized by the advanced design of machine structure and DN Solutions control system.



# TOOL CHANGER

Along with the rapid tool change that enables higher productivity, a wide range of choices is available for tool magazines.

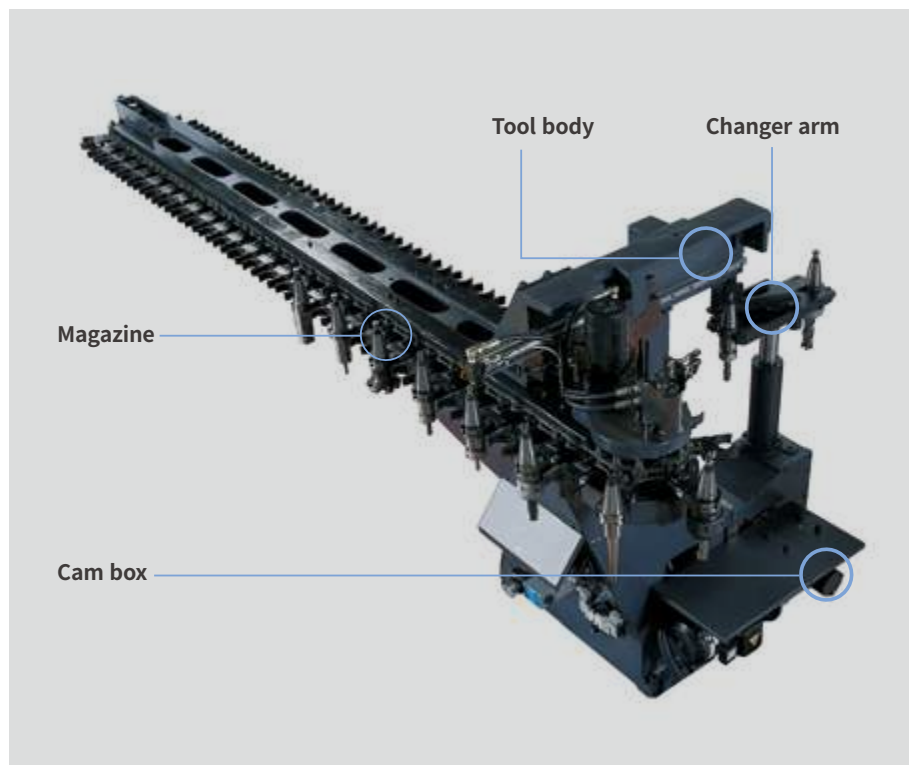

## Tool change time

**1.0 s**

## CAM type ATC

**40 ea**

60 / 81 / 101 / 121 ea option

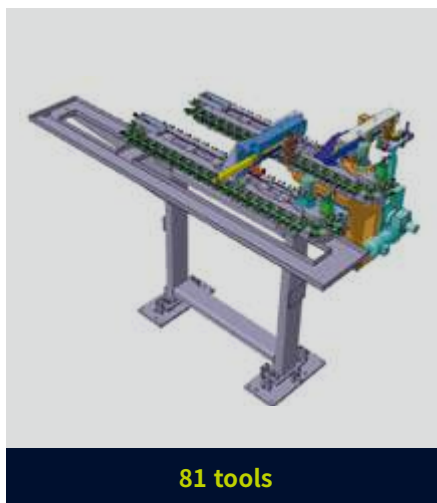

## High-capacity magazines option

A wide range of tool magazine choices (60 / 81 / 101 / 121 tools magazines) is available. The increased tool capacity will improve user convenience and efficiency.



# STANDARD | OPTIONAL SPECIFICATIONS

Diverse optional features are available to meet specific customer requirements.

Description	Features	VC 630/5AX
Air blower		○
Air gun		○
Automatic tool changer	40 Tools	●
	60 Tools	○
	80 Tools	○
	101 Tools	○
	121 Tools	○
Automatic tool length measurement	TS27R : RENISHAW	●
Chip conveyor	Hinge / Scraper / Drum filter type	○
Coolant gun		○
Coolant tank		●
DSQ (high speed / high precision contour control)	DSQ1 (AICC II_200 block)	●
	DSQ2 (DSQ1 & Data server 1GB)	○
	DSQ3 (DSQ2 & 600 block)	○
	DSQ4 (DSQ3 & 1000 block)	○
Easy Operation Package (E.O.P)	Alarm / M-code / G-code / ATC restoration guidance	●
	Table movement / Guidance on work coordinate system setup	●
Electric cabinet air conditioner		○
Electric cabinet light		○
Electric cabinet line filter		○
Linear scale	X Axis	○
	Y Axis	○
	Z Axis	○
MPG	1 MPG_PORTABLE TYPE	●
	1 MPG_PORTABLE_W/ENABLE TYPE	○
NC system	DN Solutions Fanuc i Plus	○
	FANUC 31i-5	●
	HEIDENHAIN TNC 640	○
	SIEMENS S840Dsl	○
NC system lcd size	15" DN Solutions Fanuc I Plus	●
	15" color LCD with Touch Panel	○
	15" (Color)_HEIDENHAIN	○
	15" (Color)_SIEMENS	○
Oil Skimmer	Belt Type	○
Power transformer		○
Shower coolant		○
Spindle motor power	22/18.5 kW (29.5/24.8 Hp) : FANUC (12000, 20000 r/min)	●
	91 kW (122.0 Hp) (FANUC : 30000 r/min)	○
	30/24 kW (40.3/32.2 Hp) : HEIDENHAIN (12000 r/min)	○
	30/24 kW (40.3/32.2 Hp): HEIDENHAIN (20000 r/min)	○
	30/24 kW (40.3/32.2 Hp) : SIEMENS (12000 r/min)	○
	30/24 kW (40.3/32.2 Hp) : SIEMENS (20000 r/min)	○
Spindle speed	12000 r/min	●
	20000 r/min	○
	30000 r/min	○
Test bar		○
Through spindle coolant	NONE	●
	1.5 KW_2.0 MPA	○
	4.0 KW_2.0 MPA	○
	5.5 KW_7.0 MPA_DUAL BAG FILTER	○
Work & tool counter	WORK / TOOL	○
Customized special option	Axis cooling system	○
	Auto door (w/safty edge)	○
	IKC (Intelligent Kinematic Compensation)	○
	Aerospace solution package	○
	APC	○
	Rotary joint for table	○





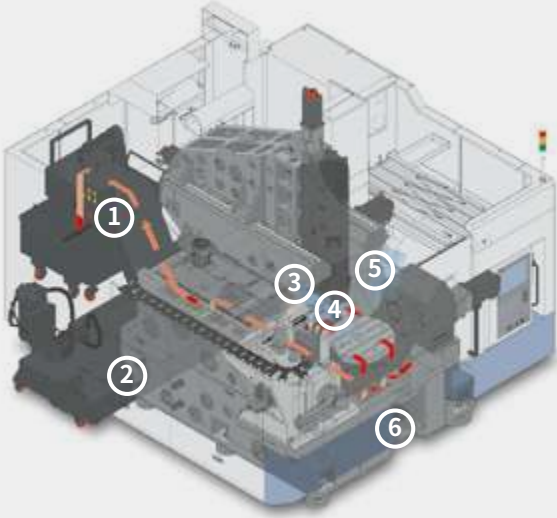

\*Please contact DN Solutions to select detail specifications.

● Standard ○ Optional x Not applicable

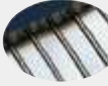
 Fire Safety Precautions | There is a high risk of fire when using non-water-soluble cutting fluids, processing flammable materials, neglecting the controlled and careful use of coolants and modifying the machine without the consent of the manufacturer. Always check the SAFETY GUIDELINES carefully before using the machine.

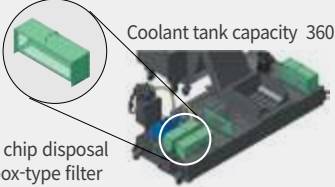
# PERIPHERAL EQUIPMENT



<p><b>1. Chip conveyor</b> <small>option</small></p>    <p>Hinge type      Scraper type      Drum filter type</p>	<p><b>2. Large capacity coolant tank built-in with chip pan and box filter</b></p>  <p>Coolant tank capacity 360L</p> <p>Easier chip disposal with box-type filter</p>
<p><b>3. Shower coolant</b> <small>option</small></p> 	<p><b>4. Coolant system</b></p> 
<p><b>5. Auto-door type top cover</b></p> <p>The top cover helps enhancing convenience when loading /unloading heavy workpiece on the processing table.</p> 	<p><b>6. Internal screw conveyor</b></p> 

## Intelligent Kinematic Compensation for 5-axis

For high accuracy 5-axis machining, Intelligent Kinematic Compensation function is recommended. This function minimizes error in complex 5-axis machining applications by maintaining tip of the tool in correct position in respect to the workpiece. In order to properly utilize this function, following four optional items are required.



### Recommended optional items

#### Software



FANUC NC: DCP-i (Developed by DN Solutions)



Heidenhain NC: Kinematic opt

#### Receiver

Recommended Option



#### Touch probe

Recommended Option



#### Datum ball

Recommended Option



#### Automatic Tool Measurement

Recommended Option



#### Master tool

Recommended Option



# FANUC 31i PLUS

Fanuc 31i Plus maximizes customer productivity and convenience.

## 15" Touch screen + New OP

DN Solutions Fanuc 31iB/B5 Plus' operation panel enhances operating convenience by incorporating common-design buttons and layout. It features a Qwerty keyboard for fast and easy data input and operation.



## iHMI touchscreen

iHMI provides an intuitive interface that uses a touchscreen for quick and easy operation.

## Range of applications

Providing various applications related to planning, machining, improvement and utility, for customer convenience.

## Fanuc 31i Plus

- 15-inch color display
- Intuitive and user-friendly design

## USB and PCMCIA card QWERTY keyboard

- EZ-Guide i standard
- Ergonomic operator panel
- 4MB Memory
- Hot keys
- Enhance AICC BLOCK
- Touch pen provided as standard



# NUMERIC CONTROL SPECIFICATIONS

**FANUC**

Item		Specifications	F31iB Plus VC 630/5AX
Controlled axis	Controlled axes		5 (X,Y,Z,C,A) (X,Y,Z,C,B)
	Simultaneously controlled axes		5 axes
	Additional controlled Axis	Add 1 Axis (5th Axis)	●
Data input/output	Fast data server		○
	Memory card input/output		●
	USB memory input/output		●
	Large capacity memory(2GB)*2	Available Option only with 15" Touch LCD (iHMI Only) *2)	○
Interface function	Embedded Ethernet		●
	Fast Ethernet		○
	Enhanced Embedded Ethernet function		●
Operation	DNC operation	Included in RS232C interface.	●
	DNC operation with memory card		●
Program input	Workpiece coordinate system	G52 - G59	●
	Addition of workpiece coordinate system	G54.1 P1 X 48 (48 pairs)	●
	Tool number command		T2 digits
	Tilted working plane indexing command	G68.2 TWP	●
Feed function	AI contour control I	G5.1 Q_, 40 Blocks	
	AI contour control II	G5.1 Q_, 200 Blocks	X
	AI contour control III	G5.1 Q_, 600 Blocks	X
	AI contour control IV	G5.1 Q_, 1000 Blocks *1)	●
	High smooth TCP		●
Operation guidance function	EZ Guidei (Conversational Programming Solution)		●
	iHMI with Machining Cycle	Only with 15" Touch LCD standard *2)	X
	EZ Operation package		●
Setting and display	CNC screen dual display function		●
Network	FANUC MTConnect		⊗
	FANUC OPC UA		⊗
Others	Display unit	10.4" color LCD	X
		15" color LCD	X
		15" color LCD with Touch Panel	●
	Part program storage size & Number of registerable programs	640M(256KB)_500 programs	X
		1280M(512KB)_1000 programs	○
		2560M(1MB)_1000 programs	○
		5120M(2MB)_1000 programs	○
		10240M(4MB)_1000 programs	●
		20480M(8MB)_1000 programs	○
		2560M(1MB)_2000 programs	○
		5120M(2MB)_4000 programs	○
		10240M(4MB)_4000 programs	○
		20480M(8MB)_4000 programs	○

\*1) The number of look-ahead blocks may be changed or limited depending on the peripheral device or the configuration of the internal NC system.

\*2) Available Option only with Fanuc i plus iHMI

● Standard ○ Optional X N/A ⊗ Available  
Network: FANUC MT Connect and FANUC OPC UA available.

# EZ WORK

The software developed by DN Solutions's own technology provides numerous functions designed for convenient operation.

## EZ work

The EZ work package delivers speed and efficiency. This menu-driven innovation not only helps customers reduce setup times, but also simplifies common tasks and procedures, reducing the potential for errors. EZ work reduces operating time, protects machinery, enhances quality and speeds up maintenance interventions.



### Thermal Compensation

A function to maintain high-precision machining quality by analyzing and correcting the amount of thermal displacement of a structure through a temperature sensor



### M/G-Code List

Functional description of M code and G code



### Tool Management

Function to manage tool information [Tool information / Tool No. / Tool condition (normal, large diameter, worn / damaged, used for the rst time, manual) / Tool name]



### Operation Rate

Machine operation history management function by date based on load



### Adaptive Feed Control

Function to control feedrate so that the cutting can be carried out at a constant load



### IKC (DCP-I)

The function to compensate the position of the workpiece and the tool tip to be constant regardless of the rotation of the rotating shaft error



### Spindle Warm Up

A function that assists spindle warm-up for spindle life when the spindle has not been used for a certain period of time



### ATC Recovery

Function to view detailed info with recommended actions and to perform step-by-step operation manually (when an alarm is triggered during an ATC operation)



### Addition of Optional Block Skip

In addition to the OPTIONAL BLOCK SKIP of the operation panel, the function to skip a specific block selected in the machining program

# CONVENIENT OPERATION

## HEIDENHAIN TNC640

### Superior hardware specifications

The TNC 640 features optimized motion control, short block processing times and special control strategies. Together with its uniform digital design and its integrated digital drive control (including inverters), it enables you to achieve high machining speeds and the best possible contour accuracy.

- 15" display
- 21GB Storage memory
- 1024 look ahead blocks
- High user convenience with folder structure data management



### Conversational convenient function



Data are controlled in the folder structure; convenient communication via USB devices



KinematicOpt & KinematicComp option  
(Touch probe cycle for automatic measurement)

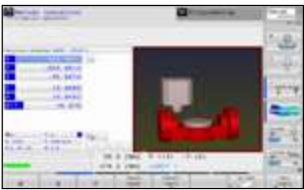

Collision protection system option



Adaptive feed control option



Various built-in pattern cycles for a wider scope of application (Software standard)

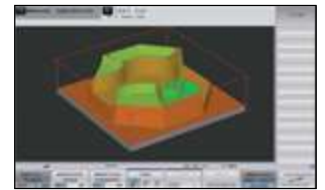

Graphic simulation

## NUMERIC CONTROL SPECIFICATIONS



HEIDENHAIN

Item		Specifications	TNC640 VC 630
Controlled axis	Controlled axis		5 (X,Y,Z,C,A)
	Simultaneously controlled axis		5 axes
Data input/output	USB memory input/output		●
Interface function	Embedded ethernet		●
Feed function	Look-ahead	5000 blocks	●
Axis compensation	KinematicsOpt	Automatic measurement and optimization of machine kinematics	●
Collision monitoring	Dynamic collision monitoring (DCM)		○
Network	MTConnect		⊕
Others	Display unit	15.1 inch TFT color flat panel	●
		15.1 inch TFT color with Touch Panel	○
		19 inch TFT color flat panel	○
		19 inch TFT color with Touch Panel	○
	Part program storage size & number of registerable programs	21GB 1.8GB	● X

● Standard ○ Optional X Not Available ⊕ Available

# CONVENIENT OPERATION

## SIEMENS 840D

### 15.6" screen + new operation panel

The newly-designed operation panel improves the customer convenience by incorporating and using common-design buttons and layouts, and includes the familiar QWERTY keyboard for fast and easy operation.

- 15.6" display
- 10MB high capacity user memory
- USB & ethernet (standard)
- QWERTY keyboard (standard)
- High-speed calculation and simulation can be fulfilled by improved processor functionality



### Conversational convenient function



Simulation and machining contour monitoring

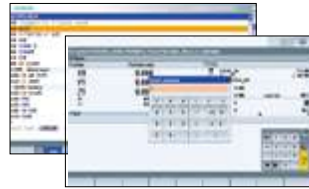

Smart function



Side screen widget



5-axis kinematic measuring cycles

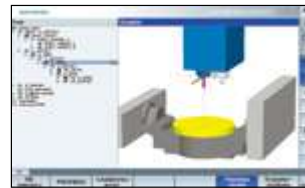

3D collision avoidance and collision avoidance ECO



Shop mill part programming

## NUMERIC CONTROL SPECIFICATIONS

SIEMENS

	Item	Specifications	S840Dsl
			VC 630/5AX
Controlled axis	Controlled axes	-	5 axis
	Simultaneously controlled axes	-	5 axis
Data input/output	Memory card input/output	(Local drive)	●
	USB memory input/output		●
Interface function	Ethernet	(X130)	●
Operation	On network drive	(without EES option, Extcall)	●
	On USB storage medium, e.g. memory stick	(without EES option, Extcall)	●
Program input	Workpiece coordinate system	G54 - G57	●
	Addition of workpiece coordinate system	G505 - G599	●
Interpolation & Feed function	Advanced surface		●
	Top surface		○
Programming & Editing function	Look ahead number of block	S/W version 4.8	1000
	3D simulation, finished part		●
Operation Guidance Function	Simultaneous recording		●
	Measure kinematics		●
	DXF Reader for PC integrated in SINUMERIK Operate		○
Setting and display	ShopMill		●
	EZ Work		●
Network	Operation via a VNC viewer		●
	MTCConnect		⊕
Etc. function	OPCUA		○
	15.6" color display with touch screen		●
	19" color display without touch screen		○
	21.5" color display with touch screen		○
	CNC user memory	10 MB	●
Expansion by increments	2 ~ 12 MB	○	
Collision avoidance		○	
Collision avoidance ECO (machine, working area)		●	

● Standard ○ Optional X Not Available ⊕ Available

# POWER | TORQUE

## FANUC 31i-5

12000 r/min

Spindle motor power (30min/cont.) : 22/18.5 kW (29.5/24.8 Hp)

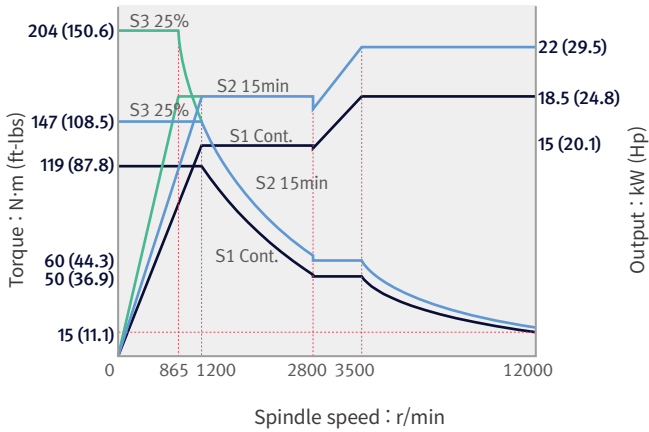

20000 r/min option

Spindle motor power (30min/cont.) : 22/18.5 kW (29.5/24.8 Hp)

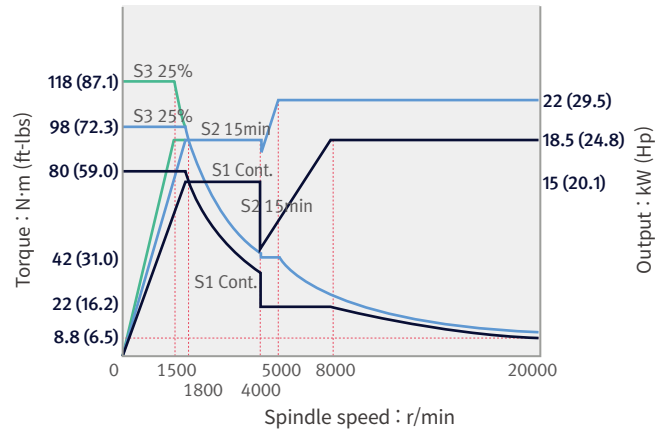

30000 r/min option

Spindle motor power (30min/cont.) : 91 kW (122.0 Hp)

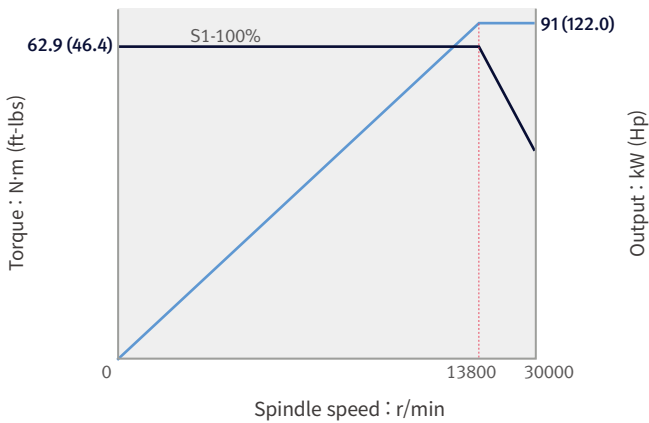

## HEIDENHAIN TNC 640 option

12000 {20000 option} r/min

Spindle motor power (30min/cont.) : 30/24 kW (40.2/32.2 Hp)

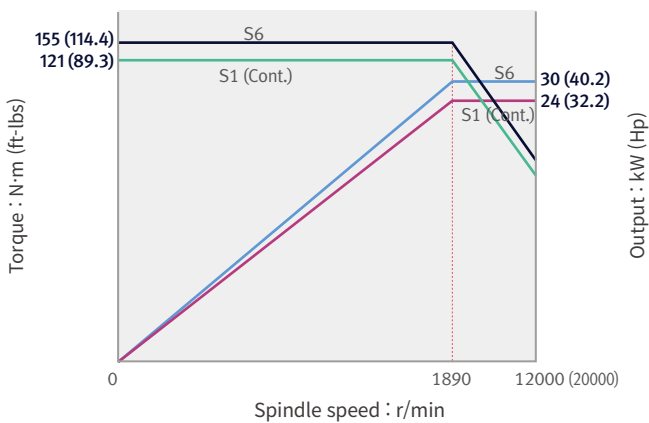

## SIEMENS 840 Dsl option

12000 {20000 option} r/min

Spindle motor power (30min/cont.) : 30/24 kW (40.2/32.2 Hp)

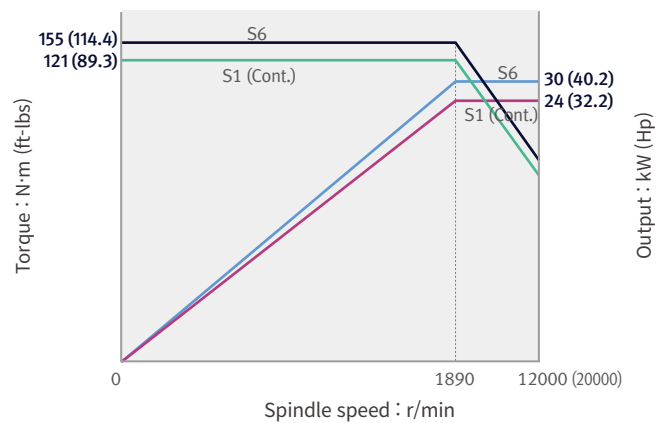

# DIMENSIONS

VC 630/5AX (Standard type)

Units : mm (inch)

TOP

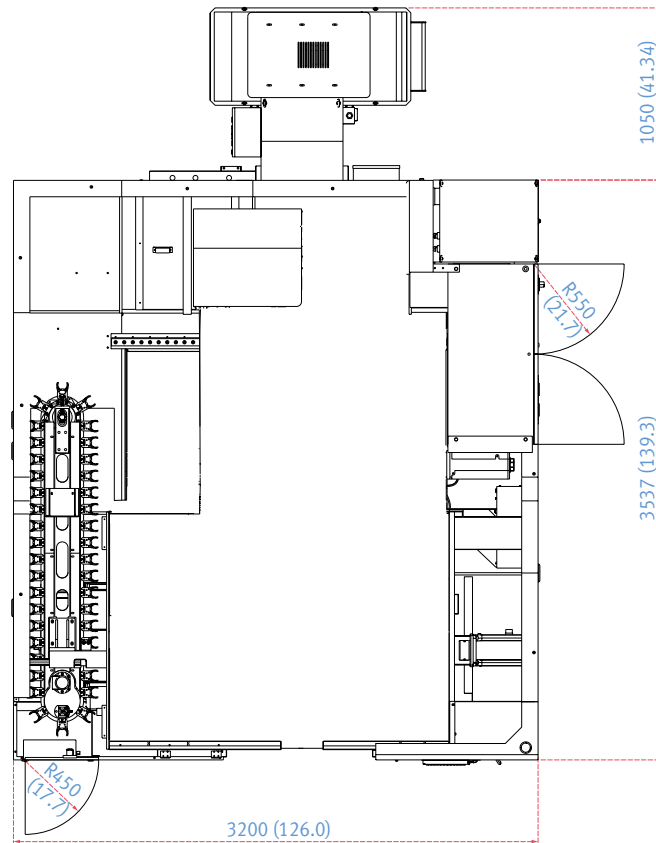

FRONT

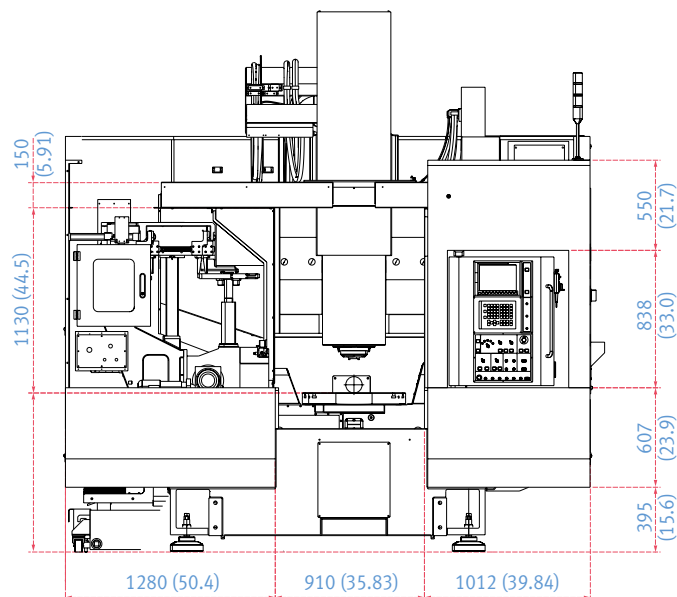



# DIMENSIONS

VC 630/5AX (APC type)

Units : mm (inch)

TOP

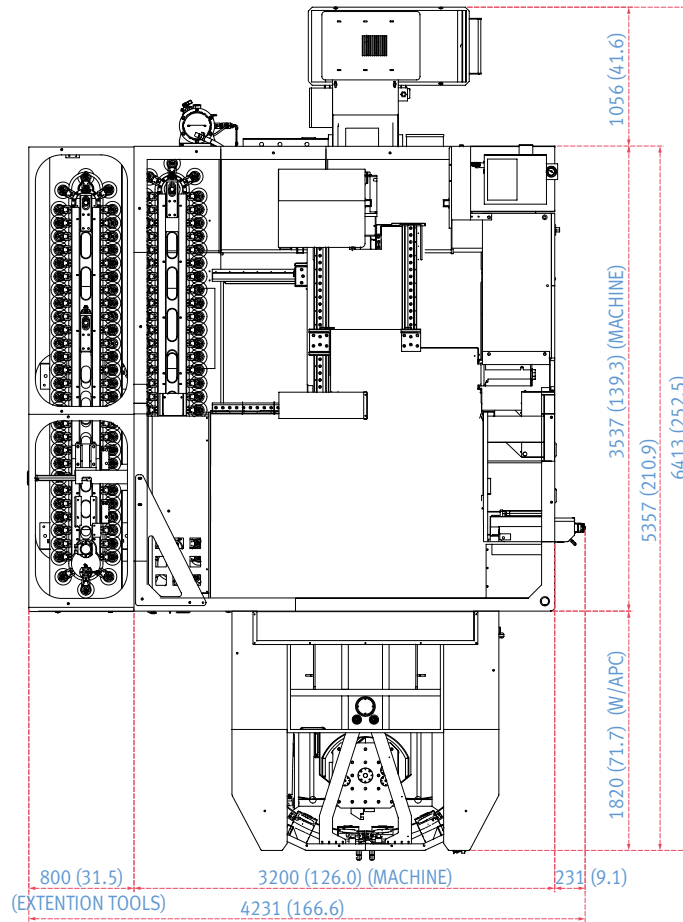

FRONT

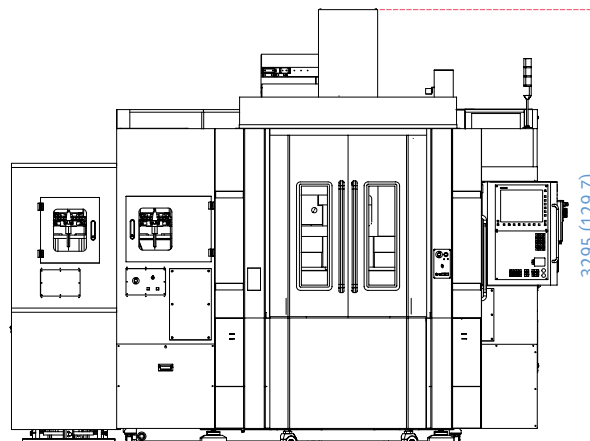

\* Some peripheral equipment can be placed in other areas.



# TOOL SHANK

## BT40

Units : mm (inch)

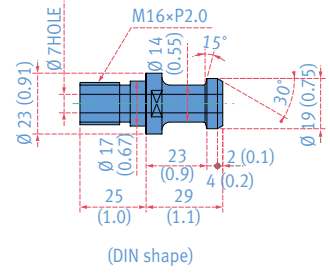
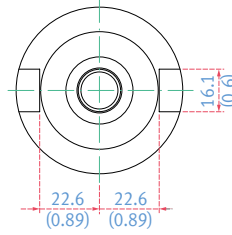
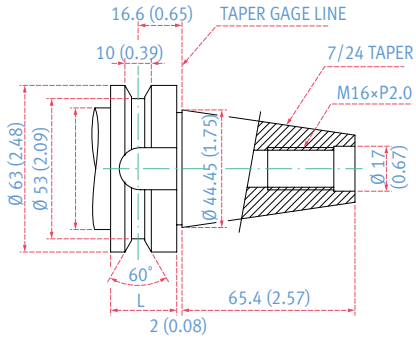

## CAT40

Units : mm (inch)

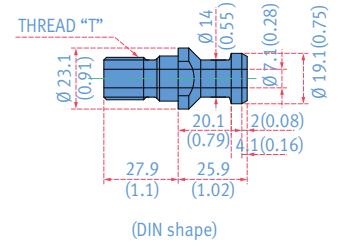
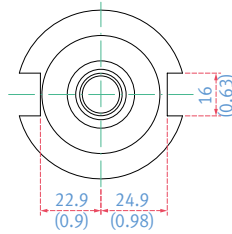
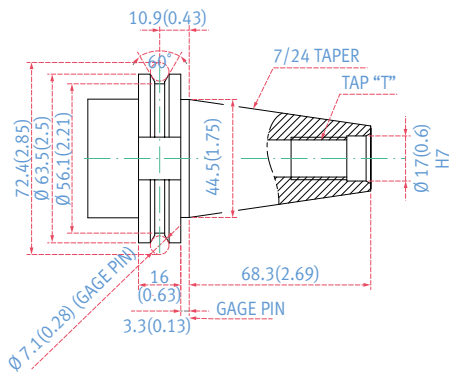

## DIN40

Units : mm (inch)

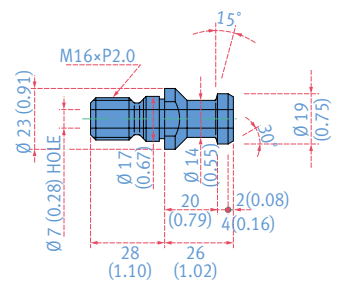
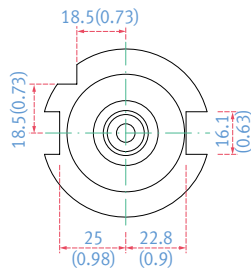
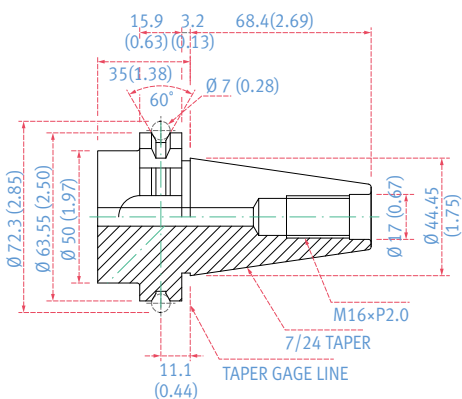

# MACHINE SPECIFICATIONS

Description		Unit	VC 630/5AX	VC 630/5AX with APC	
Travels	X-axis	mm (inch)	650 (25.6)		
	Y-axis	mm (inch)	765 (30.1)		
	Z-axis	mm (inch)	520 (20.5)		
	A-axis	deg.	150 (+30~ -120)		
	C-axis	deg.	360		
	Distance from spindle nose to table top	mm (inch)	210 ~ 730 (8.3~28.7)	160 ~ 680 (6.3~26.8)	
	Distance from spindle center to column guideway	mm (inch)	220 (8.7)		
Feedrate	Rapid traverse rate (X / Y / Z)	m/min (ipm)	40 / 40 / 36 (1574.8 / 1574.8 / 1417.3)		
	Rapid traverse rate (A / C)	r/min	20 / 30		
	Cutting feedrate (X / Y / Z)	mm/min (ipm)	18000 (708.7)		
	Cutting feedrate (A / C)	deg/min	7200		
Table	Table size	mm (inch)	ø 630 (24.8)	500 x 500 (19.7 x19.7)	
	Table loading capacity	kg (lb)	500 (1102.3)		
	Max. workpiece swing diameter x height	mm (inch)	ø 730 x 500 (28.7 x 19.7)	ø 730 x 450 (28.7 x 17.7)	
	Minimum table indexing angle	-	0.001		
Spindle	Max. spindle speed	r/min	12000 {20000 / 30000}		
	Spindle taper	-	ISO#40 7 / 24 Taper		
	Max. spindle torque	N·m (ft·lb)	204 (150.6) (25% ED) {118 (87.1) (25% ED)} {62.9 (46.4)}		
Automatic tool changer	Type of tool shank	-	MAS403 BT40		
	Tool storage capacity	ea	40 {60 / 81 / 101 / 121}		
	Max. tool diameter	mm (inch)	ø 80 (59.0)		
	Max. tool diameter without adjacent tools	mm (inch)	ø 125 (92.3)		
	Max. tool length	mm (inch)	300 (221.4)		
	Max. tool weight	kg (lb)	8 (17.6)		
	Max. tool moment	N·m (ft·lb)	5.88 (4.3)		
	Method of tool selection	-	Fixed address		
	Tool change time (tool-to-tool)	s	1.0		
Tool change time (chip-to-chip)	s	8.5			
Automatic pallet changer	Number of pallet	ea	-	2	
	Type	-	-	Rotary shuttle	
	Pallet change time	s	-	30	
Motor	Spindle motor power	kW (Hp)	FANUC 31i-5 : 22/18.5 {91} (29.5/24.8 {122.0}) {HEIDENHAIN TNC 640 : 30/24 (40.3/32.2 Hp) : 12000 r/min, 30/24 (40.3/32.2 Hp) : 20000 r/min} {SIEMENS 840 Dsl : 30/24kw (40.3/32.2 Hp) : 12000 r/min, 30/24kw (40.3/32.2 Hp) : 20000 r/min}		
Power source	Electric power supply	kVA	53.3		
	Compressed air supply	MPa	0.54		
Tank capacity	Coolant tank capacity	L (galon)	360 (95.1)		
	Lubrication tank capacity	L (galon)	1.32 (0.4)		
Machine Dimensions	Machine dimension (L x W x H)	mm (inch)	3537(4587 : with chip conveyor ) x 3200 x 3295 (139.3(180.6 : with chip conveyor) x 126 x 129.7)	5357(with chip conveyor : 6413) x 4231 x 3295 (210.9(with chip conveyor : 252.5) x 166.6 x 129.7)	
	Machine weight	kg (lb)	12500 (27557.4)	16000 (35273.4)	
Control	NC System		Fanuc 31iB Plus {DN Solutions Fanuc i Plus / SIEMENS 840 Dsl / HEIDENHAIN TNC 640}		

# WHY 5-AXIS MACHINING?

## Single setup efficiency

5-axis machining allows you to approach the workpiece from all angles, with complete access to five sides of the part in a single setup. This reduces the overall number of part setups compared to traditional machining, which minimizes machine downtime and maximizes chip making time.



## Improved part accuracy

When making parts with multi-sided features using traditional 3-axis machining, multiple part setups are required. This means new inaccuracies can arise each time the workpiece is repositioned. 5-axis machining eliminates stacked tolerances and improves overall part dimensional accuracy.

## Extended machine shop capability

DN Solutions 5-axis machines open up new doors for your machine shop. The increased efficiency will make you instantly more competitive, and full 5-axis machining capabilities give you the opportunity to quote on jobs that previously weren't possible. So, what are you going to make today?



“Compared with similar machines from Japan or Europe, DN Solutions has the same level of precision and quality at a better value for money.”

– *OMGM Group, Italy*

“Our DN Solutions 5-axis is making complex, high precision parts for aerospace and defense. Cycle times have been reduced dramatically.”

– *Aerotech Precision Manufacturing, Great Britain*

The DN Solutions promise, MACHINE GREATNESS, has two important meanings. The first is simple: DN Solutions makes great machines. The second is a challenge to our end-users. With a product line that is this comprehensive, accurate and reliable, we equip our customers to machine greatness. The big question: **Why should you choose DN Solutions over other options?**

Here's why...



**MACHINE  
GREATNESS™**



WHAT YOU MAKE AND HOW YOU MAKE IT MATTERS—SO MAKE IT  
GREAT WITH DN SOLUTIONS.

### UNBEATABLE MACHINES

You won't find a more comprehensive range or a better combination of value, performance and reliability anywhere else.

### ROBUST PRODUCT LINE

We offer an impressive range of machine models and hundreds of configurations. Whatever your machining needs and requirements, there's a DN Solutions for you.

### READILY AVAILABLE - ANYWHERE IN THE WORLD

Machining centres (including 5-axis machines), lathes, multi-tasking turning centres and mill-turn machines, and horizontal borers with best-in-class specifications are all available...ready to install.

### EXPERT SERVICE

Our dedicated, experienced and knowledgeable team is totally committed to improving your productivity, growth and success.

# RESPONDING TO CUSTOMERS ANYTIME, ANYWHERE

## DN Solutions Global Network

DN Solutions provides systems-based professional support services, before and after the machine tool sale, by responding quickly and efficiently to customers. By supplying spare parts, product training, field service and technical support, we provide the expert care, attention and assistance our customers expect from a market leader.

Global sales and service support network		<b>51</b>	<b>Technical centers</b> Technical center, Sales support, Service support, Parts support
<b>4</b>	<b>Corporations</b>	<b>200</b>	<b>Service posts</b>
<b>155</b>	<b>Dealer networks</b>	<b>3</b>	<b>Factories</b>



## CUSTOMER SUPPORT AND SERVICES

**We're there for you whenever you need us.**

We help our customers operate at maximum efficiency by providing them with a range of tried, tested and trusted services - from pre-sales consultancy to post-sales support.



### Field services

- On-site service
- Machine installation and testing
- Scheduled preventive maintenance
- Machine repair service



### Parts supply

- Supplying a wide range of original DN Solutions spare parts
- Parts repair service



### Training

- Programming, machine setup and operation
- Electrical and mechanical maintenance
- Applications engineering



### Technical support

- Supports machining methods and technology
- Responds to technical queries
- Provides technical consultancy



[dn-solutions.com](http://dn-solutions.com)

**Head Office**

22F T Tower, 30, Sowol-ro 2-gil  
Jung-gu, Seoul, Korea, 04637

Tel: +82-2-6972-0370/0350  
Fax: +82-2-6972-0400

**DN Solutions America**

19A Chapin Road, Pine Brook  
New Jersey 07058, United States

Tel: +1-973-618-2500  
Fax: +1-973-618-2501

**DN Solutions Europe**

Emdener Strasse 24, D-41540  
Dormagen, Germany

Tel: +49-2133-5067-100  
Fax: +49-2133-5067-111

**DN Solutions India**

No.82, Jakkuar Village  
Yelahanka Hobli, Bangalore-560064

Tel: + 91-80-2205-6900  
E-mail: [india@dncompany.com](mailto:india@dncompany.com)

**DN Solutions China**

Room 101,201,301, Building 39 Xinzhuan  
Highway No.258 Songjiang District  
China Shanghai (201612)

Tel: +86 21-5445-1155  
Fax: +86 21-6405-1472

**Sales inquiry**

[sales@dncompany.com](mailto:sales@dncompany.com)

\* For more details, please contact DN Solutions.

\* Specifications and information contained within this catalogue may be changed without prior notice.