



HIGH PRODUCTIVITY TWIN TABLE  
VERTICAL MACHINING CENTER

# VC

430 • 510



**DN SOLUTIONS**

## VC 430 • VC 510

---

The VC430/VC510 twin table vertical machining center provides features to optimize high precision during long periods of operation. These machines are based on a moving column structure, and by utilizing the rapid workpiece change by rotating pallet and high powered spindle, productivity is maximized.





### **HIGH-RIGIDITY AND COLUMN-MOVING STRUCTURE**

- High-rigidity cast structure is excellent for vibration absorption and minimizes deformation under heavy load. The column moving design guarantees high accuracy even after a prolonged period of operation and minimizes footprint.

### **HIGH-SPEED AUTO PALLET CHANGER**

- The dual table equipped with standard auto-indexing pallet enables stable positioning and improved productivity with minimized idle time.

### **CONVENIENCE**

- Diverse optional features are available for customized requirements.

# BASIC STRUCTURE

The high rigidity machine structure maintains stable accuracy for long periods even during heavy duty cutting.

## Stable column moving structure

The moving column structure eliminates the root causes of fatigue and vibration caused by high frequency rapid movements over long periods of running and optimizes durability and accuracy. The machine footprint is also minimized.

## Travel distance (X / Y / Z axis)

VC 430

**560 / 430 / 570** mm

22.0 / 16.9 / 22.4 inch

VC 510

**762 / 516 / 570** mm

33.0 / 20.3 / 22.4 inch

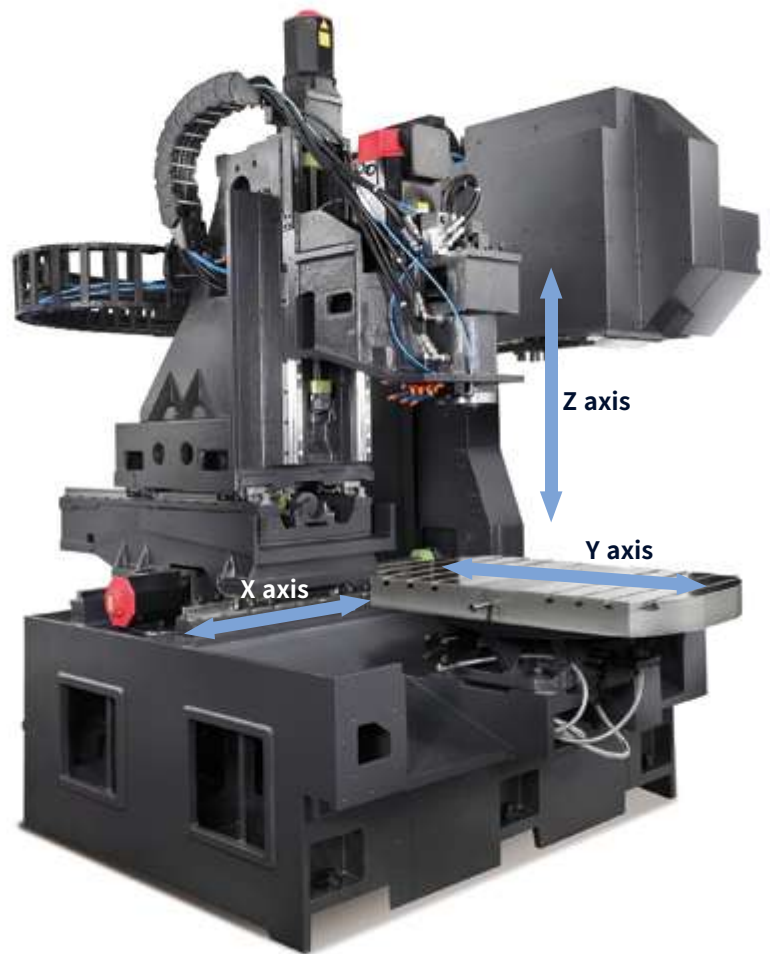

## Rapid traverse rate (X / Y / Z axis)

VC 430

**40 / 40 / 36** m/min

1574.8 / 1574.8 / 1417.3 ipm

VC 510

**40 / 40 / 32** m/min

1574.8 / 1574.8 / 1259.8 ipm

## High-precision feed structure

Roller-type Linear Guideway and the highly rigid coupling are adopted for improving rigidity and accuracy of the linear feed system in X, Y and Z directions.



Rigidity and accuracy of feed system are improved with Roller Type LMG and Coupling.



Roller type linear guideway

# SPINDLE

The high speed spindle maintains accuracy during fine machining and also provides sufficient power for heavy duty cutting performance.

## High-speed, high-precision spindle

The high-speed spindle of 10,000 (12,000) rpm is supported high-precision bearing for ensuring stable accuracy under high speed cutting operation. In addition, a spindle motor of higher power is mounted for heavy duty cutting.

### Max. spindle speed

**10000** r/min

**12000** r/min option

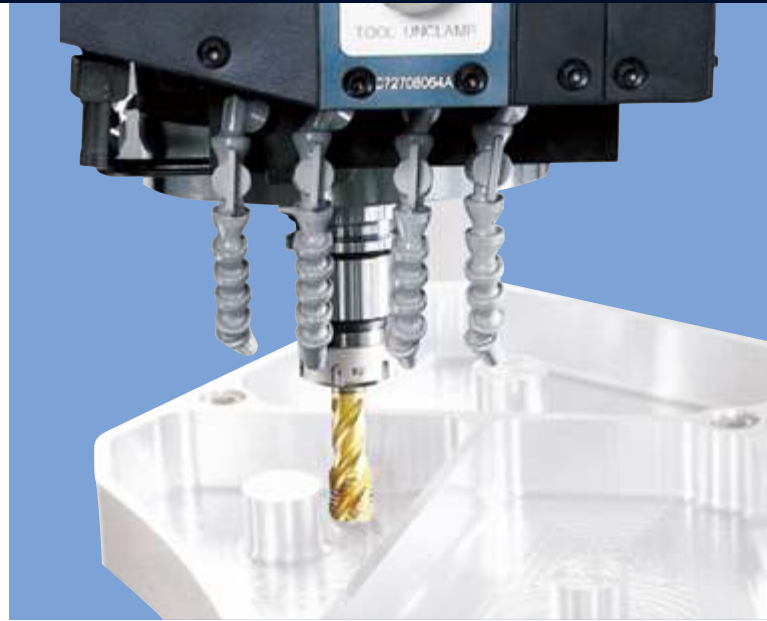

## High speed spindle

**10000** r/min

\* Belt type

**12000** r/min option

\* Direct type

Motor power (30min/con.)

**18.5 / 15** kW

24.8 / 20.1 Hp

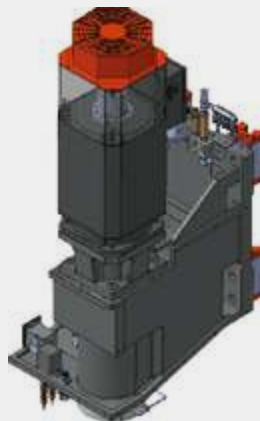

## High torque spindle

**6000** r/min option

\* Belt type

\* Only VC 510

Motor power (30min/con.)

**15/11** kW

20.1 / 14.8 Hp

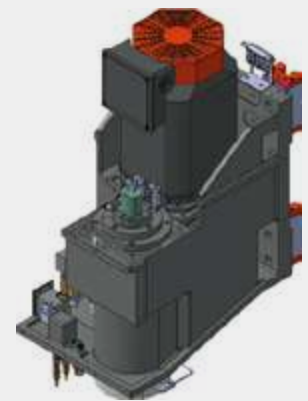

## Spindle head cooling system

The spindle cooling system maintains temperature relative to the ambient value and circulates cooling oil around the bearings to reduce thermal growth due to high speed running over long periods.



\* Not available for 6000 rpm.

## Dual contact spindle

Tool rigidity is enhanced by the firm clamping of the spindle. Tool lifecycle and cut-surface roughness have been improved as a result of the reduced vibration realized by the dual contact spindle.

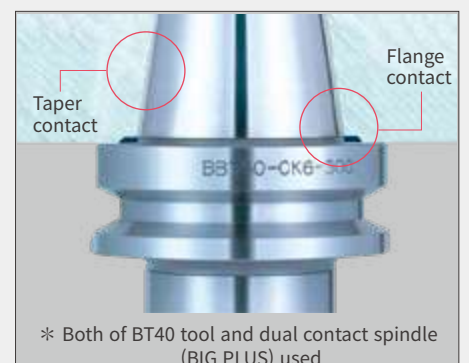

# CUTTING PERFORMANCE

## Machining performance

Delivers excellent performance under diverse machining conditions.

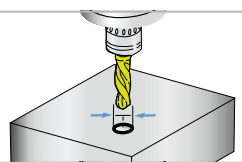
<b>Face mill Carbon steel (SM45C)</b>			
ø80mm Face mill (6Z)			
Machining rate (cm <sup>3</sup> /min(inch <sup>3</sup> /min))	Spindle speed (r/min)	Feedrate (mm/min(ipm))	
432 (26.4)	1500	2700 (106.3)	
<b>Face mill Gray casting (GC25)</b>			
ø80mm Face mill (6Z)			
Machining rate (cm <sup>3</sup> /min(inch <sup>3</sup> /min))	Spindle speed (r/min)	Feedrate (mm/min(ipm))	
691 (42.2)	1500	3600 (141.7)	
<b>Face mill Aluminum (AL6061)</b>			
ø80mm Face mill (6Z)			
Machining rate (cm <sup>3</sup> /min(inch <sup>3</sup> /min))	Spindle speed (r/min)	Feedrate (mm/min(ipm))	
1785 (108.9)	1500	5580 (219.7)	
<b>End mill Carbon steel (SM45C)</b>			
ø30mm Endmill (6Z)			
Machining rate (cm <sup>3</sup> /min(inch <sup>3</sup> /min))	Spindle speed (r/min)	Feedrate (mm/min(ipm))	
36 (2.2)	222	80 (3.1)	
<b>U-drill Carbon steel (SM45C)</b>			
U-drill Carbon steel (SM45C)			
Machining rate (cm <sup>3</sup> /min(inch <sup>3</sup> /min))	Spindle speed (r/min)	Feedrate (mm/min(ipm))	
172 (10.5)	750	84 (3.3)	
<b>Tap Carbon steel (SM45C)</b>			
Tap Carbon steel (SM45C)			
Tool (mm)	Spindle speed (r/min)	Feedrate (mm/min(ipm))	
M30 x P3.5	212	742(29.2)	

\* The results, indicated in this catalogue are provides as example. They may not be obtained due to differences in cutting conditions and environmental conditions during measurement.

## Machining accuracy

### Roundness

6.0 μm

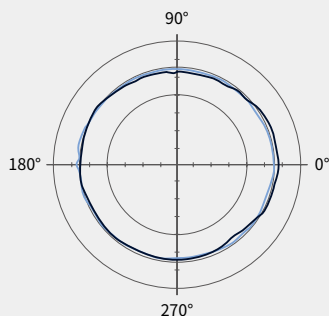

### Roughness

Ra 0.2 μm

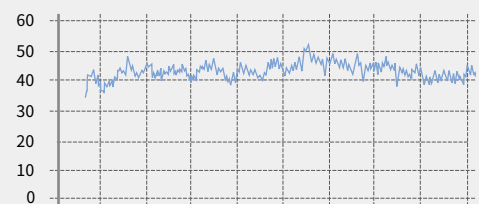

<b>Model</b>	VC430 / 510
<b>Material</b>	A7075F
<b>Tool</b>	Endmill ø12mm (4 blades)

<b>Spindle speed</b>	10000 r/min
<b>Feedrate</b>	1500 mm/min

\* The results, indicated in this catalogue are provides as example. They may not be obtained due to differences in cutting conditions and environmental conditions during measurement.

# TOOL CHANGER | PALLET

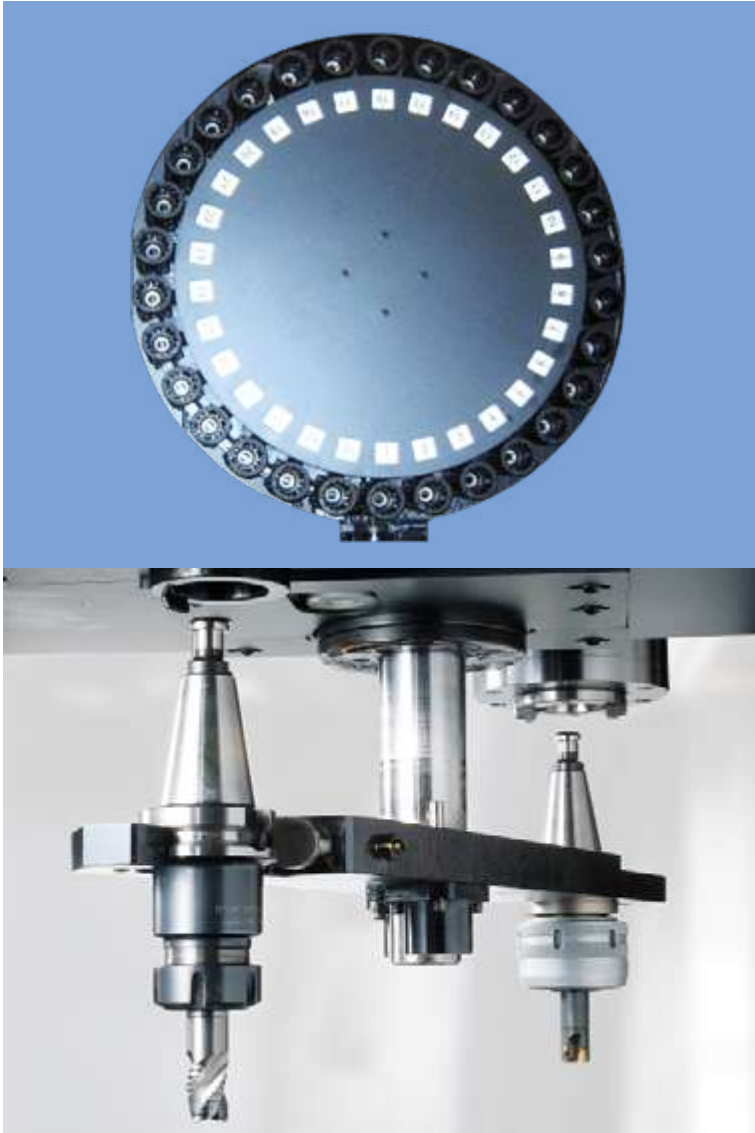

## Tool magazine

The drum-shape tool magazine mounted on the right of the machine is driven by the motor and the cam to guarantee high reliability. The magazine can be expanded to hold maximum 40 tools when optionally selected.

## Tool storage capacity

**30** Tools

**40** Tools option

## Automatic tool changer

Rapid tool change at speed of 3 seconds for T-T to enhance productivity. The drum-shape ATC mounted on the right of the machine is interoperated with the CAM.

## Tool change time (T-T-T)

**1.3 s / 1.6 s** option

## Tool change time (C-T-C)

**4.3 s / 4.6 s** option

## PALLET

### Automatic rapid pallet changer (APC)

- The dual table with the standard automatic indexing pallet is of rack & pinion type and rotates through 180 degrees. It features a 6 ton clamping force.
- The table with the horizontal machine bed directly connected allows stable positioning and minimal non-cutting time to improve productivity.
- Hydraulic lines for fixtures and electrical cables for rotary tables can be supplied via the central column of the indexing pallet, thus allowing pallet rotation whilst maintaining services connection.

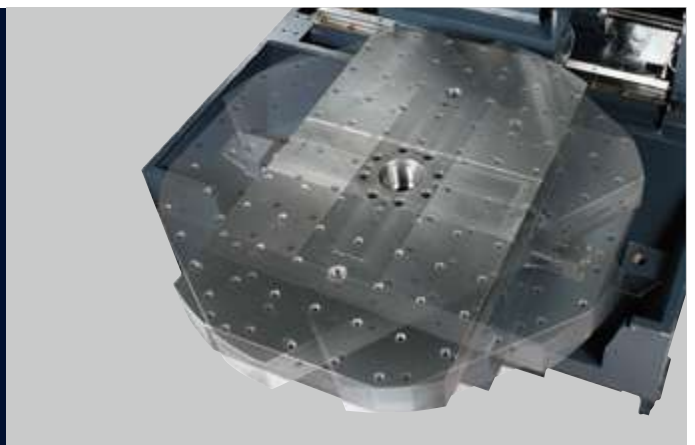

Model	VC 430	VC 510
Pallet change time	5 s	5.5 s
Pallet loading capacity	2-300 kg (2-661.4 lb)	2-350 kg (2-771.6 lb)
Pallet size	2-712 × 490 mm (2-28.0 x 19.3 inch)	2-860 × 570 mm (2-33.9 x 22.4 inch)

# STANDARD | OPTIONAL SPECIFICATIONS

A range of options is available to suit individual requirements.

Description	Features	VC 430	VC 510
Air blower		○	○
Air gun		○	○
Auto tool changer	30 Tools	●	●
	40 Tools	○	○
Coolant chiller		○	○
Coolant gun		○	○
Coolant tank		●	●
Coolant level switch : Sensing level - Low / High		○	○
Data server	NONE	●	●
	FUNCTION & MEMORY CARD_1GB	○	○
Electric cabinet air conditioner		○	○
Electric cabinet light		○	○
Electric cabinet line filter		○	○
Hydraulic fixture interface	NONE	●	●
	A LINE_1 PAIR_EACH PALLET	○	○
MPG	1 MPG_PORTABLE TYPE	●	●
	1 MPG_PORTABLE_W/ENABLE TYPE	○	○
NC system	DN Solutions FANUC i	●	●
Oil cooler	6000 r/min	X	X
	10000 r/min	●	●
	12000 r/min	●	●
Oil Skimmer	Belt type	○	○
Pallet type	2_30-M16 X P2.0 TAP	●	X
	2_4-100 X 18H8 T-SLOTS	○	X
	2_42-M16 X P2.0 TAP	X	●
	2_5-100 X 18H8 T-SLOTS	X	○
Pneumatic fixture interface	P/T LINE_1 PAIR_EACH PALLET	●	●
	A/B LINE_1 PAIR_EACH PALLET	○	○
Power transformer		○	○
Rigid tapping		●	●
Shower coolant	NONE	●	●
	1.1 kW_0.1MPA_200L/MIN_220V	○	○
Spindle motor power	15/11 kW	X	○
	18.5/15 kW	●	●
Spindle speed	6000 r/min	X	○
	10000 r/min	●	●
	12000 r/min	○	○
Test bar		○	○
Through spindle coolant	NONE	●	●
	1.5 KW_2.0 MPA	○	○
	4.0 KW_2.0 MPA	○	○
	5.5 KW_7.0 MPA_DUAL BAG FILTER	○	○
Work & tool counter	WORK / TOOL	○	○
Customized Special Option	COOLANT SYSTEM - HIGH PRESSURE TSC1	○	○
	APPLY GREASE LUBRICATION	○	○

\* Please contact DN Solutions for detailed specification information.

● Standard ○ Optional X Not applicable

 **Fire Safety Precautions** | There is a high risk of fire when using non-water-soluble cutting fluids, processing flammable materials, neglecting the controlled and careful use of coolants and modifying the machine without the consent of the manufacturer. Always check the SAFETY GUIDELINES carefully before using the machine.



# PERIPHERAL EQUIPMENT

## Through-spindle coolant spray system option

Coolant supply around the spindle nose is standard equipment. The coolant tank is separated from the machine structure to prevent heat transfer. Through spindle coolant (TSC) is an option.



Through Spindle Coolant



Flood Coolant

## Coolant chiller option (strongly recommended)

Heat is transferred from the coolant during cutting to the machine structure and can cause thermal deformation. To maintain optimum machining accuracy, a coolant chiller is recommended which recirculates the coolant and controls its temperature. This significantly improves overall precision.

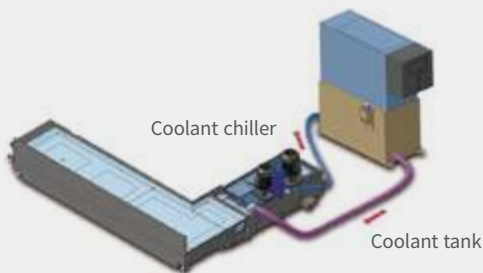

## AWC system option

The optimized solution to realize compact automation system through automatic work-piece change system.



Max. workpiece dimensions	Unit	Count	Max. loading	Max. construction height on the pallet
250 x 250 (9.8x9.8) or ø 300 (11.8)	mm (inch)	12	130kg (286.6lb)	350mm (13.8inch)
320 x 320 (12.6x12.6) or ø 360 (14.2)	mm (inch)	10	250kg (551.1lb)	
350 x 350 (13.8x13.8) or ø 400 (15.7)	mm (inch)	8		
400 x 400 (15.7x15.7) or ø 450 (17.7)	mm (inch)	6		
500 x 500 (19.7x19.7) or ø 550 (21.7)	mm (inch)	4		

### Pallet Storage-Table Configuration

Unit : mm (inch)

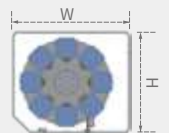

W X H = 1,900 X 1,700

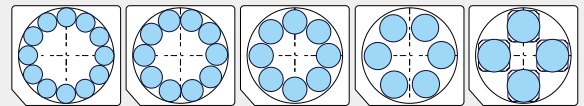

250 (9.8) X 250 (9.8)    320 (12.6) X 320 (12.6)    350 (13.8) X 350 (13.8)    400 (15.7) X 400 (15.7)    500 (19.7) X 500 (19.7)

## Interface for additional equipment (4 axes)

### Fixture check list(for hydraulic / pneumatic Fixures)

- Pressure source
  - Hydraulic  P/T     A/B
  - Pneumatic  P/T     A/B
- Number of ports\_Each Pallet
  - 1pair(2-pt1/4" port)\_each pallet
  - 2pair(4-pt1/4" port)\_each pallet
  - 3pair(6-pt1/4" port)\_each pallet
- Hydraulic power unit
  - Supply scope :  User     DN Solutions
  - Use DN Solutions standard unit 24L / min, 4.9 MPa
  - Special requirement \_\_\_\_\_ L / min, \_\_\_\_\_ MPa

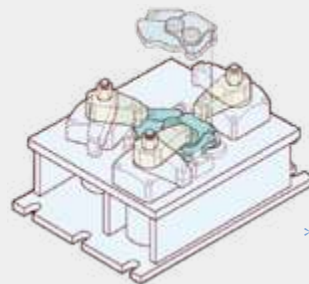

\* Contact DN Solutions for more information

### Hydraulic fixture line

Pneumatic or hydraulic lines supply power from a central power pack to fixtures on each side of the indexing pallet via the center of the table. Various numbers of supply lines and operating pressures are available.

Recommended Rotary Table Size  
VC 430 : Ø170mm (Ø6.7 inch) /  
VC 510 : Ø200mm (Ø7.9 inch)

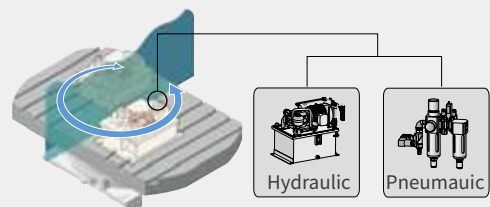

# DN SOLUTIONS FANUC i PLUS

DN Solutions FANUC i Plus is optimized for maximizing customer productivity and convenience.

## 15 inch screen + new operation panel

DN Solutions FANUC i Plus' operation panel enhances operating convenience by incorporating common-design buttons and layout, and features the Qwerty keyboard for fast and easy operation.

### DN Solutions FANUC i Plus

- 15 inch color display
- Intuitive and user-friendly design

### USB & PCMCIA card

### QWERTY keyboard

- EZ-guide i standard
- Ergonomic operator panel
- 2MB Memory
- Hot key



### iHMI touchscreen option

iHMI provides an intuitive interface that uses a touchscreen for quick and easy operation.

### Range of applications

Providing various applications related to planning, machining, improvement and utility, for customer convenience.

## NUMERIC CONTROL SPECIFICATIONS

# FANUC

Item	Specifications	DN Solutions FANUC i (0i PLUS) VC430/VC510
Controlled axis	Controlled axes	3 (X,Y,Z)
	Simultaneously controlled axes	4 axes
	Additional controlled Axis	Add 1 Axis (5th Axis)
Data input/output	Fast data server	○
	Memory card input/output	●
	USB memory input/output	●
	Large capacity memory(2GB)*2	Available Option only with 15" Touch LCD (iHMI Only) *2)
Interface function	Embedded Ethernet	●
	Fast Ethernet	○
	Enhanced Embedded Ethernet function	●
Operation	DNC operation	Included in RS232C interface.
	DNC operation with memory card	●
Program input	Workpiece coordinate system	G52 - G59
	Addition of workpiece coordinate system	G54.1 P1 X 48 (48 pairs)
	Tool number command	T4 digits
	Tilted working plane indexing command	G68.2 TWP
Feed function	AI contour control I	G5.1 Q_, 40 Blocks
	AI contour control II	G5.1 Q_, 200 Blocks
	AI contour control II	G5.1 Q_, 600 Blocks
	AI contour control II	G5.1 Q_, 1000 Blocks *1)
	High smooth TCP	X
Operation guidance function	EZ Guidei (Conversational Programming Solution)	●
	iHMI with Machining Cycle	Only with 15" Touch LCD standard *2)
Setting and display	EZ Operation package	●
	CNC screen dual display function	●
Network	FANUC MTConnect	⊕
	FANUC OPC UA	⊕
Others	Display unit	10.4" color LCD
		15" color LCD
		15" color LCD with Touch Panel
	Part program storage size & Number of registerable programs	640M(256KB)_ 500 programs
		1280M(512KB)_ 1000 programs
		2560M(1MB)_ 1000 programs
		5120M(2MB)_ 1000 programs
		10240M(4MB)_ 1000 programs
		20480M(8MB)_ 1000 programs
		2560M(1MB)_ 2000 programs
		5120M(2MB)_ 4000 programs
		10240M(4MB)_ 4000 programs
		20480M(8MB)_ 4000 programs

\*1) The number of look-ahead blocks may be changed or limited depending on the peripheral device or the configuration of the internal NC system.

\*2) Available Option only with FANUC i plus iHMI

● Standard ○ Optional X N/A ⊕ Available  
Network: FANUC MT Connect and FANUC OPC UA available.

# EZ WORK

The software developed by DN Solutions's own technology provides numerous functions designed for convenient operation.

## EZ work

The EZ work package delivers speed and efficiency. This menu-driven innovation not only helps customers reduce setup times, but also simplifies common tasks and procedures, reducing the potential for errors. EZ work reduces operating time, protects machinery, enhances quality and speeds up maintenance interventions.



### Thermal Compensation

A function to maintain high-precision machining quality by analyzing and correcting the amount of thermal displacement of a structure through a temperature sensor



### M/G-Code List

Functional description of M code and G code



### Tool Management

Function to manage tool information [Tool information / Tool No. / Tool condition (normal, large diameter, worn / damaged, used for the rst time, manual) / Tool name]



### Operation Rate

Machine operation history management function by date based on load



### Adaptive Feed Control

Function to control feedrate so that the cutting can be carried out at a constant load



### Spindle Warm Up

A function that assists spindle warm-up for spindle life when the spindle has not been used for a certain period of time



### ATC Recovery

Function to view detailed info with recommended actions and to perform step-by-step operation manually (when an alarm is triggered during an ATC operation)



### Addition of Optional Block Skip

In addition to the OPTIONAL BLOCK SKIP of the operation panel, the function to skip a specific block selected in the machining program

# POWER | TORQUE

VC 430 / VC 510

## High speed spindle

Max. spindle speed : **10000** r/min

Spindle motor power: **18.5 / 15** kW  
24.8 / 20.1 Hp

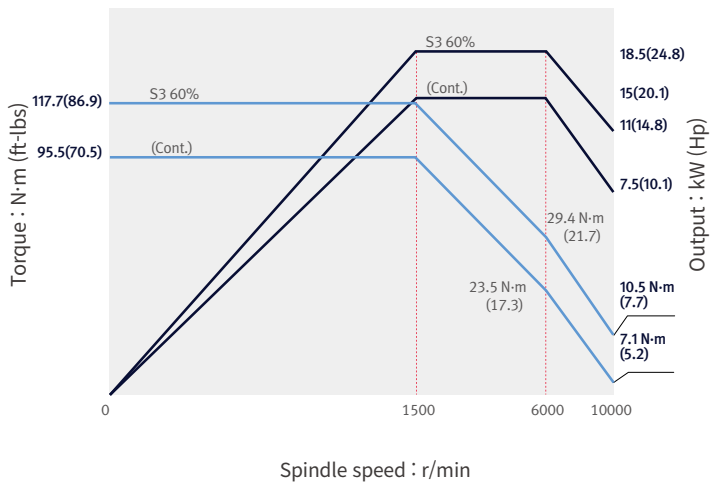

Max. spindle speed : **12000** r/min

Spindle motor power: **18.5 / 15** kW **option**  
24.8 / 20.1 Hp

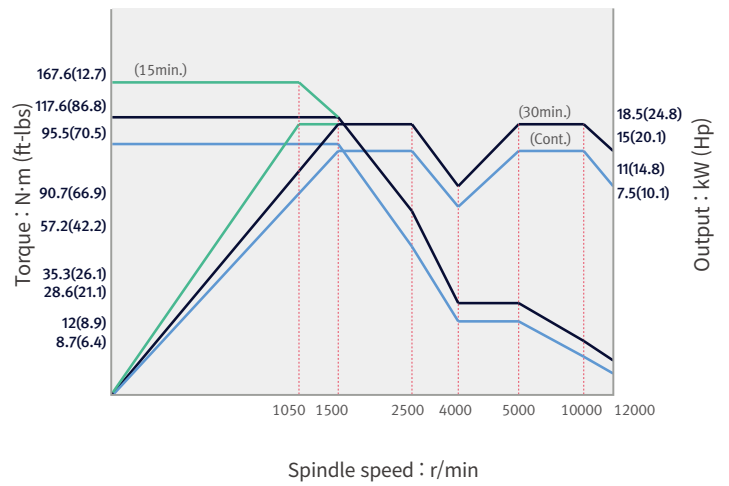

## High torque spindle

Max. spindle speed : **6000** r/min

Spindle motor power: **15 / 11** kW **option**  
20.1 / 14.8 Hp  
(Only VC 510)

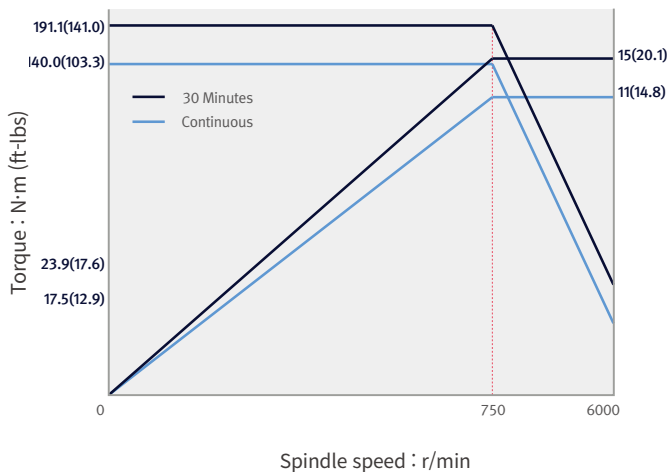

Max. spindle speed : **14000** r/min

Spindle motor power: **15 / 11** kW **option**  
20.1 / 14.8 Hp

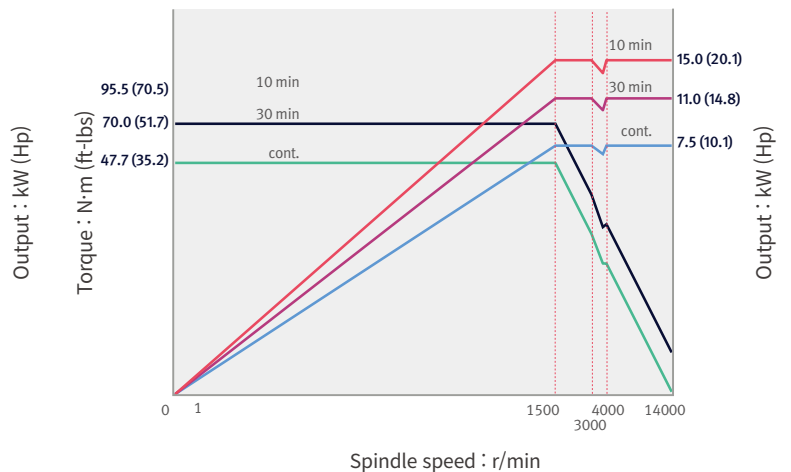

# DIMENSIONS

## VC 430 / VC 510

Units : mm (inch)

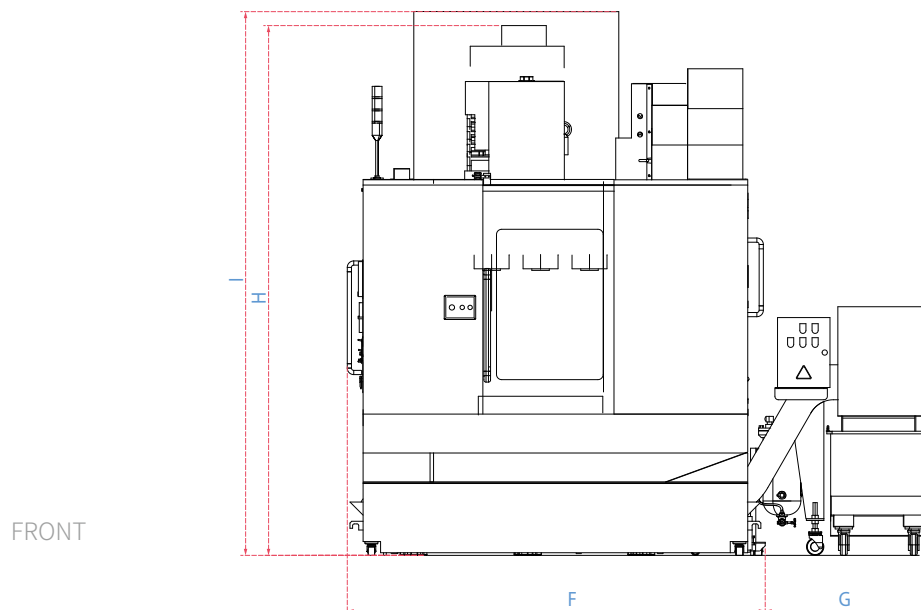
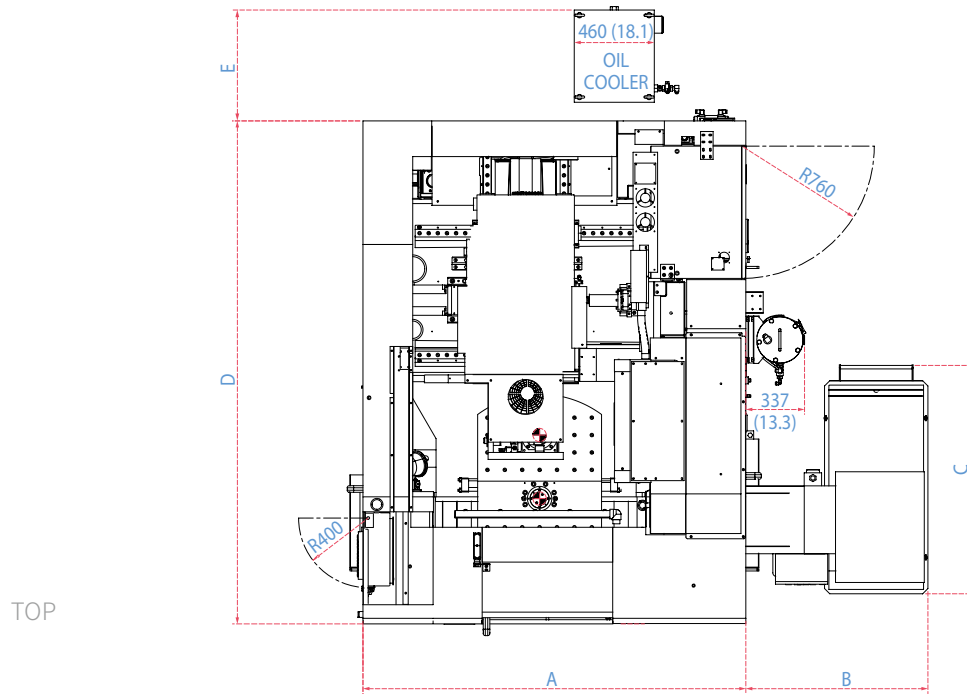

Item	Unit	A	B	C	D	E	F	G	H		I
									Belt type	Direct type	With top cover
VC 430	mm (inch)	2200 (86.6)	1046 (41.2)	1312 (51.7)	2890 (113.8)	637 (25.1)	2391 (94.1)	946 (37.2)	2738 (107.8)	3030 (119.3)	3110 (122.4)
VC 510		2580 (101.6)	1100 (43.3)		3260 (128.3)	590 (23.2)	2580 (101.6)	1100 (43.3)	2830 (111.4)	3130 (123.2)	3250 (128.0)

\* Some peripheral equipment can be placed in other places

# TOOL SHANK

## BT

Units : mm (inch)

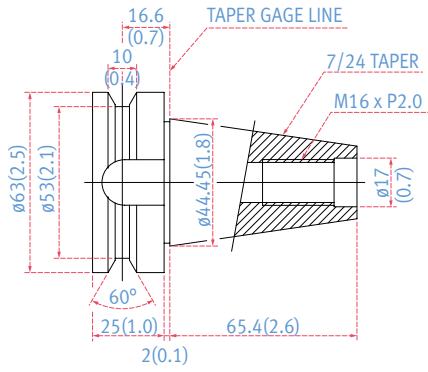

MAS403 BT 40

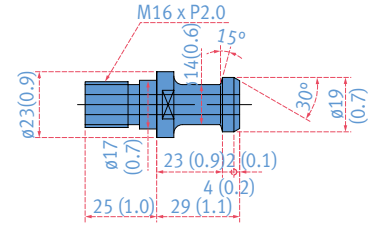
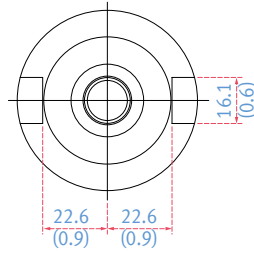

NiKKEN PS-806  
(with TSC)

## CAT option

Units : mm (inch)

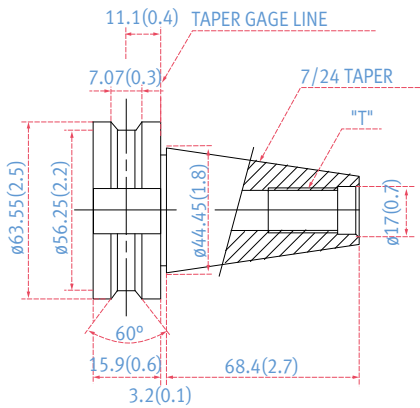

CAT 40

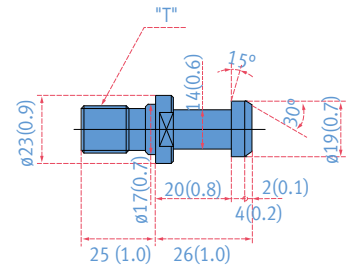
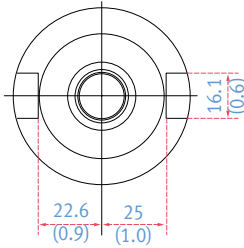

DIN 69872#40  
(with TSC)

## DIN option

Units : mm (inch)

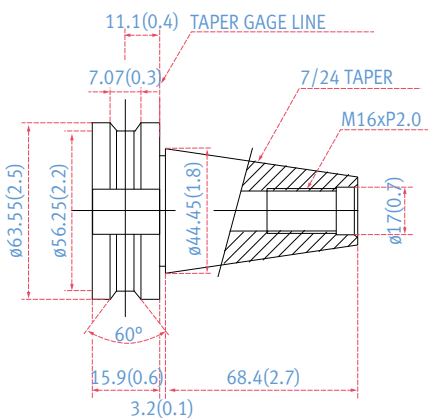

DIN 69871-A40

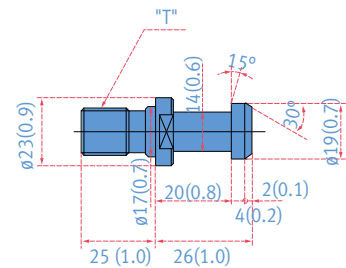
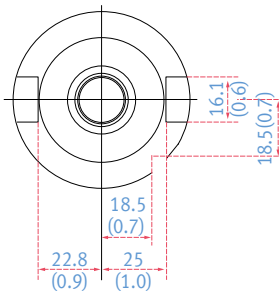

DIN 69872#40  
(with TSC)

# PALLET DIMENSIONS

## VC 430

Units : mm (inch)

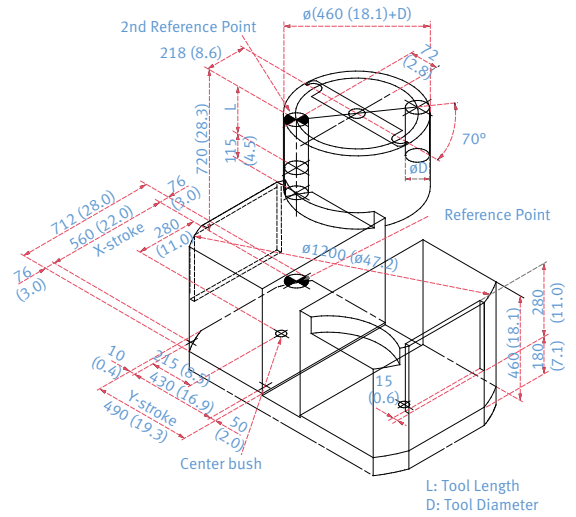
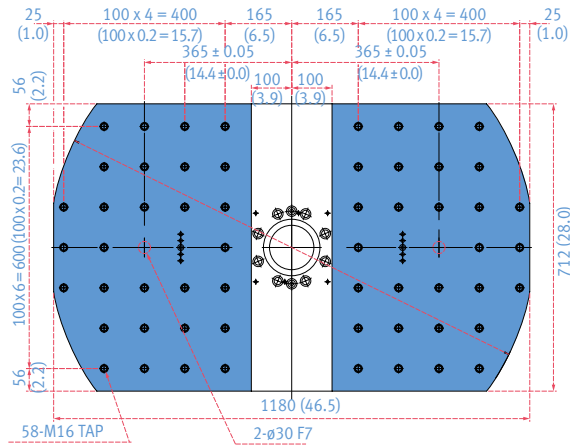

\* If the size of the workpiece is larger than the indicated limit, it may collide with the column, ATC, splash guard, etc.

## VC 510

Units : mm (inch)

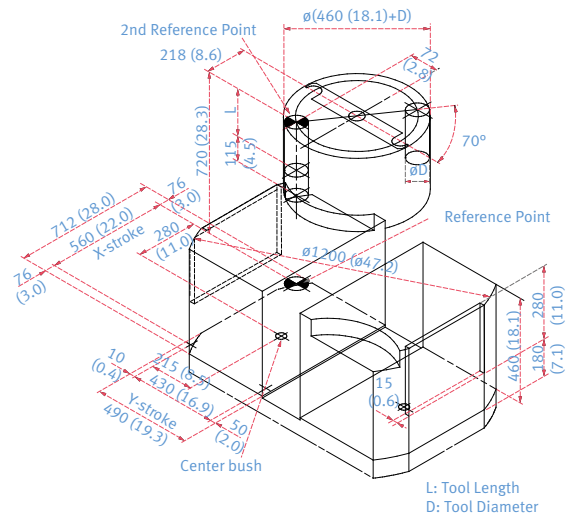
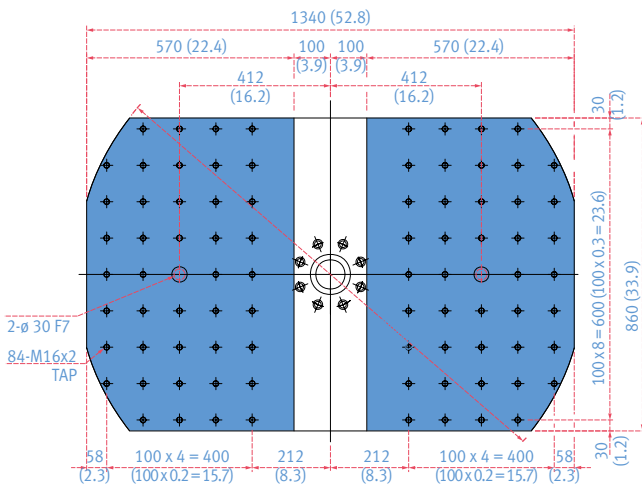

\* If the size of the workpiece is larger than the indicated limit, it may collide with the column, ATC, splash guard, etc.

# MACHINE SPECIFICATIONS

Features		Unit	VC 430	VC 510
Travels	X-axis	mm (inch)	560 (22.0)	762 (30.0)
	Y-axis	mm (inch)	430 (16.9)	516 (20.3)
	Z-axis	mm (inch)	570 (22.4)	
	Distance from spindle nose to table top	mm (inch)	150 (5.9) ~ 720 (28.3)	210 (8.3) ~ 780 (30.7)
	Distance from spindle center to column guideway	mm (inch)	495 (19.5)	530 (20.9)
Travels	X-axis	mm (inch)	560 (22.0)	762 (30.0)
	Y-axis	mm (inch)	430 (16.9)	516 (20.3)
	Z-axis	mm (inch)	570 (22.4)	
	Distance from spindle nose to table top	mm (inch)	150 (5.9) ~ 720 (28.3)	210 (8.3) ~ 780 (30.7)
	Distance from spindle center to column guideway	mm (inch)	495 (19.5)	530 (20.9)
Feedrate	Rapid traverse rate (X / Y / Z)	m/min (ipm)	40 / 40 / 36 (1574.8 / 1574.8 / 1417.3)	40 / 40 / 32 (1574.8 / 1574.8 / 1259.8)
	Cutting feedrate	mm/min (ipm)	18000 (708.7)	16000 (629.9)
Pallet	Pallet size	mm(inch)	2-712 x 490 (2-28.0 x 19.3)	2-860 x 570 (2-33.9 x 22.4 inch)
	Pallet loading capacity	kg (lb)	2-300 (2-661.4)	2-350 (2-771.6)
	Max. workpiece height	mm (inch)	460 <sup>(1)</sup> (18.1)	520 <sup>(1)</sup> (20.5)
	Pallet surface	-	2-29-M16 x P2.0	42-M16 x P2.0 Taper
Spindle	Max. spindle speed	r/min	10000 {12000, 14000}*	10000 {6000, 12000, 14000}*
	Spindle taper	-	ISO #40 7/24 Taper	
	Max. spindle torque	N·m(ft-lbs)	117.7 {167.6}* (86.9 {123.7})	117.7 {191.1, 167.6}*(86.9 {141.0, 123.7})
Automatic tool changer	Type of tool shank	-	MAS403 BT40	
	Tool storage capacity	ea	30 {40}*	
	Max. tool diameter (without adjacent tools)	mm (inch)	80 {76}* (125) (3.1 {3.0} (4.9))	
	Max. tool length	mm (inch)	220 <sup>(2)</sup> (8.7) / 300 <sup>(3)</sup> (11.8)	
	Max. tool weight	mm (inch)	8 (0.3)	
	Max. tool moment	N·m(ft-lbs)	5.88 (4.3)	
	Tool change time (tool-to-tool)	s	60Hz {50Hz}* : 1.3 {1.6}*	
Automatic pallet changer	Number of pallet	ea	2	
	Pallet change time	s	5	5.5
Motor	Spindle motor	kW (Hp)	18.5 / 15 (24.8 / 20.1)	18.5 / 15 (24.8 / 20.1) (10000, 12000 r/min) 15 / 11(20.1 / 14.8) (6000 r/min)
	Feed motor (X / Y / Z)	kW (Hp)	4.0 / 4.0 / 4.0 (5.4 / 5.4 / 5.4)	
Power source	Electric power supply (rated capacity)	kVA	40.2 (10000 r/min) 35.1 (12000 r/min)	39.4 (6000 r/min) 40.2 (10000 r/min) 35.1 (12000 r/min)
	Compressed air supply	MPa	0.54	
Tank capacity	Coolant tank capacity	L (gallon)	300 (79.3)	420 (111.0)
	Lubrication tank capacity (available)	L (gallon)	2 (0.5)	
Machine Dimensions	Height	mm (inch)	3030 (119.3)	3130 (123.2)
	Length	mm (inch)	2890 (113.8)	3260 (128.3)
	Width	mm (inch)	2200 (86.6)	3130 (123.2)
	Weight	kg (lb)	7800 (17195.8)	9200 (20282.2)
Control	NC system		DN Solutions Fanuc i Plus	

\* { } : Optional

(1) This value is the maximum for the height of rectangular without interference of ATC operating.

(2) Available with pallet change.

(3) Available in tool magazine.



# WHY DN SOLUTIONS

The DN Solutions promise, MACHINE GREATNESS, has two important meanings. The first is simple: DN Solutions makes great machines. The second is a challenge to our end-users. With a product line that is this comprehensive, accurate and reliable, we equip our customers to machine greatness. The big question: *Why should you choose DN Solutions over other options?*

Here's why...



**MACHINE  
GREATNESS™**



WHAT YOU MAKE AND HOW YOU MAKE IT MATTERS—SO MAKE IT  
GREAT WITH DN SOLUTIONS.

## UNBEATABLE MACHINES

You won't find a more comprehensive range or a better combination of value, performance and reliability anywhere else.

## ROBUST PRODUCT LINE

We offer an impressive range of machine models and hundreds of configurations. Whatever your machining needs and requirements, there's a DN Solutions for you.

## READILY AVAILABLE - ANYWHERE IN THE WORLD

Machining centres (including 5-axis machines), lathes, multi-tasking turning centres and mill-turn machines, and horizontal borers with best-in-class specifications are all available...ready to install.

## EXPERT SERVICE

Our dedicated, experienced and knowledgeable team is totally committed to improving your productivity, growth and success.

# CUSTOMER SUPPORT AND SERVICES

**We're there for you whenever you need us.**

We help our customers operate at maximum efficiency by providing them with a range of tried, tested and trusted services - from pre-sales consultancy to post-sales support.



## FIELD SERVICES

- On-site service
- Machine installation and testing
- Scheduled preventive maintenance
- Machine repair service

## PARTS SUPPLY

- Supplying a wide range of original DN Solutions spare parts
- Parts repair service



## TRAINING

- Programming, machine setup and operation
- Electrical and mechanical maintenance
- Applications engineering

## TECHNICAL SUPPORT

- Supports machining methods and technology
- Responds to technical queries
- Provides technical consultancy

# RESPONDING TO CUSTOMERS ANYTIME, ANYWHERE

## DN Solutions Global Network

DN Solutions provides systems-based professional support services, before and after the machine tool sale, by responding quickly and efficiently to customers. By supplying spare parts, product training, field service and technical support, we provide the expert care, attention and assistance our customers expect from a market leader.



Global sales and service support network

<b>4</b>	<b>Corporations</b>
<b>156</b>	<b>Dealer networks</b>
<b>51</b>	<b>Technical centers</b> Technical Center, Sales Support, Service Support, Parts Support
<b>200</b>	<b>Service posts</b>
<b>3</b>	<b>Factories</b>





[dn-solutions.com](http://dn-solutions.com)

**Head Office**

22F T Tower, 30, Sowol-ro 2-gil  
Jung-gu, Seoul, Korea, 04637

Tel: +82-2-6972-0370/0350  
Fax: +82-2-6972-0400

**DN Solutions America**

19A Chapin Road, Pine Brook  
New Jersey 07058, United States

Tel: +1-973-618-2500  
Fax: +1-973-618-2501

**DN Solutions Europe**

Emdener Strasse 24, D-41540  
Dormagen, Germany

Tel: +49-2133-5067-100  
Fax: +49-2133-5067-111

**DN Solutions India**

No.82, Jakkuar Village  
Yelahanka Hobli, Bangalore-560064

Tel: + 91-80-2205-6900  
E-mail: [india@dncompany.com](mailto:india@dncompany.com)

**DN Solutions China**

Room 101,201,301, Building 39 Xinzhuan  
Highway No.258 Songjiang District  
China Shanghai (201612)

Tel: +86 21-5445-1155  
Fax: +86 21-6405-1472

**Sales inquiry**

[sales@dncompany.com](mailto:sales@dncompany.com)

\* For more details, please contact DN Solutions.

\* Specifications and information contained within this catalogue may be changed without prior notice.