

TWIN-SPINDLE, TWIN-TURRET TURNING CENTERS WITH Y-AXES

PUMA TT 2500

PUMA TT 2500MS/SY

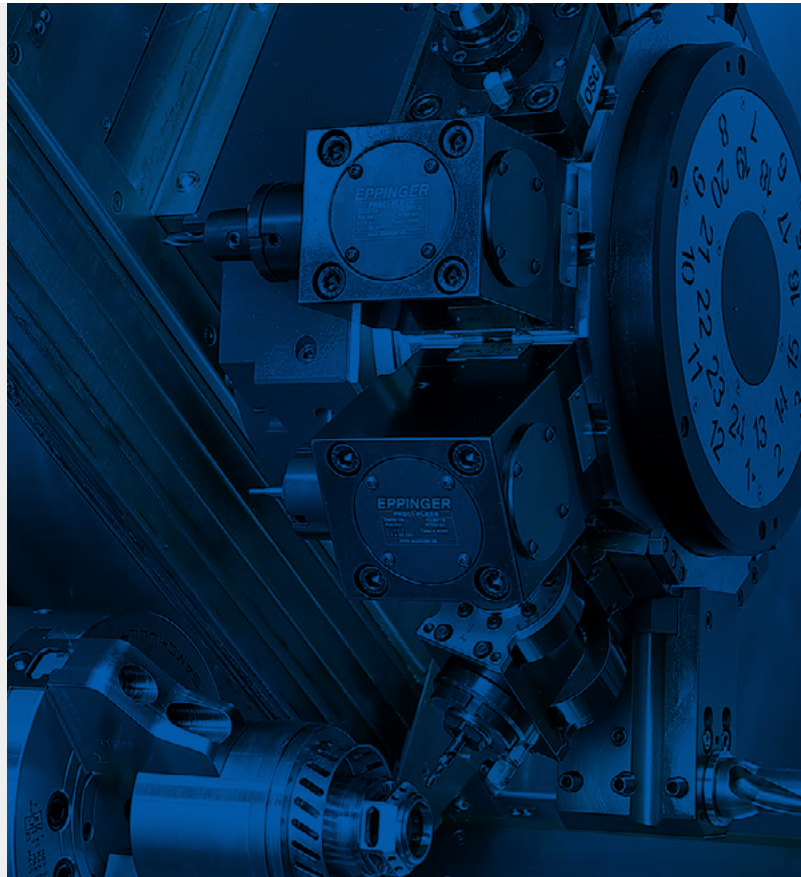

PUMA TT 2500

High performance turning center featuring first & second spindle that have the same power and capacity, with upper & lower turrets on the grounded box type bed. Simultaneous machining on two faces with both spindles and turrets and virtual realization of Y-axis function will bring you double productivity. The compact PUMA TT is packed with one-setup efficiency. Thanks to its 24 tool positions in the upper and lower turrets, you'll complete complicated parts that require plenty of tools in just one setup.

CONTENTS

Product Overview

Basic Information

- 04 Basic Structure
- 05 Flexible Machining
- 06 Spindle
- 07 Turrets

Detailed Information

- 08 Standard / Optional Specifications
- 09 Peripheral Equipment
- 11 FANUC i PLUS
- 13 SINUMERIK ONE
- 14 Power | Torque
- 15 External Dimensions
- 16 Tooling System
- 17 Tool Interference Diagram
- 18 Working Range Diagram
- 19 Machine Specifications



EXCELLENT RIGIDITY AND POWER



The left and right spindles and the upper and lower turrets operate independently to double the machine's productivity.

DOUBLED PRODUCTIVITY



All guide ways are wide wraparound rectangular type for unsurpassed long term rigidity and accuracy.

ADVANCED AUTOMATION

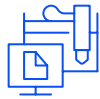

The left and right spindles are equipped with independent parts catcher and unloading/conveyor systems for fully-automated operation.



BASIC STRUCTURE

Machine construction

Perfect integration of multi-process and high productivity are achieved by Left & right spindle of the same power and capacity, with upper & lower turrets on the grounded box type bed.

Achievement of PUMA TT machines

Continuous process accuracy, Shorten setting time, Optimal distribution of cycle and Automated works.

Outstanding rigidity for high feedrates

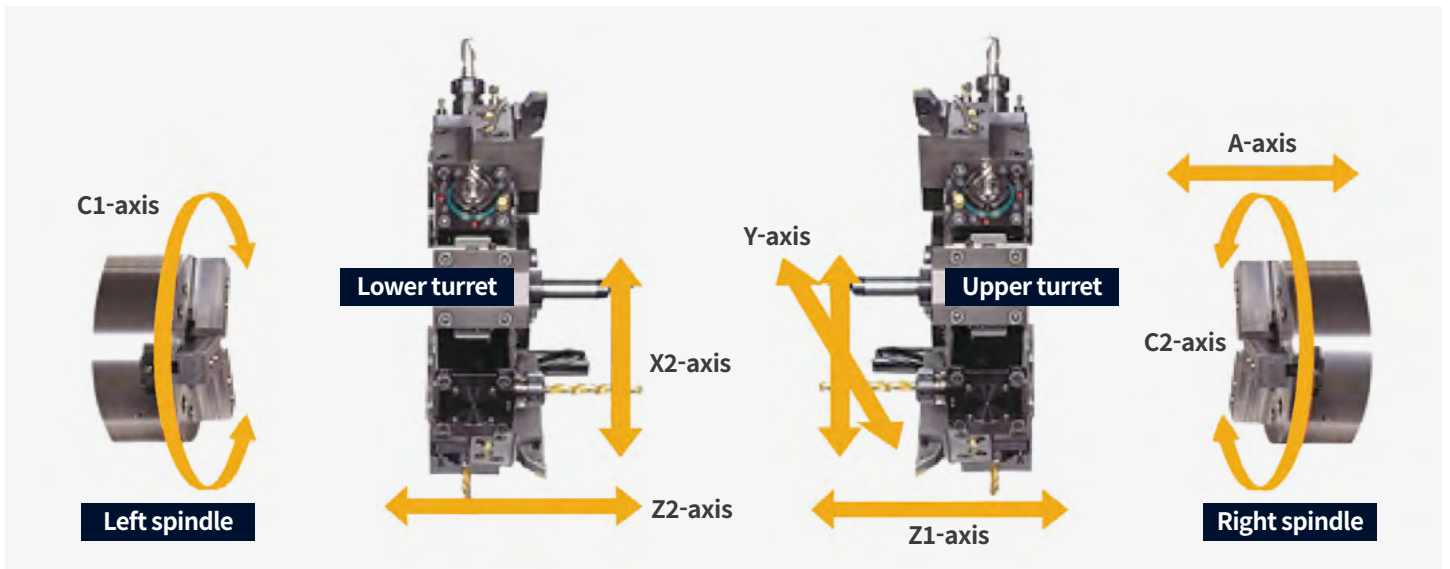
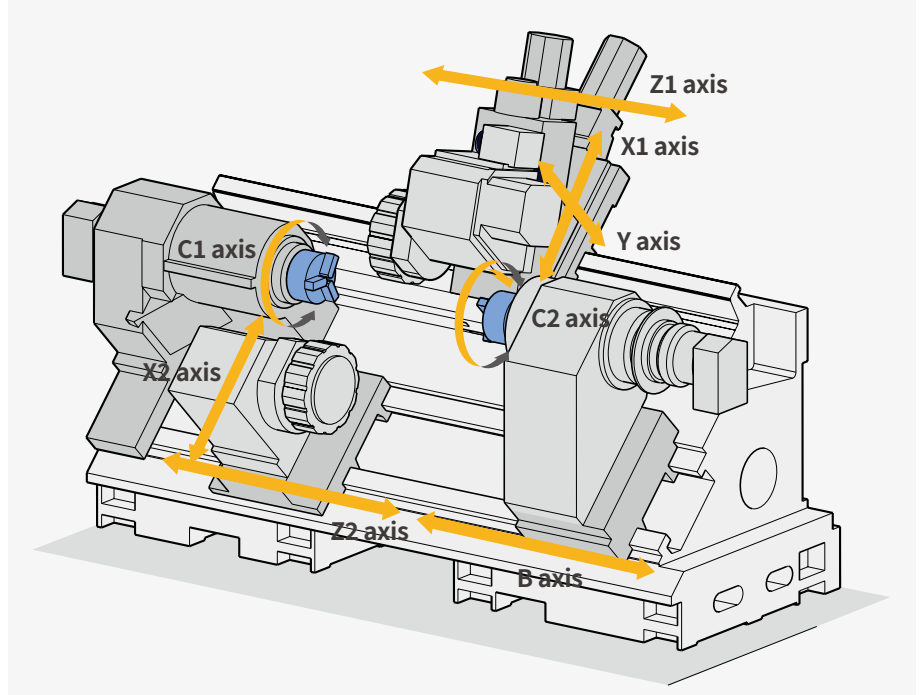

Rapid traverse

X-axis	Z-axis
20 m/min (787.4 ipm)	24 m/min (944.9 ipm)

Travel

X1-axis (Upper turret)	Z1-axis (Upper turret)	A-axis
255 mm (10.0 inch)	800 mm (31.5 inch)	810 mm (31.9 inch)
X2-axis (Lower turret)	Z2-axis (Lower turret)	
190 mm (7.5 inch)	900 mm (35.4 inch)	

FLEXIBLE MACHINING

PUMA TT2500SY A versatile performer

A : Max. turning dia. (on Upper turret)

390 mm (15.4 inch)

A : Max. turning dia. (on Lower turret)

300 mm (11.8 inch)

B : Max. turning length

350 mm (13.8 inch)

C : Max. bar working dia. (Left spindle)

81 mm (3.2 inch)

C : Max. bar working dia.(Right spindle)

81 mm (3.2 inch)

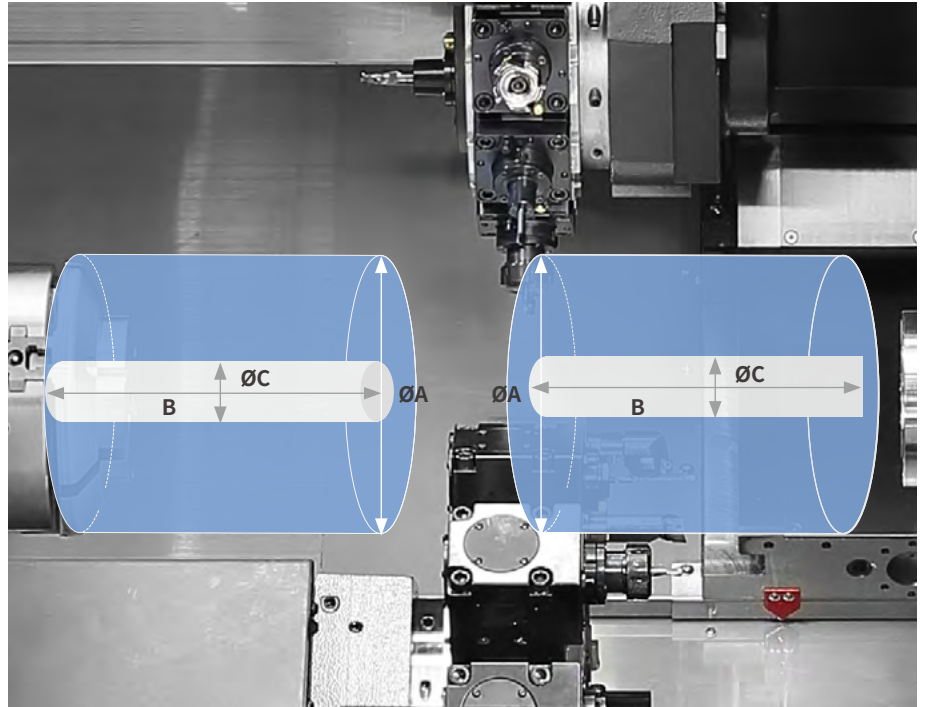

Y-axis milling

A wide variety of multi-axis milling cycles can be achieved using the Y-axis.

Y-axis working range

By simultaneous X-Y-Z-axis feed control and C-axis function to guide precise circular orientation of spindle, Y/X axes circular interpolation simplifies the machining of complex shapes in faster cycle time.

Y-axis travel

120(±60) mm (4.7 (±2.4) inch)

Y-axis rapid

7.5 m/min (295.3 ipm)

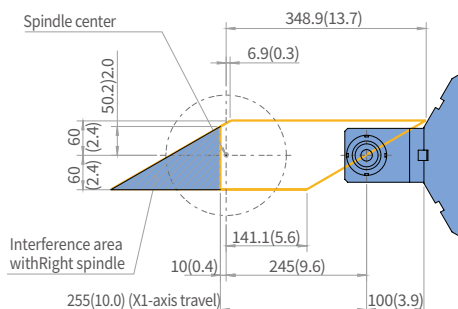

Angular milling unit moving area

Groove finish cutting using the Y-axis

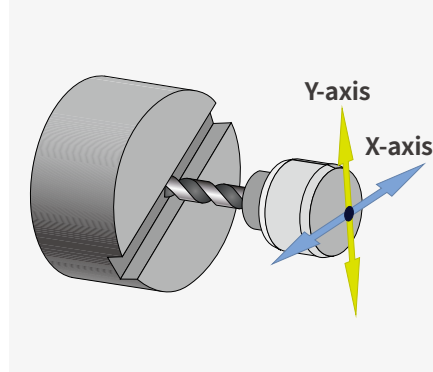

Multi-face cutting

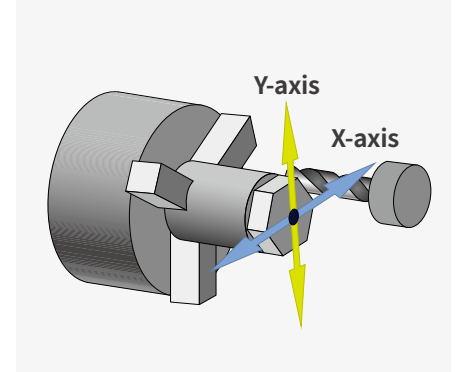

Milling in an eccentric position

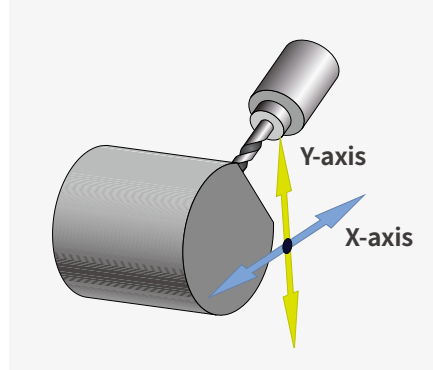

Y & X-axis circular interpolation

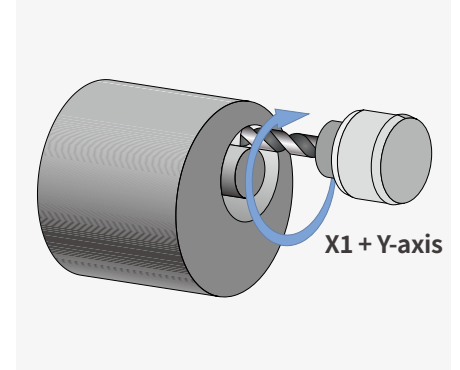

SPINDLE

High-speed and high-power spindle delivers impressive productivity.

Built-in design

Both left and right spindle have built-in motor spindles that wholly covered with oil cooling system to ensure remarkable range of applications from heavy duty cutting with high power at low speed to fine to finish cutting at high speed and optimize thermal displacement. Both Left and Right spindle are designed to minimize maleffects of thermal distortion which can hit continuous machining precision seriously. Especially the same capacity of both spindles improves productivity remarkably of single machine.

Max. power (30 min)

26/22 kW (34.9/29.5 Hp)

Max. spindle speed (10inch)

4000 r/min

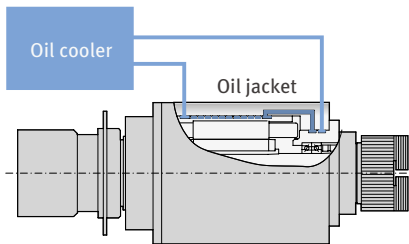

Oil cooling unit for spindles

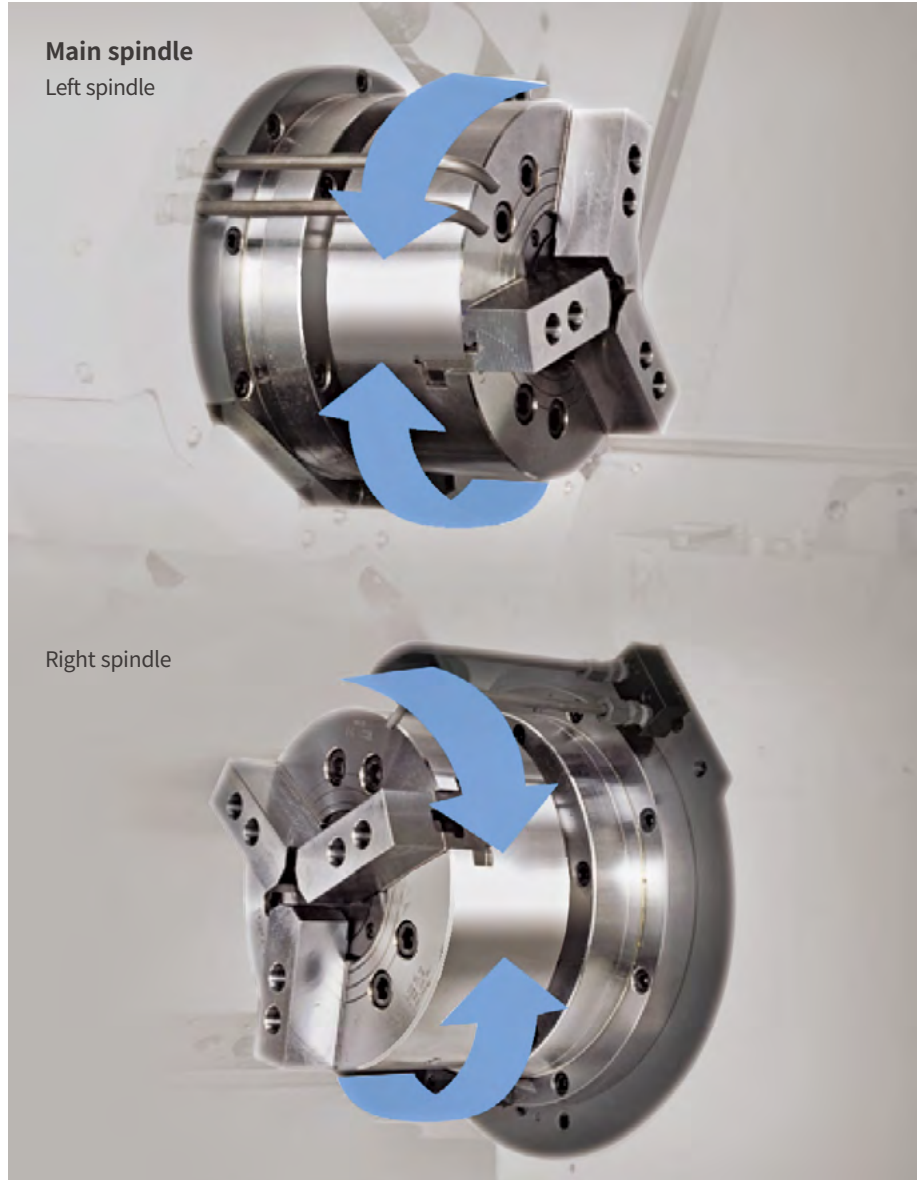

C-axis accuracy

The positioning and repeatability of the C-axis has been enhanced.

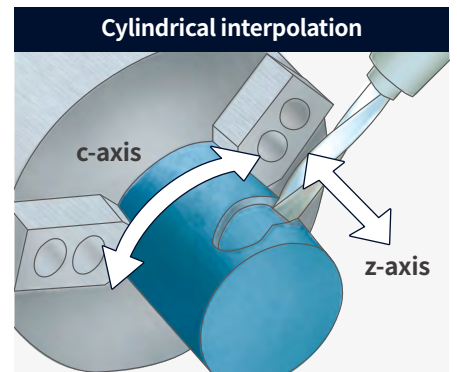
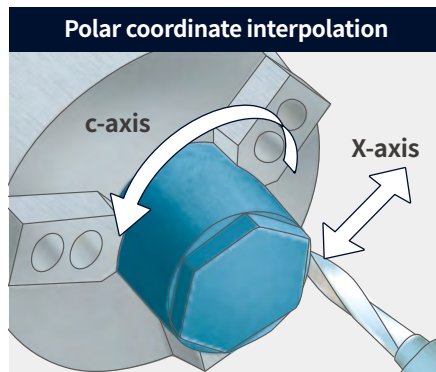

TURRETS

Featuring stronger and faster turrets; upgraded servo motors for faster and more accurate tool rotation; and a stabilized structure for higher productivity and heavier-cutting capabilities.

Turret with upgraded speed and rigidity

Total of 24 tool stations upper and lower turret(BMT65P) make it possible to complete complicated parts requiring many tools in just one set-up. Reliable servo driven turrets reduce the total cycle time required to machine parts.

Index time (1-station swivel)

0.20 s

No. of tool stations (Upper+Lower turret)

24 (12+12) st

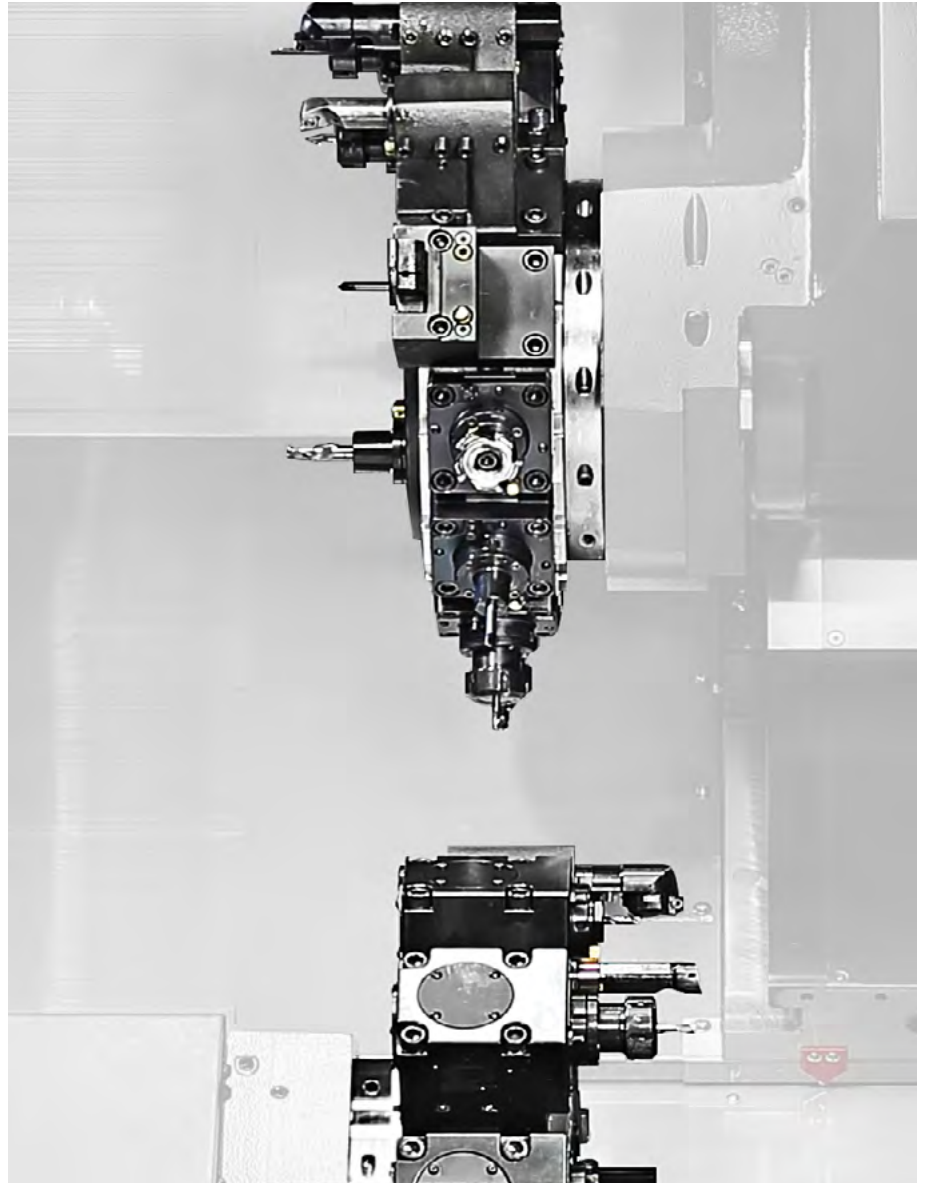

Radial BMT65P

The turret features BMT65P style tooling in which the toolholders are mounted directly to the turret's periphery using 4 large bolts.

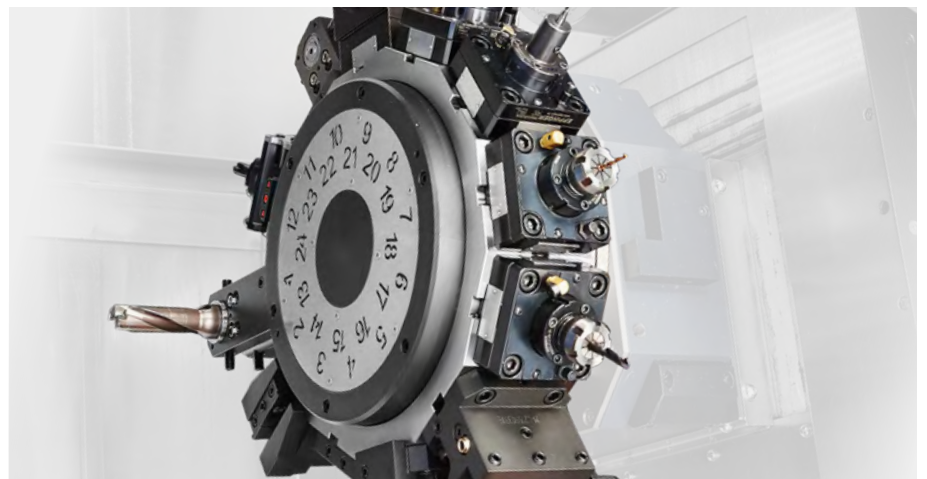
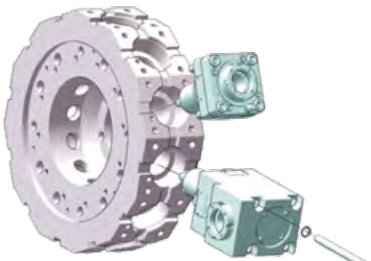

STANDARD | OPTIONAL SPECIFICATIONS

A range of options is available to suit individual requirements.

Description	Features	PUMA TT2500series
Chuck (Left / Right)	Plunger stroke: MH210 (19)/Cylinder stroke: SD-18582 (30)	●
	None	○
Jaws (Left / Right)	Soft Jaws	●
	Hardened & ground hard Jaws	○
Chucking option	Dual pressure chucking	○
	Chuck clamp confirmation	○
Tailstock	Tail center for turret	○
Coolant pump	1.5 bar	●
	4.5 / 7 / 10 / 14.5 / 20 / 70 bar	○
Coolant options	Oil skimmer	○
	Water soluble Coolant Chiller*	○
	Coolant pressure switch	○
	Cooling flow switch	○
	High coolant Interface	○
	Chuck coolant (Left / Right)	○
	Through spindle coolant(T.S.C) for spindle (Left / Right)	○
	Coolant gun	○
Chip processing options	Chip conveyor_Side type	○
	Chip conveyor_Rear type	○
	Chip bucket	○
	Air blow (Left / Right)	●
	Mist collector	○
Measurement & automation	Tool setter (Auto)	○
	Parts catcher and box	X
	Parts unloader and conveyor	○
	Work ejector	○
	Auto door	○
	Cut-off confirmation	○
	Work / Tool counter	○
	Robot interface (PMC I/O, Profibus)	○
Optional devices	Bar feeder interface	○
	Tool Load Monitoring	○
	Linear scale (X1, X2)	○
	Signal tower	○
	Air gun	○
	Air conditioner for electric cabinet	○
	Light for electric cabinet	○
	Extra M-code (4ea)	○
	Auto power off	○
	Quick change tooling(CAPTO)	○
Customized special option	Coolant level switch : Sensing level - Low	○
	Parts unloader and conveyor_Grippertype	○
	Automatic top door	○
	Coolant gun	○
	Coolant chiller	○
	Chip conveyer_drum filter type	○
	Shower coolant	○
	Air limit sensing on chuck_Preparation	○
	Rotary type window wiper_Eletrical	○
	TSCfor Main/Left spindle	○
	TSC for Sub/Right spindle	○
	TSA for Main/Left spindle	○
	TSA for Sub/Right spindle	○
	Work & tool counter	○
	Tool setter extension for special chuck	○
	Main/Left spindle air curtain	○
	Sub/Right spindle air curtain	○
	MQL System	○
Chuck Pressure Switch	○	

*Please contact your DN Solutions representative for detailed machine information.

* Technical consultation is mandatory for the chilling of non-water soluble coolant

● Standard ○ Optional X N/A

 Fire Safety Precautions | There is a high risk of fire when using non-water-soluble cutting fluids, processing flammable materials, neglecting the controlled and careful use of coolants and modifying the machine without the consent of the manufacturer. Always check the SAFETY GUIDELINES carefully before using the machine.

PERIPHERAL EQUIPMENT

Ergonomic design

Swivel type operator panel

Operator oriented design with 90°swivel



Safety window on front door

Viewing window is designed and was tested under heavy condition to protect operator against possible dangers during real cutting thanks to its shock absorbing laminated glass and double panel construction. The window without grating also provides a clear view of the machine inside.

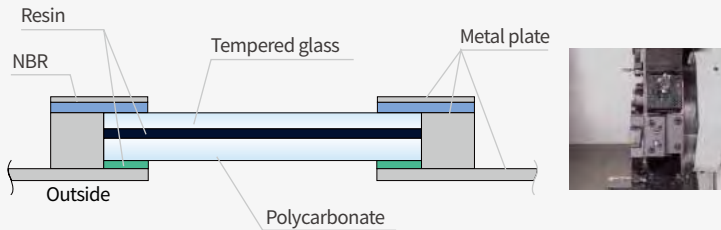

High maintainability

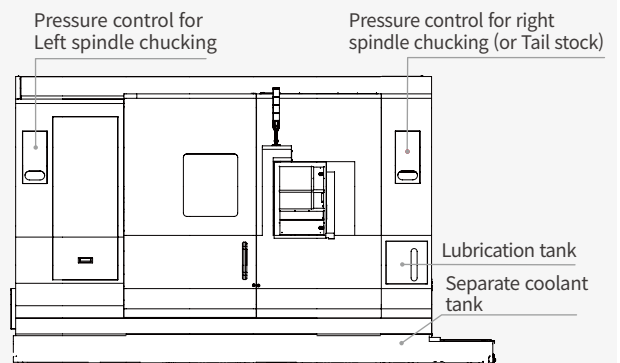

Eco-friendly design

Oil skimmer OPTION

Another suggestion to prolong the life time of the coolant water. A belt-driven type oil skimmer picks up and removes waste oil from the coolant tank that is easily drained.

Collection of waste lubrication Oil

Less waste lubrication oil extends the life time of the coolant water and cut down the grime and offensive smell of the machine inside.

No coolant leakage

Rigorously designed, manufactured and tested machine covers do not permit coolant leakage in any condition. The factory always keeps our environment clean.

Coolant chiller (recommended) OPTION

Coolant chiller is highly recommended to prevent temperature rise and minimize thermal deformation, when using a water-insoluble coolant or high-pressure coolant system of which the power is over 1.5 kw.

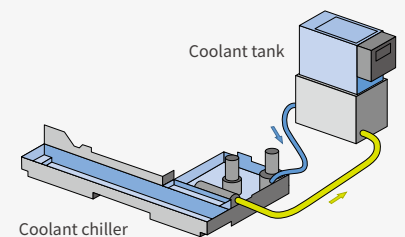

PERIPHERAL EQUIPMENT

Optimal support system of automatic operation OPTION

Parts unloader & conveyor

Parts unloader system built inside the machine can receive workpieces from both spindles. Automated operation is realized perfectly when the system is coupled with bar feeder system.

Max. work diameter	Ø81 mm (3.2 inch)
Max. work length	160 mm (6.3 inch)
Max. work weight	4kg (8.8 lb)

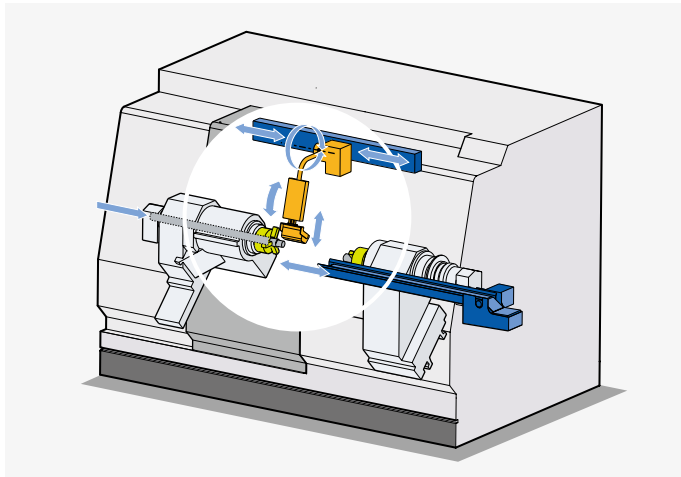

Bar feeder system

Automated bar working is possible by bar feeder system. When parts unloader system is added, its value of use will be in the best.

Max. bar working dia

Ø81 mm (3.2 inch)

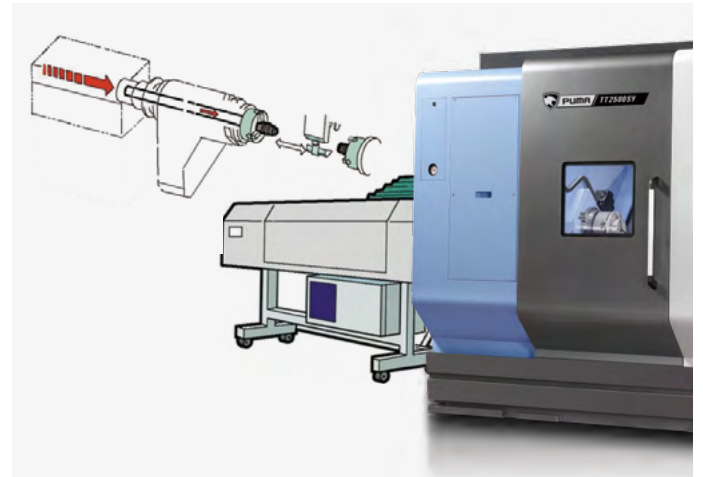

** Depending on the chuck and cylinder spec. used in the machine, the bar working dia. can be reduced.*

Optional equipment

Auto tool setter



Coolant blower



Signal tower



Collet chuck

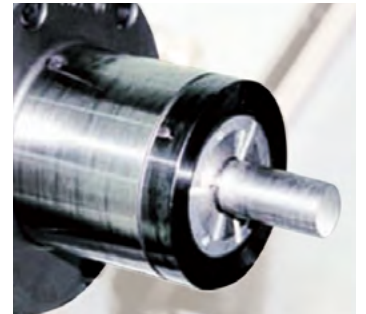

ID/OD special holder (each turret 12ea/tool 24ea)

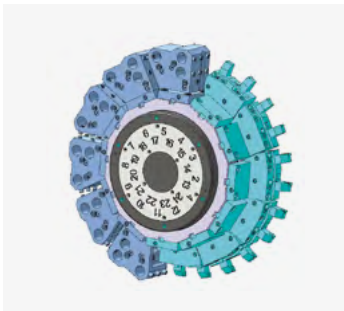

Milling special holder (each turret 12ea/tool 24ea)

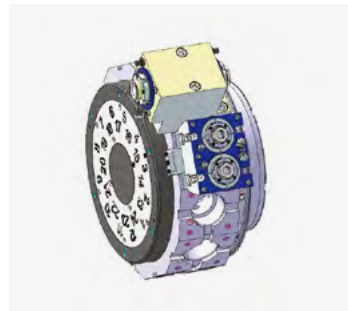

Work ejector

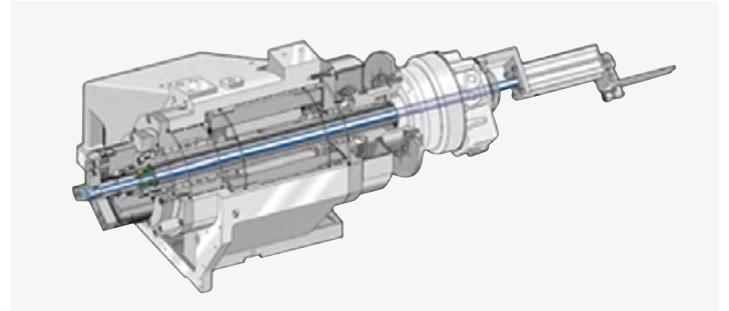

DN SOLUTIONS FANUC i PLUS

DN Solutions Fanuc i Plus maximizes customer productivity and convenience.



15" Screen + New OP

DN Solutions Fanuc i Plus' operation panel enhances operating convenience by incorporating common-design buttons and layout. It features a Qwerty keyboard for fast and easy data input and operation.

DN Solutions Fanuc i Plus

- 15-inch color display
- Intuitive and user-friendly design

USB and PCMCIA card QWERTY keyboard

- EZ-Guide i standard
- Ergonomic operator panel
- 2MB Memory
- Hot keys

iHMI touchscreen OPTION

iHMI provides an intuitive interface that uses a touchscreen for quick and easy operation.

Range of applications

Providing various applications related to planning, machining, improvement and utility, for customer convenience.



Real-time custom macro function OPTION

During operation of the parts unloader of the right spindle, this function allows the lower turret to conduct the cutting operation for the left spindle. This function also further improves the productivity.

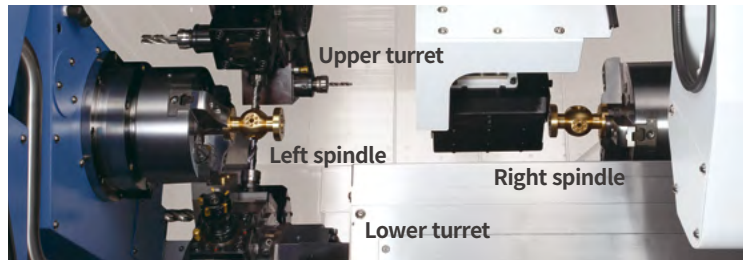

NUMERIC CONTROL SPECIFICATIONS



Division	Item	Specifications	MS	SY
			DN Solutions Fanuc i Plus	DN Solutions Fanuc i Plus
Controlled axis	Controlled axes		7 (X1,Z1,C1, X2,Z2C2,A)	8 (X1,Z1,C1,Y, X2,Z2,C2,A)
	Simultaneously controlled axes		4 axes (each path)	4 axes (each path)
Data input/output	Fast data server		○	○
	Memory card input/output		●	●
	USB memory input/output		●	●
Interface function	Large capacity memory(2GB)	Only with Fanuc i Plus iHMI	○	○
	Embedded ethernet		●	●
	Fast Ethernet		○	○
Operation	Enhanced embedded ethernet function		●	●
	DNC operation	Included in RS232C interface.	●	●
	DNC operation with memory card		●	●
Program input	Workpiece coordinate system	G52 - G59	●	●
Feed function	AI contour control I	G5.1 Q _z , 40 Blocks	●	●
	AI contour control II	G5.1 Q _z , 200 Blocks	○	○
Operation guidance function	EZ Guidei (Conversational programming solution)		●	●
	iHMI with machining cycle	Note *1) Only with 15" touch LCD standard	○ *1)	○ *1)
	Multi path function	Supporting 2 or 3 path machine	●	●
	EZ Operation package		●	●
Setting and display	CNC screen dual display function		●	●
Network	FANUC MTConnect		✳	✳
	FANUC OPC UA		✳	✳
Others	Display unit	15" color LCD	●	●
		15" color LCD with touch panel	○	○
	Part program storage size & Number of registerable programs	1280M(512KB)_1000 programs	X	X
		5120M(2MB)_1000 programs	●	●

DN SOLUTIONS FANUC i PLUS

EZ-Guide i

Using the DN Solutions EZ-Guide i, users can create a cutting program for any desired shape, including patterns, by entering just the dimensions.

Example programming : Cutting shape

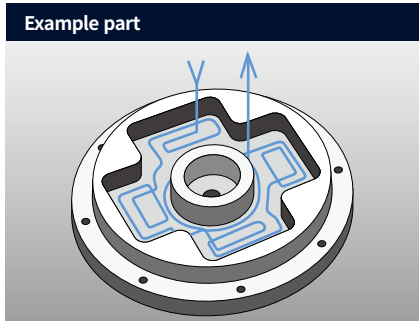
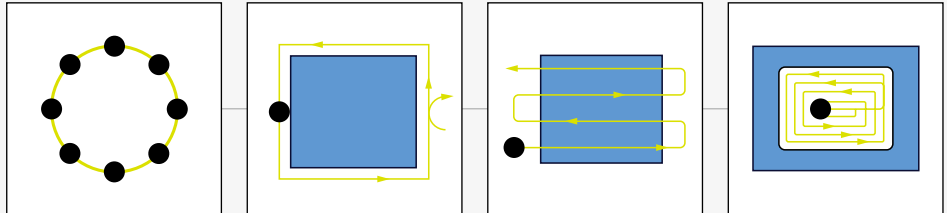

Automatic creation of cutting program

```
O7000 (SAMPLE PROGRAM) ;
...
M3 S1500 ;
G0 X50. Y125. ;
G0 Z30. ;
G1040 T0.5 J3. H0.2 K0.5 ... ;
G1020 H120. V50. U37. W68. ... ;
G0 Z80. ;
M5 ;
```

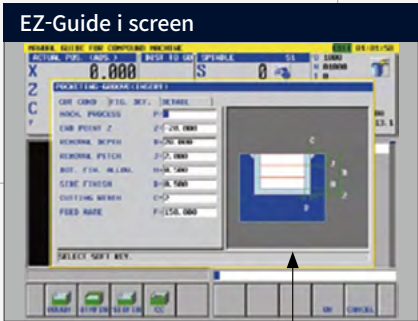

A cutting program is automatically created with the entered values.

Enter the dimensions of the shape

EZ Work

DN Solutions's EZ Work supports the user with functions relating to tool data, error diagnostics, set up and machine monitoring.

Tool monitoring screen



Tool load monitoring function

During cutting operation, abnormal load caused by wear or damage of the tool is detected and an alarm is triggered to prevent further damage.

Parts unloader maintenance and service screen



Convenience of maintenance and service

The condition and service procedures of the sensors are provided for easy maintenance and servicing of major units.

Q-setter Automatic measurement



Convenient set up for peripheral equipment

Helps tool setter guide, work setting, tailstock setting, and other measurement and parameter control to reduce setting-up time and facilitates operation.



Crash avoid check

Set the interference area between turret and sub spindle to avoid collision.



Tool management

CONVENIENT OPERATION

SINUMERIK ONE

21.5 inch display + New OP

Two path programs are displayed simultaneously in the large 21.5-inch screen for enhanced user convenience.

- 21.5-inch display
- 6GB user memory
- USB (standard)
- QWERTY keyboard



Convenient conversational functionality

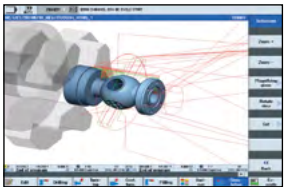

Cutting and operation support function
This function shows a cutting and tool path simulation in real-time.

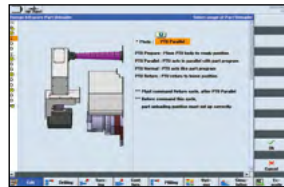

Shop-turn mode
[various]
↓
[attachments]

The automation elements (parts catcher, parts unloader etc.), can be easily controlled via interactive screens.

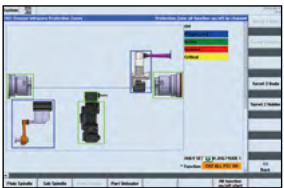

[Custom]
↓
[Protection zones]

Operation safety function
Protection Zone Synchronized Actions checks the interference between the turret and the spindle to prevent collisions caused by operator error.

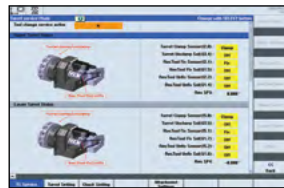

[offset]
↓
[operating parameter]
↓
[TC service]

Maintenance and service convenience function
Maintenance and service of major equipment and peripheral devices, including the timer and parts counter settings can be easily undertaken.

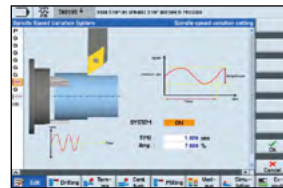

[various]
↓
[attachment]
↓
[DSSV]

Machining accuracy improvement
The NC controls spindle speed at an optimal level for precision threading and turning, making it possible to automatically improve surface roughness.



Before applying the function
After applying the function

NUMERIC CONTROL SPECIFICATIONS

SIEMENS

Division	Item	Specifications	MS		SY	
			S828D	SONE	S828D	SONE
Controlled axis	Controlled axes		X1,Z1,C1,X2,Z2,C2,Z3,C3,C4		X1,Z1,C1,X2,Z2,C2,Z3,C3,C4,Y	
	Simultaneously controlled axes		4 axes	4 axes	4 axes	4 axes
Data input/output	Memory card input/output		X	X	X	X
	USB memory input/output		●	●	●	●
Interface function	Ethernet	(X130)	○	●	○	●
Operation	On network drive	(without EES option, Extcall)	○	●	○	●
	On USB storage medium, e.g. memory stick	(without EES option, Extcall)	●	●	●	●
Program input	Workpiece coordinate system	G54 - G59, G507 - G599	●	●	●	●
	Advanced surface		X	●	X	●
Feed function	Top surface		X	X	X	X
	Look ahead number of block		1	1000	1	1000
Programming & Editing function	3D simulation, finished part		●	●	●	●
	Simultaneous recording		●	●	●	●
	DXF reader for PC integrated in SINUMERIK operate		○	○	○	○
Operation guidance function	Shopturn		●	●	●	●
	EZ operation package		●	●	●	●
Setting and display	Operation via a VNC viewer		●	●	●	●
	MTCConnect		⊕	⊕	⊕	⊕
Network	OPCUA		○	○	○	○
			○	○	○	○
Others	Display unit	15.6" color display with touch screen(SW4.9)	●	○	●	○
		21.5" color display with touch screen(SW4.9)	X	●	X	●
		CNC user memory 10 MB	●	●	●	●
		CNC user memory 100 MB	○	○	○	○
		CNC user memory 6GB	X	○	X	○
		CNC user memory 40GB (with PCU or IPC)	X	○	X	○
	Part program storage size	CNC user memory without limit(Execution from external storage devices)(EES / Using by USB or Network)	○	○	○	○
		HMI user memory for CNC part program 6GB	X	●	X	●

POWER | TORQUE

PUMA TT2500MS/SY

Max. spindle speed

4000 r/min

Max. spindle power

26 kW (34.9 Hp)

Max. Spindle torque

521 N·m (384.3 ft-lbs)

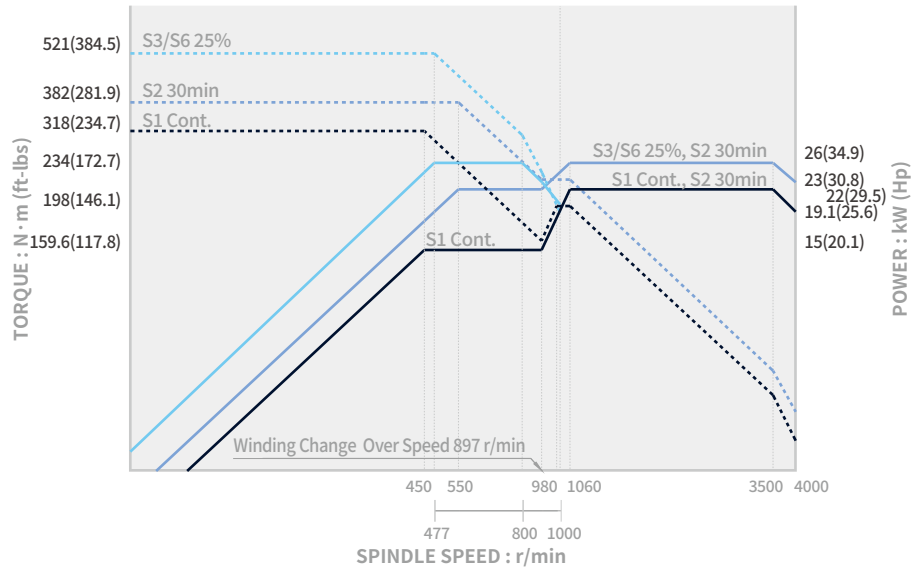

Rotary tool spindle PUMA TT2500MS/SY

Max. spindle speed

5000 r/min

Max. spindle power

5.5/1.5 kW (7.4/2.0 Hp)

Max. Spindle torque

47 N·m (34.7 ft-lbs)

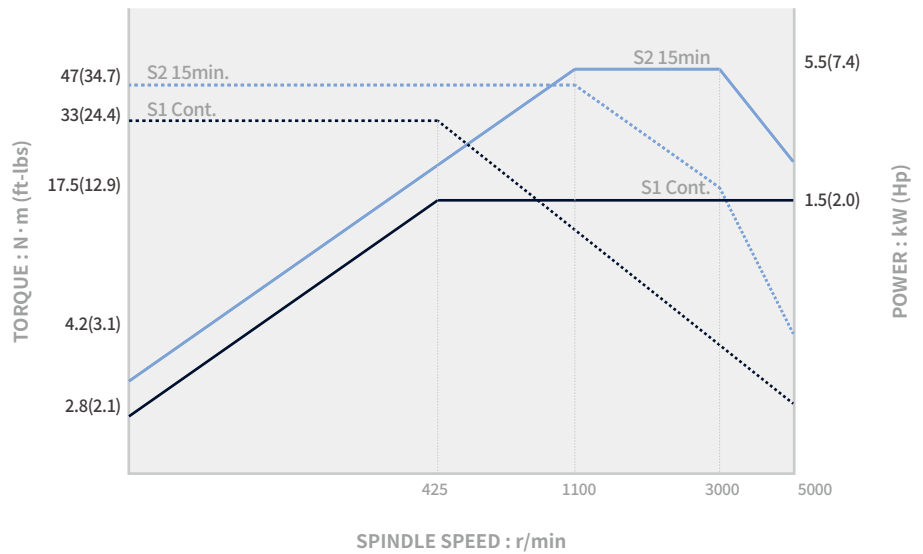

Rotary tool spindle PUMA TT2500MS/SY OPTION

Max. spindle speed

5000 r/min

Max. spindle power

7.5/1.5 kW (7.4/2.0 Hp)

Max. Spindle torque

95.4 N·m (70.4 ft-lbs)

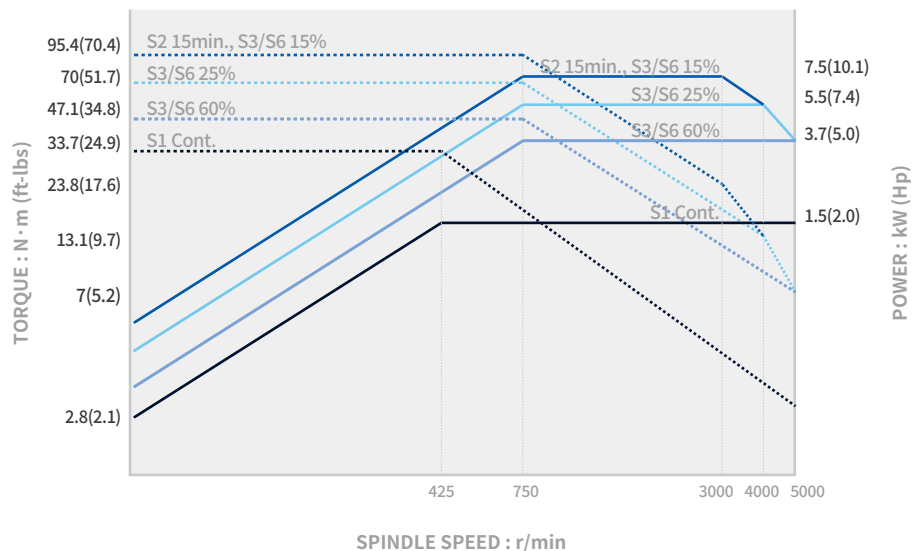

EXTERNAL DIMENSIONS

PUMA TT2500 MS / SY

Unit : mm (inch)

TOP

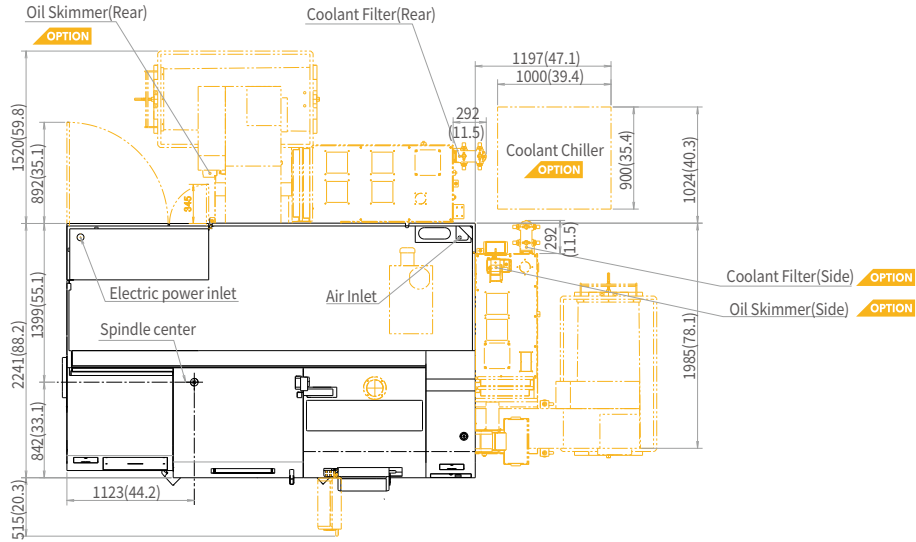

FRONT

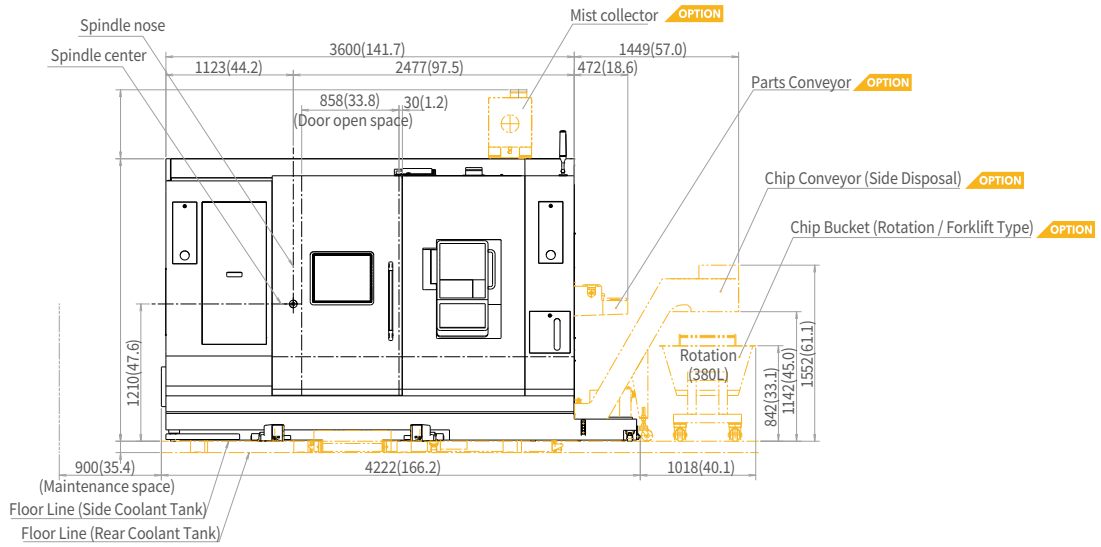

SIDE

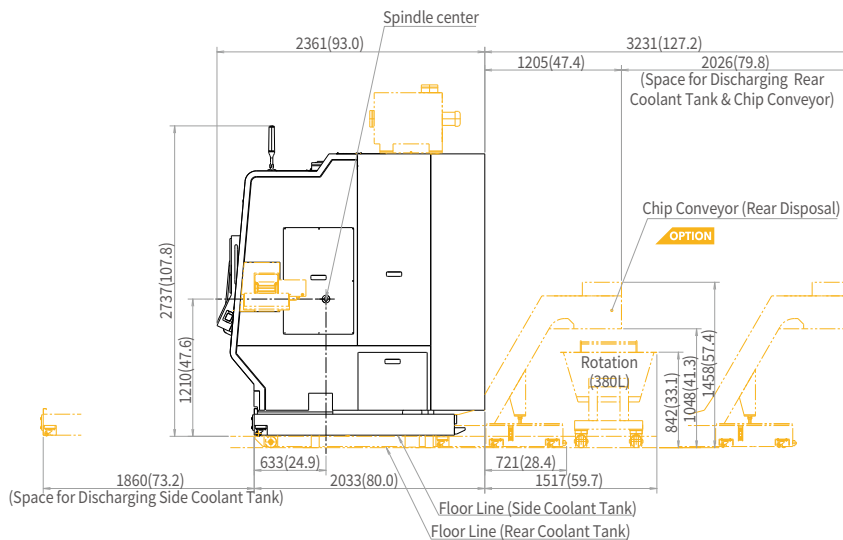

* Some peripheral equipment can be placed in other areas.

TOOLING SYSTEM

PUMA TT2500 MS / SY

Unit : mm (inch)

Standard

* () Supply quantity

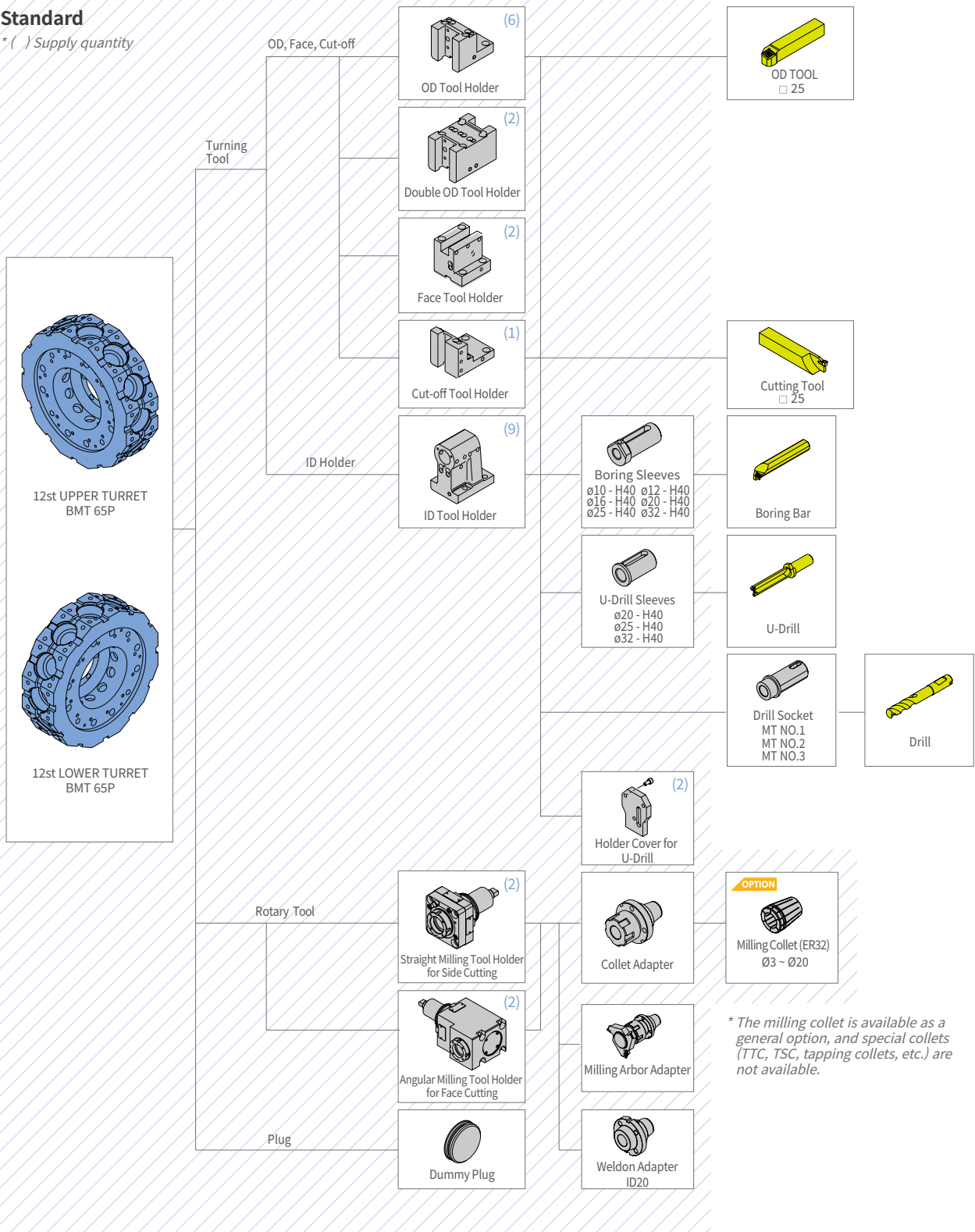

TOOL INTERFERENCE DIAGRAM

PUMA TT2500 MS / SY

Unit : mm (inch)

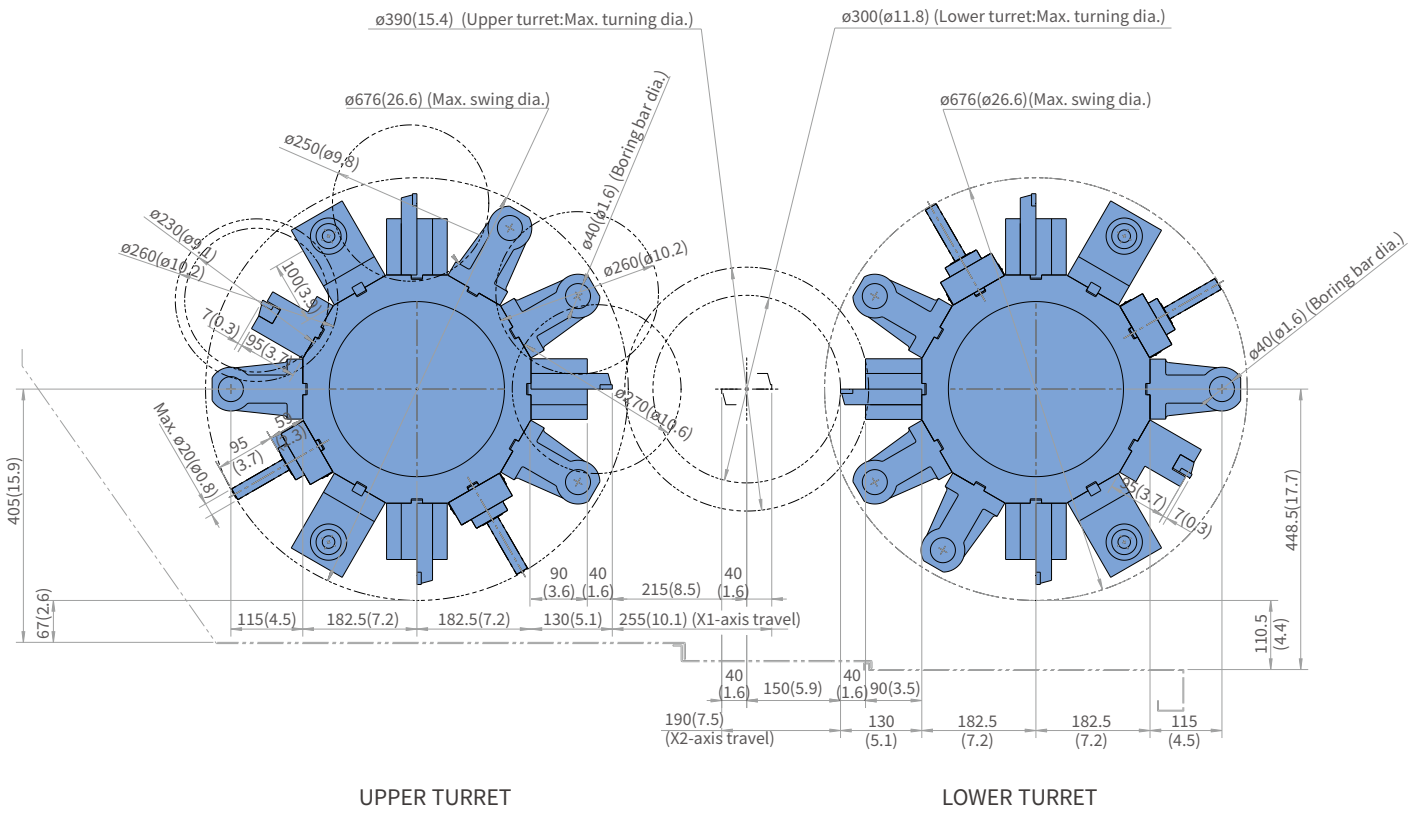

WORKING RANGE DIAGRAM

PUMA TT2500 MS / SY

Unit : mm (inch)

SINGLE OD TOOL HOLDER

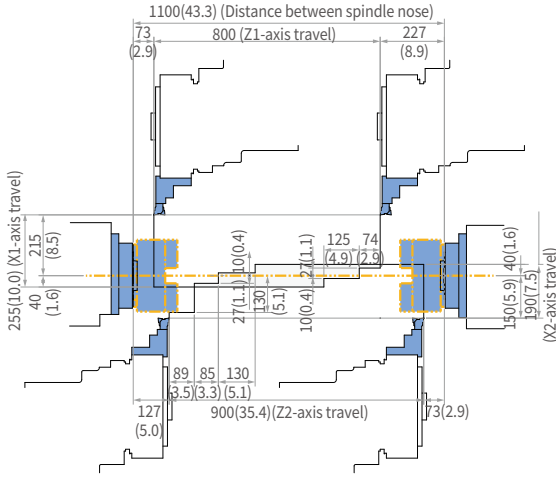

DOUBLE OD TOOL HOLDER

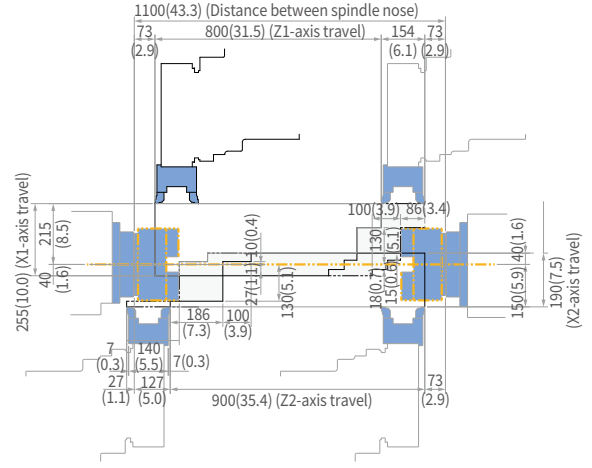

SINGLE ID TOOL HOLDER

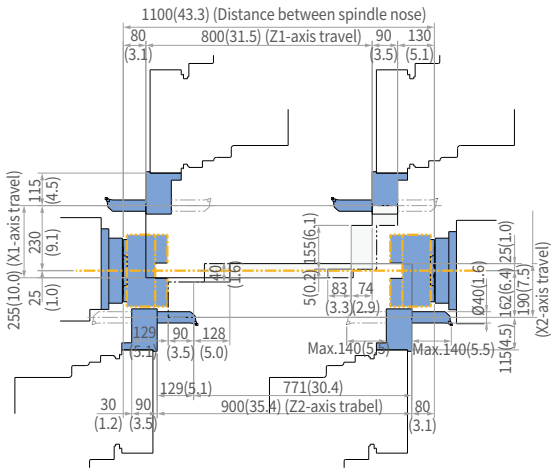

ANGULAR MILLING HEAD

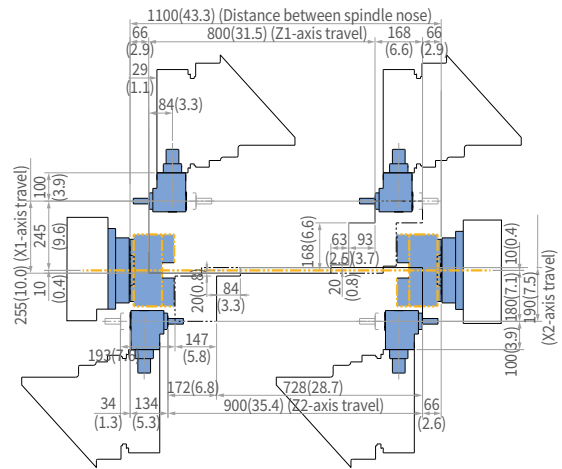

STRAIGHT MILLING HEAD

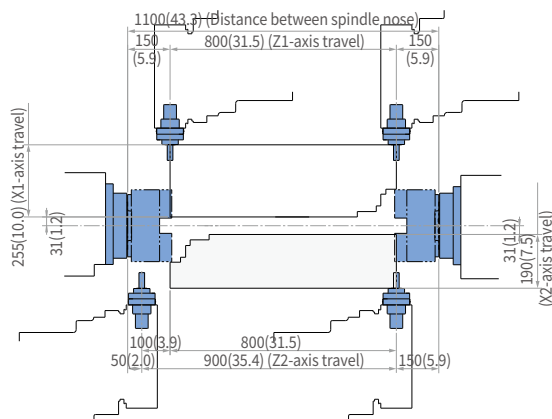

Y AXIS TRAVEL DISTANCE

Angular milling head

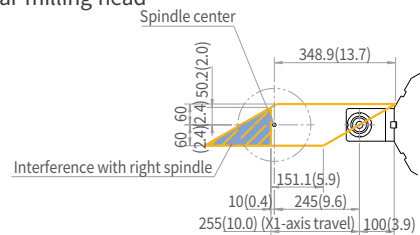

Straight milling head

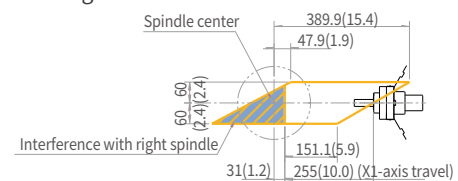

MACHINE SPECIFICATIONS

PUMA TT2500 MS / SY

Description		Unit	PUMA TT2500MS	PUMA TT2500SY	
Capacity	Swing over bed		mm (inch)	800 (31.5)	
	Swing over saddle		mm (inch)	620 (24.4)	
	Max. turning diameter	On upper turret	mm (inch)	390 (15.4)	
		On lower turret	mm (inch)	300 (11.8)	
	Recommended turning diameter		mm (inch)	255 (10.0)	
	Max. turning length		mm (inch)	350 (13.8)	
	Bar working diameter		mm (inch)	81 (3.2)	
Spindle (Left/Right)	Spindle speed		r/min	4000	
	Spindle nose		ASA	A2-8	
	Spindle bearing diameter (front)		mm (inch)	130 (5.1)	
	Spindle through hole diameter		mm (inch)	Left/Right: 91 (3.6)	
	C1-axis minimum indexing increment		deg	0.001	
Travels	X1-axis		mm (inch)	255 (10.0)	
	Z1-axis		mm (inch)	800 (31.5)	
	A-axis		mm (inch)	810 (31.9)	
	X2-axis		mm (inch)	190 (7.5)	
	Z2-axis		mm (inch)	900 (35.4)	
	C1, C2-axis		deg	360	
	Y-axis		mm (inch)	-	120 (±60) (4.7 (±2.4))
Rapid traverse rate	X1, 2-axis		m/min (ipm)	20 (787.4)	
	Z1, 2-axis		m/min (ipm)	24 (944.9)	
	A-axis		m/min (ipm)	24 (944.9)	
	C1, C2-axis		r/min	200	
	Y-axis		m/min (ipm)	-	75 (2952.8)
Turret (Upper/Lower)	Number of tool stations		ea	12	
	OD tool size		mm (inch)	25 x 25 (1.0 x 1.0)	
	Max. boring bar size		mm (inch)	Ø40 (Ø1.6)	
	Turret indexing time	1 station swivel	sec	0.2	
	Max. rotary tool speed		r/min	5000	
Motor	Spindle motor power (Left/Right)		kW (Hp)	26 / 22 (34.9 / 29.5) (30min/Cont.)	
	Servo motor power	X1-axis	kW (Hp)	4 (5.4)	
		X2-axis	kW (Hp)	3 (4.0)	
		Z1, 2-axis	kW (Hp)	4 (5.4)	
		A-axis	kW (Hp)	4 (5.4)	
		Y-axis	kW (Hp)	-	3 (4.0)
Coolant pump motor power		kW (Hp)	0.4 (0.5)		
Power source	Required power capacity		kVA	86.81	86.83
Machine dimensions	Machine size	Floor space	mm (inch)		4220 x 2360 (166 x 87)
		Height	mm (inch)	2340 (92)	2490 (98)
	Machine weight (Net)		kg (lb)	12700 (27998.3)	
Control	CNC system		DN Solutions Fanuc i Plus {Fanuc 31i} *		



Head Office

19F, 10, Tongil-ro, Jung-gu Seoul,
Republic of Korea, 04527
Tel: +82-2-6972-0370/0350
Fax: +82-2-6972-0400

DN Solutions America

360 E State PKWY,
Schaumburg, IL. 60173,
United states
Tel: +1-973-618-2500
Fax: +1-973-618-2501

DN Solutions Europe

Emdener Strasse 24, D-41540
Dormagen, Germany
Tel: +49-2133-5067-100
Fax: +49-2133-5067-111

DN Solutions India

No.82, Jakkuar Village
Yelahanka Hobil,
Bangalore-560064
Tel: + 91-80-2205-6900
E-mail: india@dncompany.com

DN Solutions China

Room 101,201,301, Building 39 Xinzhuan Highway
No.258 Songjiang District China Shanghai (201612)
Tel: +86 21-5445-1155
Fax: +86 21-6405-1472

DN Solutions Vietnam

M.O.R.E building 2F, 40A-40B Ut Tich Street, 04 Ward 04,
District Tan Binh District, Ho Chi Minh City, Vietnam
Tel: +84 28-7304-0163

Sales inquiry

sales@dncompany.com