

Robot Easy 250

Simply efficient



Is your production asleep?

Your machines are profitable when they are producing. They should run during the day, in off-peak hours and at night, even on weekends. Achieving this goal means combining all production requirements in a plan.

The plan is called "Flexible Manufacturing Concept – FMC". It is implemented in carefully measured steps.

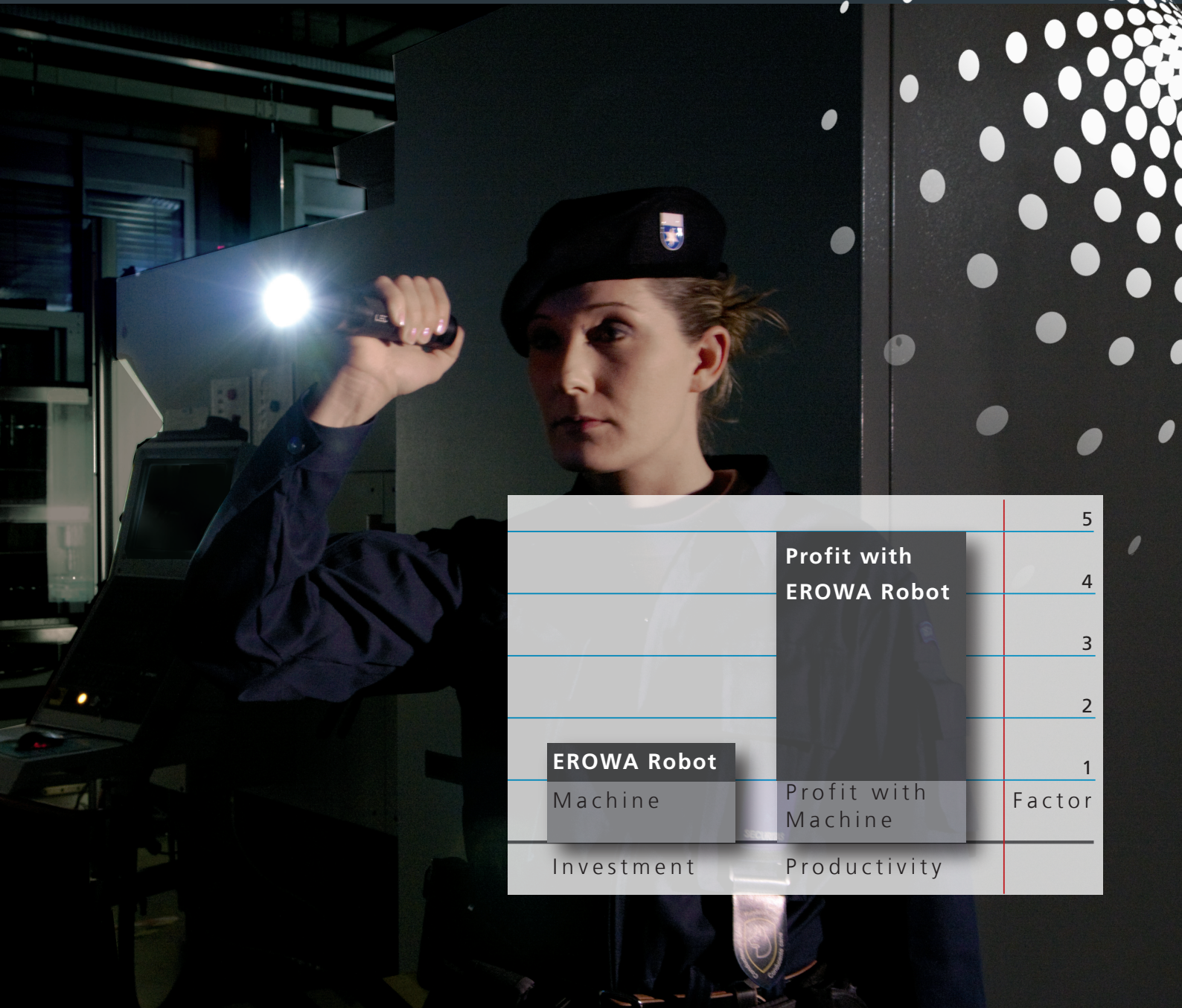

| | | |
|-------------|-------------------------|--------|
| | | 5 |
| | Profit with EROWA Robot | 4 |
| | | 3 |
| | | 2 |
| EROWA Robot | | 1 |
| Machine | Profit with Machine | Factor |
| Investment | Productivity | |

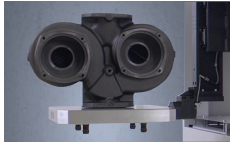

Easy up to 250 kg **4**
Transfer weight of up to 250 kg

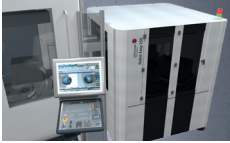

Easy to install **6**
Variants for different workpiece sizes

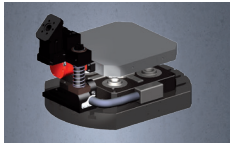

Easy to retrofit **8**
Fits all machines

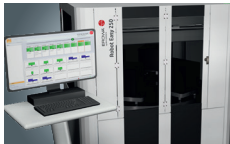

Easy to control **10**
Advanced process control system



Easy to recoup **12**
Recouped in a year



25 years of experience **14**
Quickly installed and ready

Easy up to 250 kg

The Robot Easy is robust and sturdy. For large and heavy workpieces there is hardly a more economical solution. The long extension path leaves no wish unfulfilled.

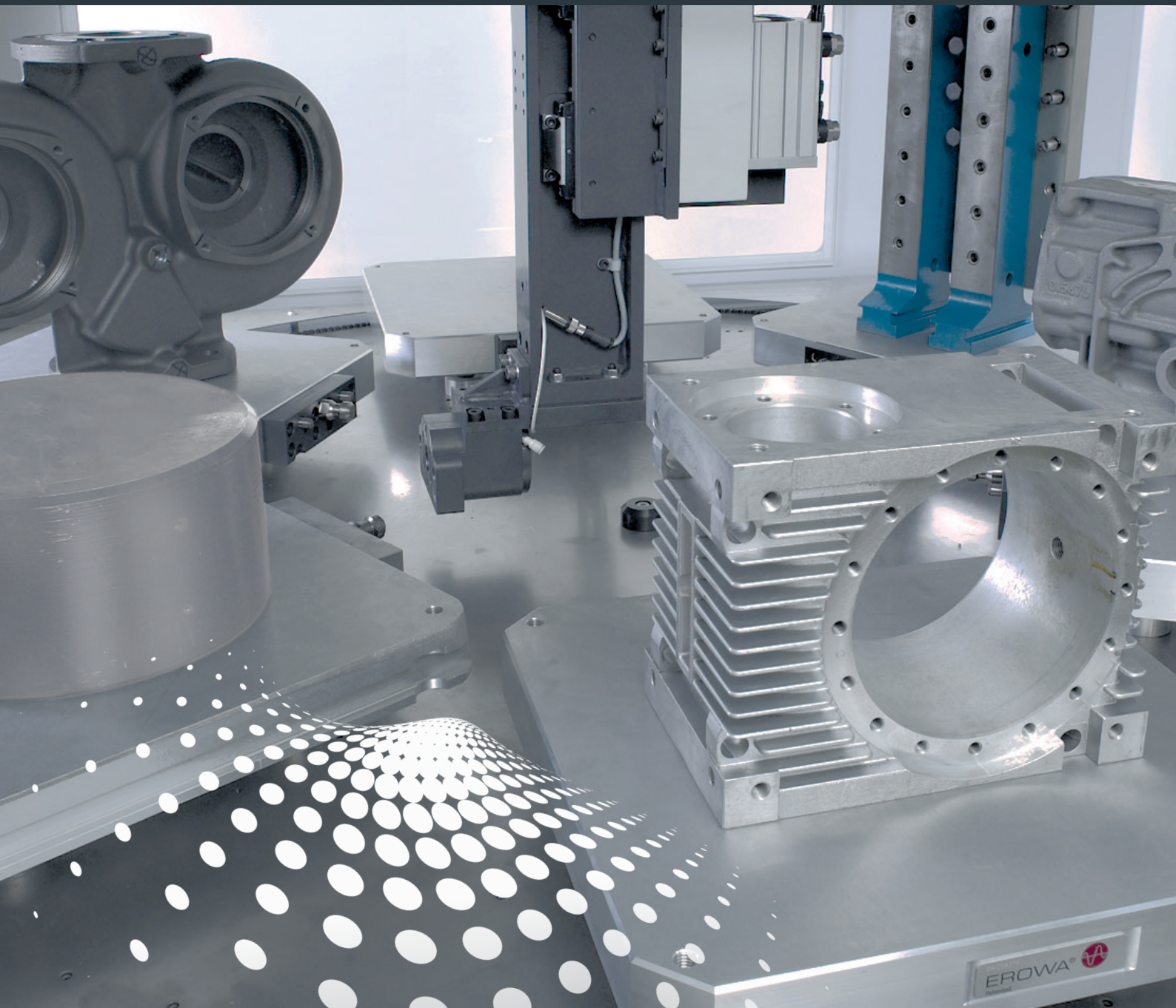



Moving 250 kg is no problem for the Robot Easy. Its robust design takes care of reliable pallet changes.

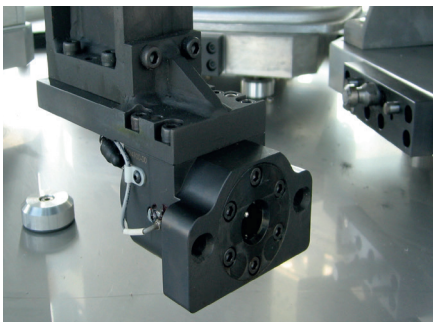

Strong is the RCS5 gripper. The internal monitoring system contributes to process reliability.

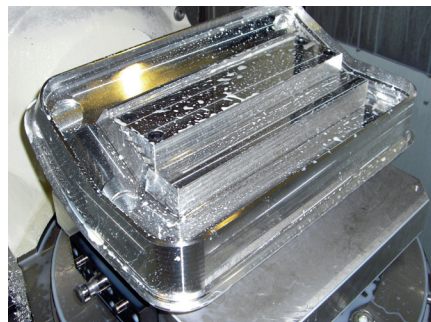

Large workpieces measuring L 500 x W 500 x H 400 mm fit in the magazine.

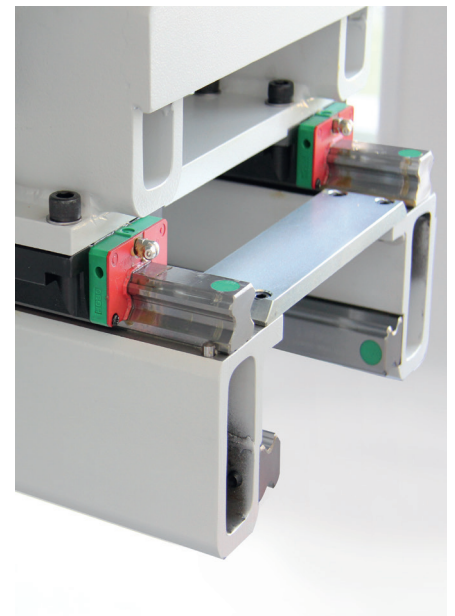

The axis remains stable even extended to 2500 mm. This is ensured by the design with double linear guides.

HEAVY WORKER

Workpiece size 500 x 500 x 400 mm
Transfer weight 250 kg

Easy to install

The Robot Easy fits all machines.
There are two different transfer axes to choose from,
depending on the workpiece weight.

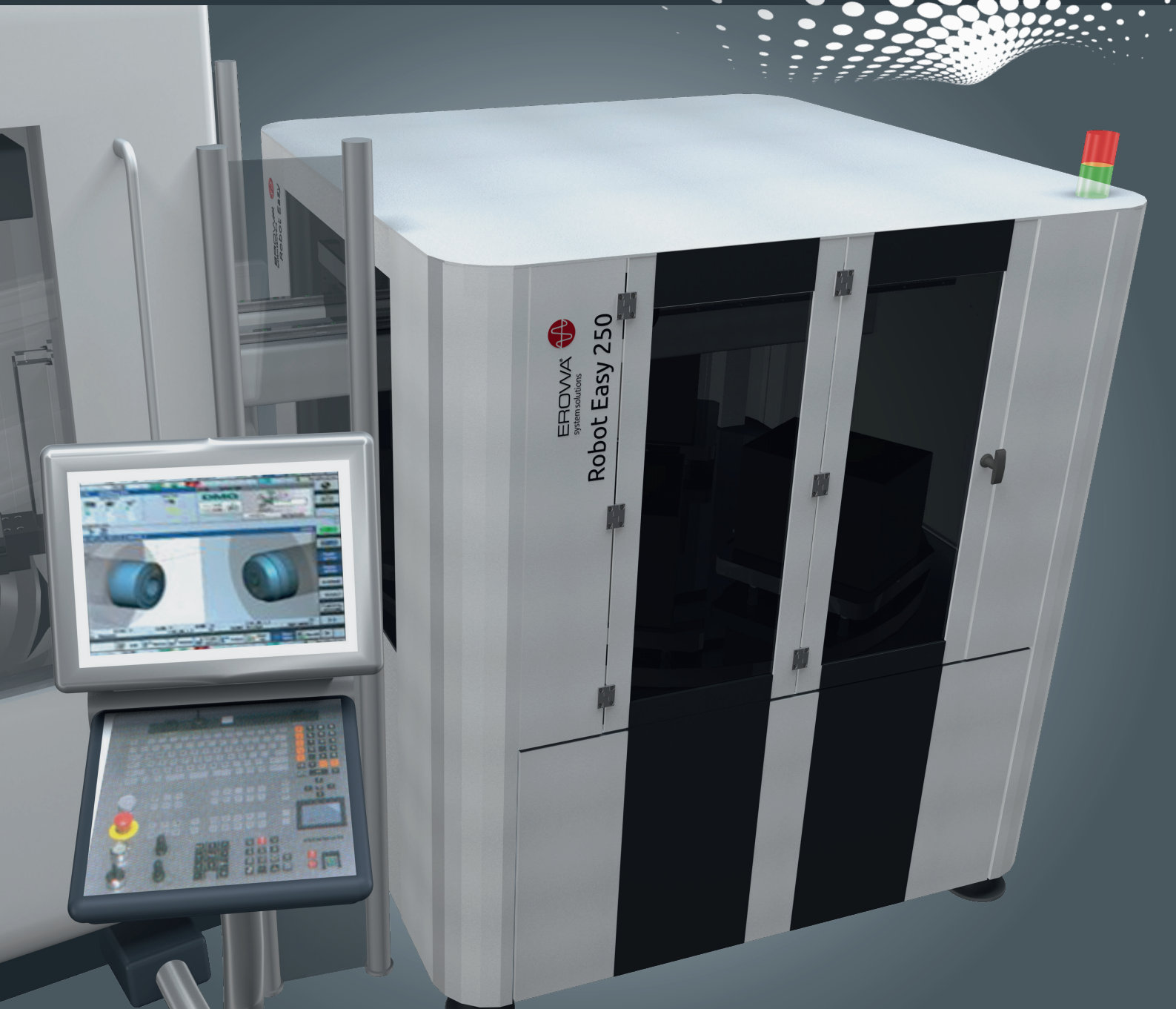

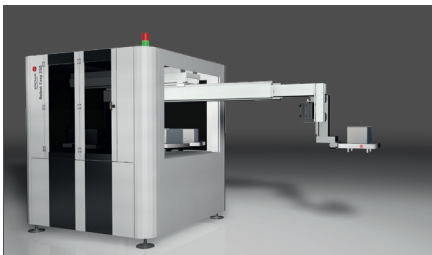
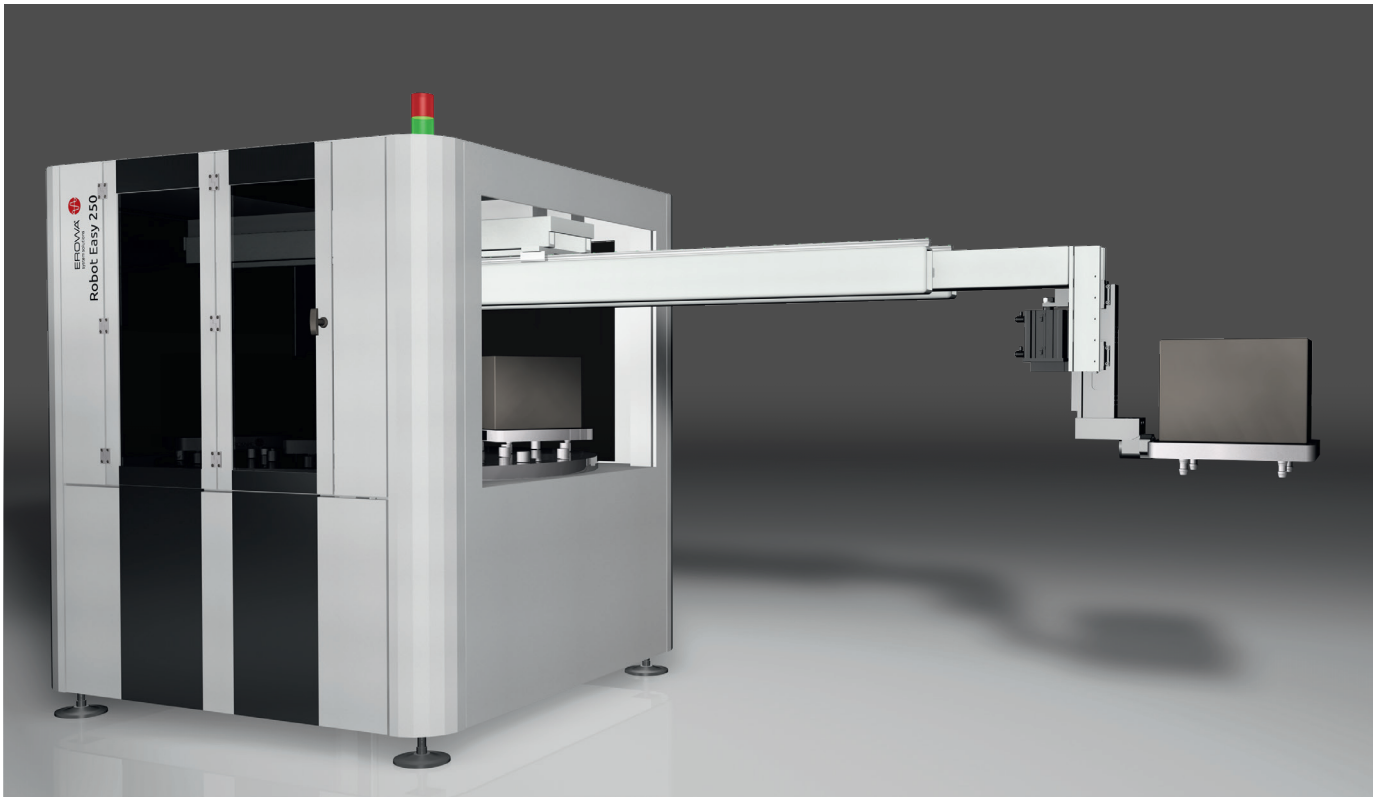

The long travel between the machine and the robot leaves enough space for manual work.

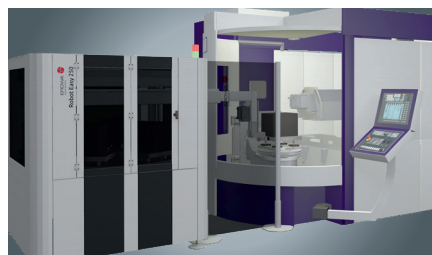

Machines with automatic workpiece change can deliver up to 4000 productive hours per year.

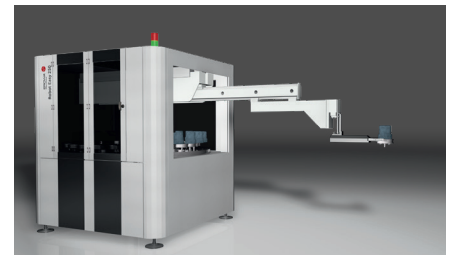

The "light" transfer axis is ideally suited to move pallets of up to 40 kg into the machine.

SUITABLE

For milling, drilling and grinding
Integrated height adjustment
Choice of transfer axis
Choice of magazine configuration

Easy to retrofit

The Robot Easy can be integrated with existing machines. More productivity is a direct result.

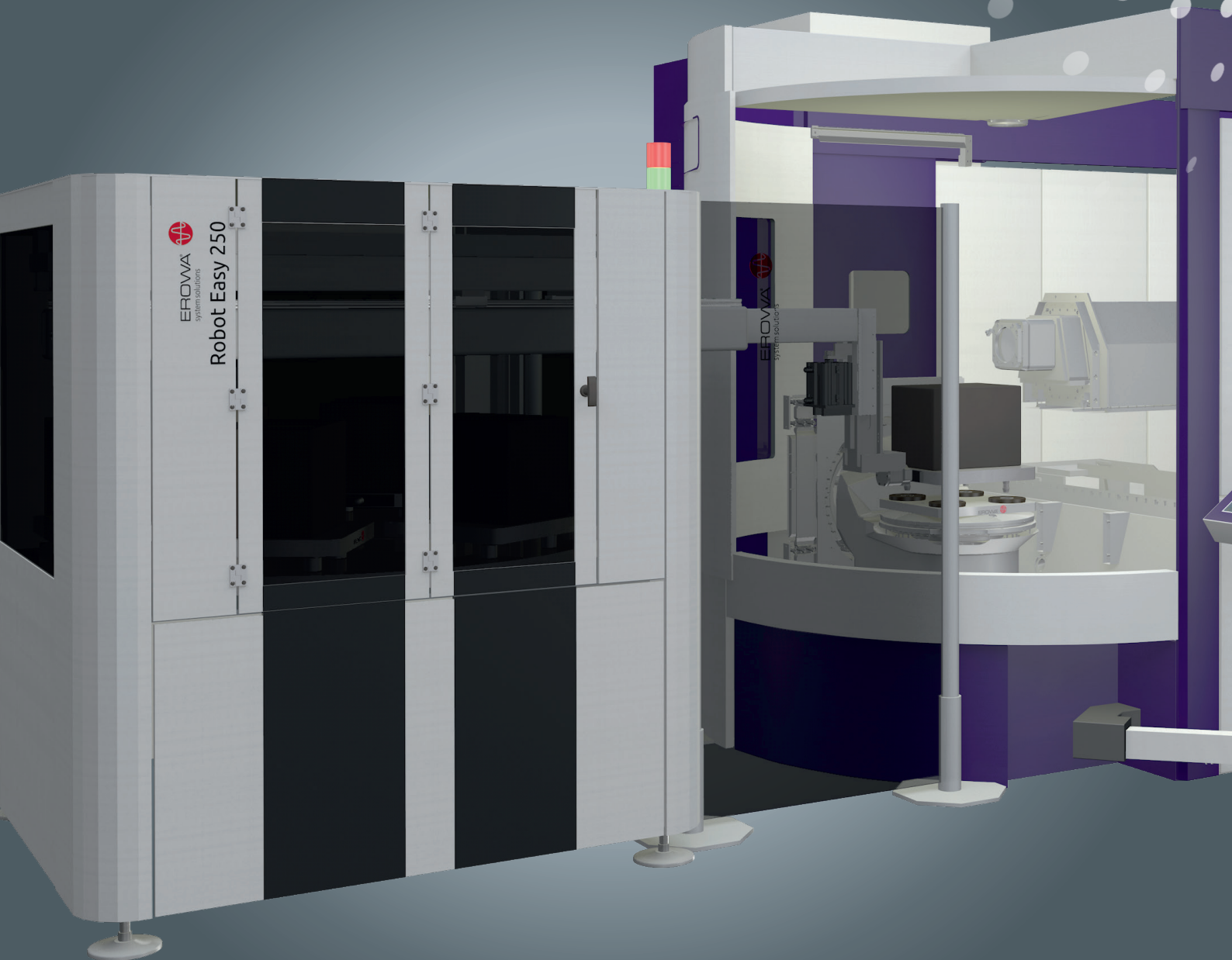

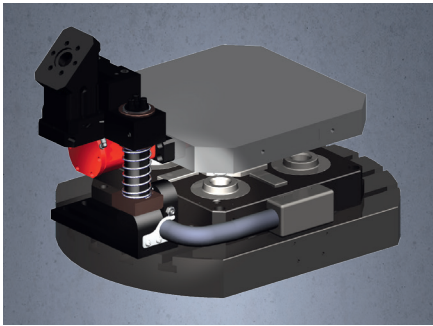

AirDock

Retrofitting air lines is often uneconomical on rotary tables. The Robot Easy solves this task with the AirDock option.

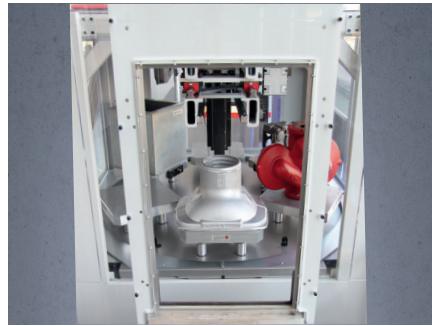

RoboDoor

For machines without an automatic door: RoboDoor. Well thought-out, quickly retrofitted, customized dimensions.

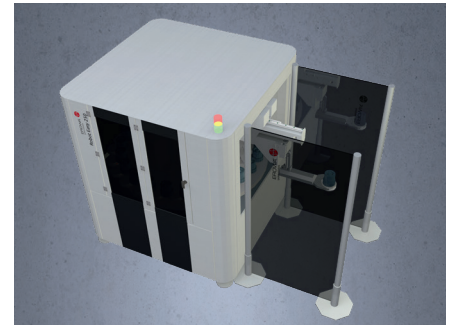

Safety barriers

Safety rates high as well. Barriers and access doors are added on request.

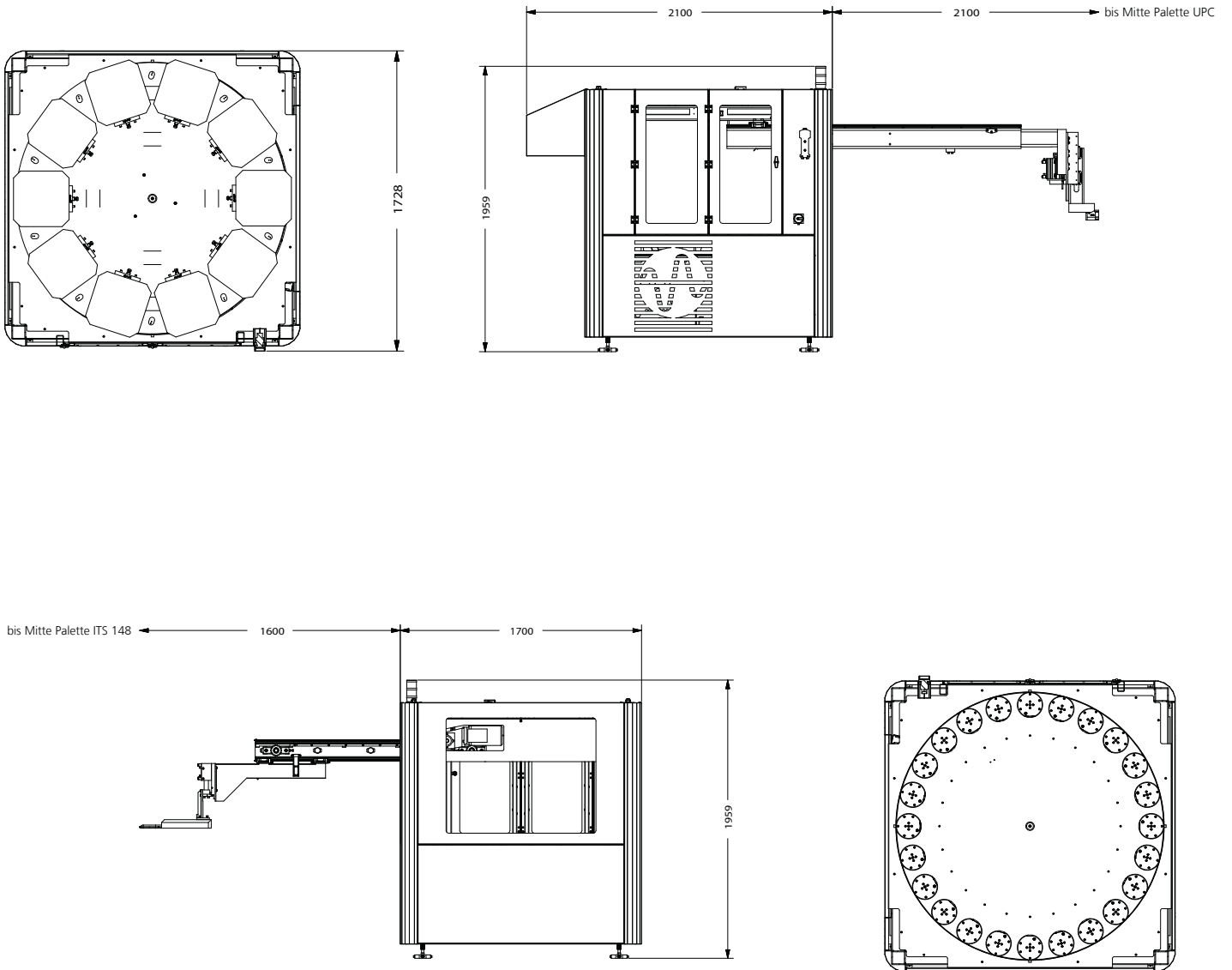

Easy to control

A real pleasure to work opens up when the machine and robot are controlled via the EMC³ process control system.

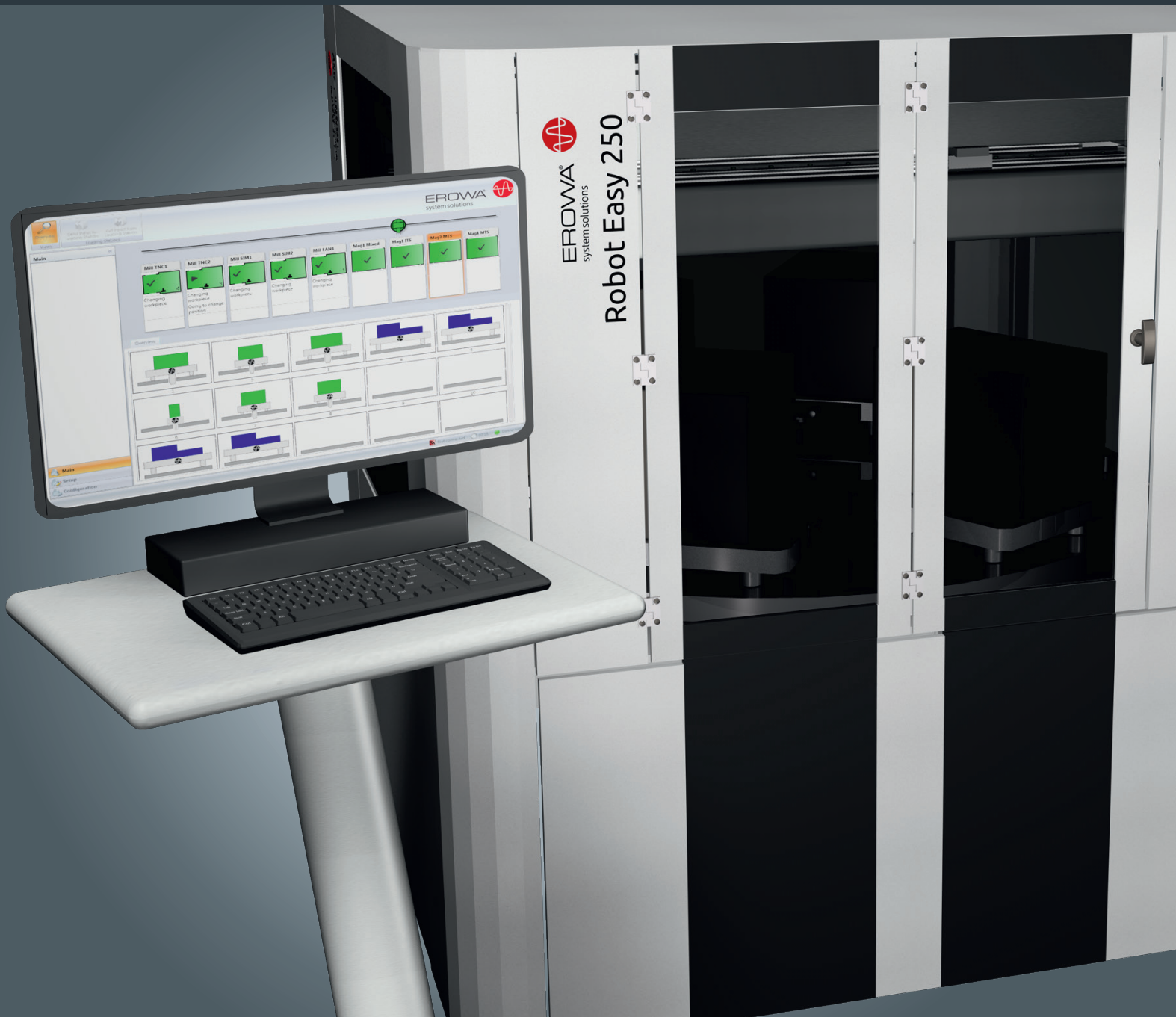

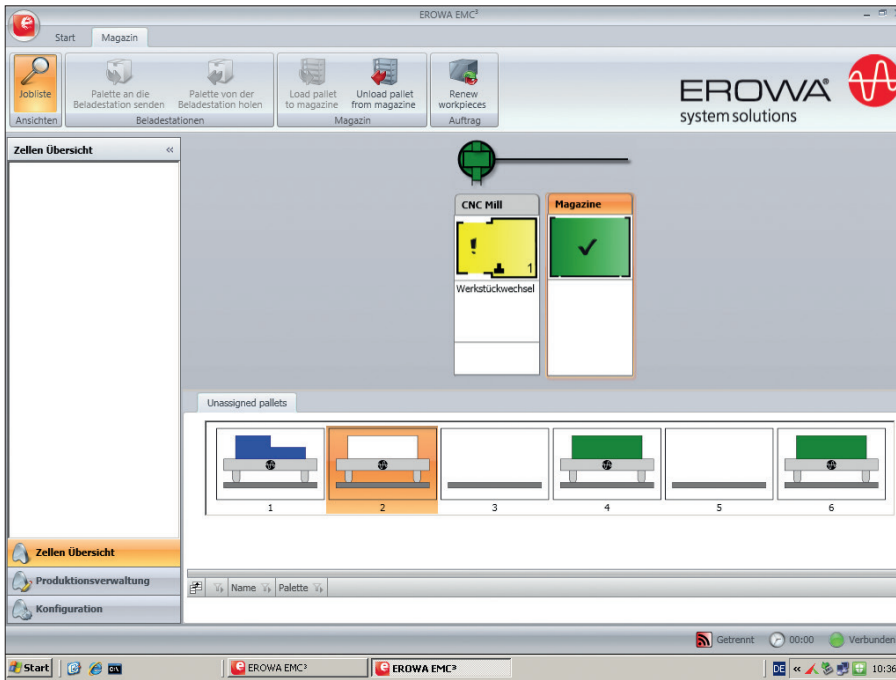

The operator is always being kept in the loop. CNC programs, set workpieces, currently remaining machining time, tool states and other information are available online.



See at a glance: the current autonomy of the system.

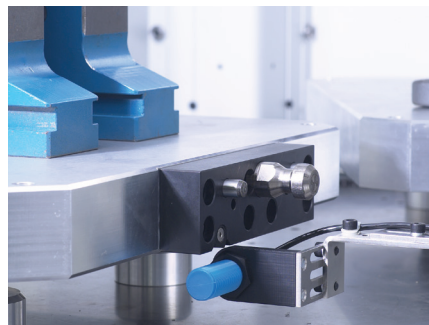

With the EWIST™ system, you always know each pallet's location, and the correct pallet is found automatically.

| Name | State | Locked | Initial Lifetime | Remaining Lifetime | Remaining Lifetime in % | Family |
|---------------|---------------|--------|------------------|--------------------|-------------------------|----------|
| 50 77308800.3 | Not Monitored | | 00:00:00 | 00:00:00 | | 77308800 |
| 52 37000900.1 | Ready | | 02:00:00 | 01:57:00 | | 37000900 |
| 53 46106301.1 | Error | 🔒 | 00:55:00 | 00:55:00 | | 46106301 |
| 54 35100900.1 | Ready | | 01:40:00 | 00:40:00 | | 35100900 |
| 55 49109000.3 | Error | 🔒 | 00:30:00 | 00:30:00 | | 49109000 |
| 56 70010000.1 | Error | 🔒 | 01:20:00 | 00:42:00 | | 70010000 |
| 57 38000800.3 | Ready | | 01:40:00 | 01:40:00 | | 38000800 |
| 59 53003301.1 | Ready | | 00:50:00 | 00:32:00 | | 53003301 |
| 60 70008701.1 | Ready | | 01:20:00 | 00:58:00 | | 70008701 |
| 61 53009001.1 | Ready | | 00:50:00 | 00:35:00 | | 53009001 |
| 62 21006001.1 | Not Monitored | | 00:00:00 | 00:00:00 | | 21006001 |
| 63 53009501.1 | Ready | | 01:20:00 | 00:55:00 | | 53009501 |
| 64 52108125.1 | Not Monitored | | 00:00:00 | 00:00:00 | | 52108125 |
| 65 53010201.1 | Ready | | 01:20:00 | 01:01:00 | | 53010201 |

With different filter functions, the situation in the machine's tool memory is clearly displayed.

KEEPS YOU IN THE LOOP

- Color code for quick overview
- Intuitive layout for the operators
- Logical process steps
- Current information

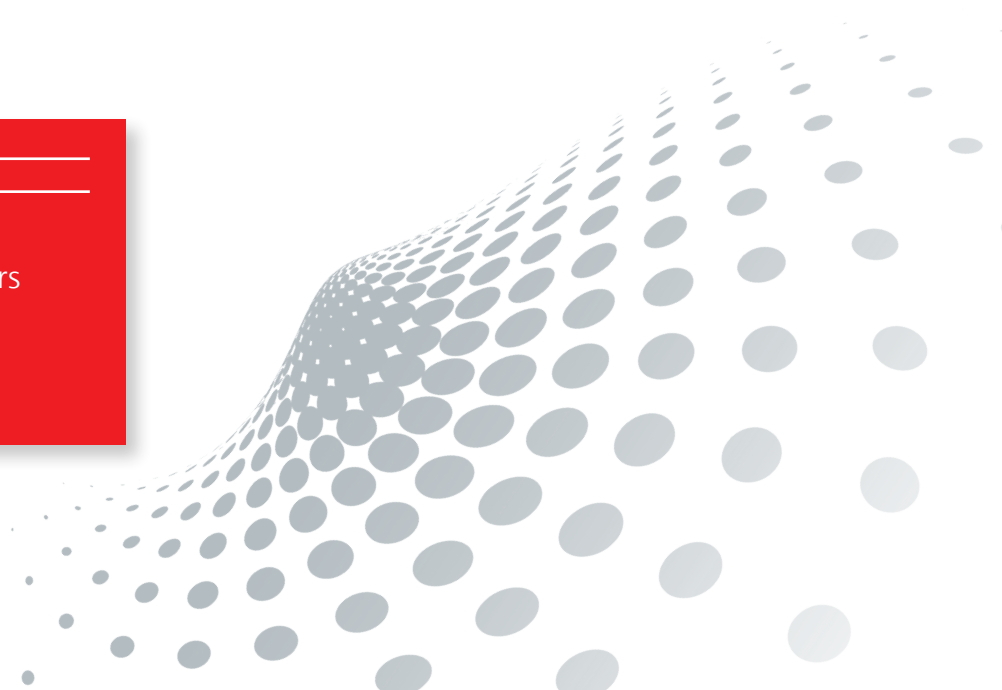

Easy to recoup

The investment will pay for itself within a year. The large increase in autonomy allows 4000 and more productive hours.



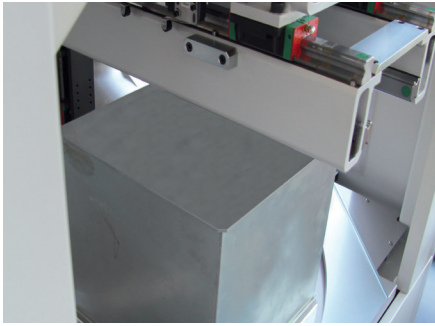

Rugged design for use around the clock.

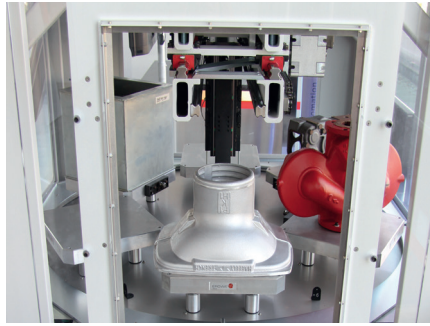

Worklist for many off-peak and night hours.



Integrated intelligence – once set up, the processes run almost automatically.



Top loading door for crane operation.

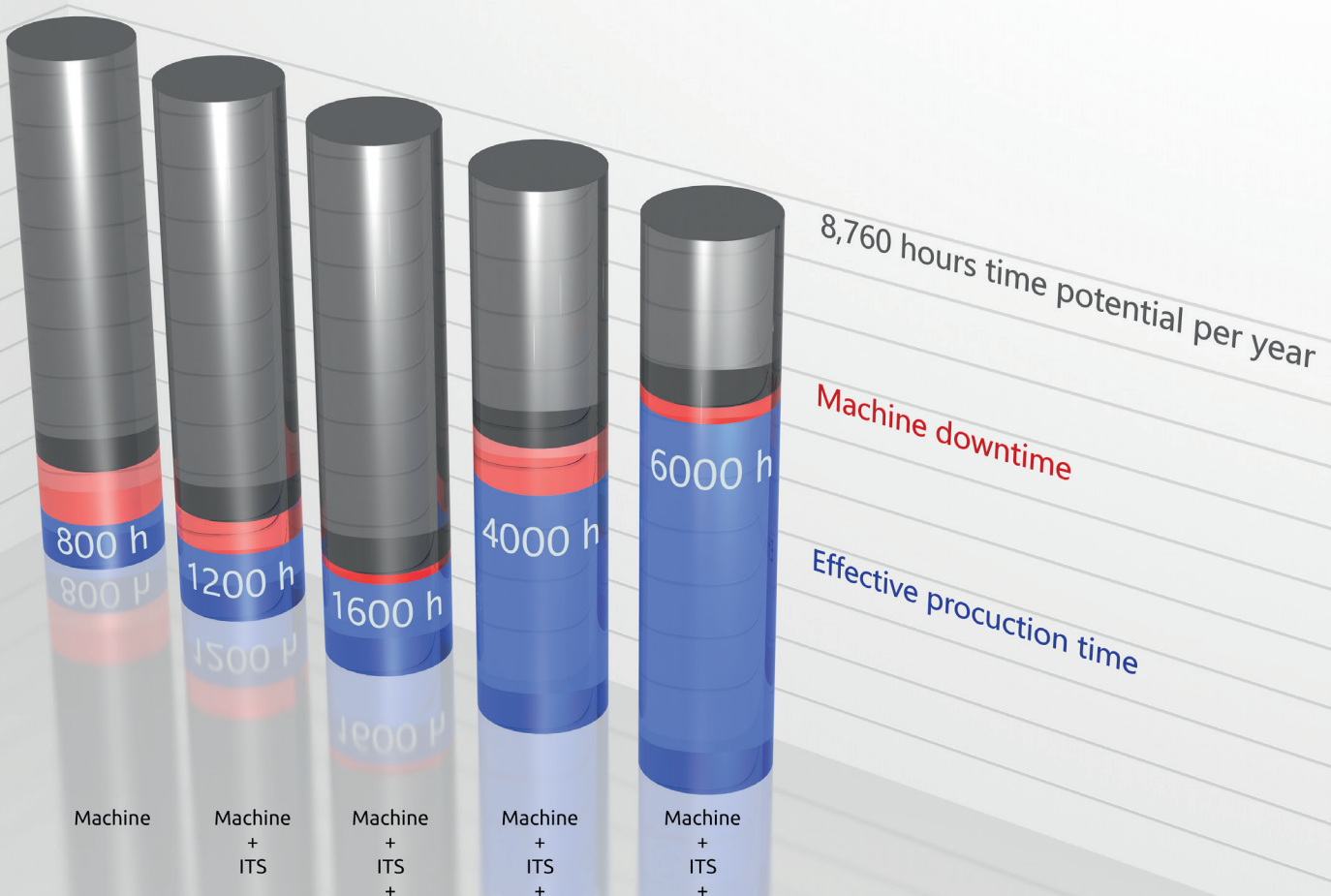

30 years of experience

Long experience - short start-up.

EROWA robots consist of sophisticated, standardized components. This allows short set-up times.

Your critical benefits

- Everything from one single source
- Independent partner
- Perfect service with worldwide application
- Experience with over 4000 robots
- Standardized interfaces
- Long-life systems
- Integrated security system

The Facts

- 250 kg transfer weight
- Magazine with 4 to 60 positions
- Monoblock architecture

Extension options

- AirDock for air supply to the machine table
- EWIS™ automatic pallet recognition
- Control system EMC³
- Safety barriers

THE NUMBER OF PALLET POSITIONS DEPENDS ON THE TOOLING USED.

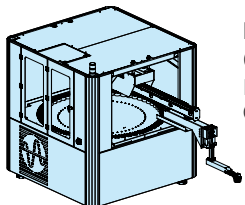

ITS 50/72
60 x ITS 50
Holder 72
(Light axis)



Workpiece height = 170 mm

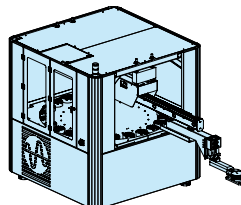

ITS 115/148
24 x ITS 115/148
(Light axis)



Workpiece height = 190 mm

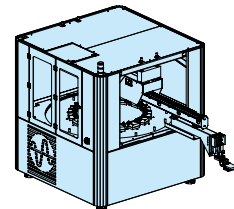

PalletSet W
7 x frame
15 x holder
(Light axis)

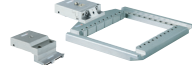

Workpiece height = 170 mm

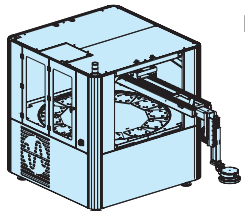

PC 210
12 x PC 210

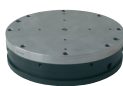

Workpiece height = 440 mm

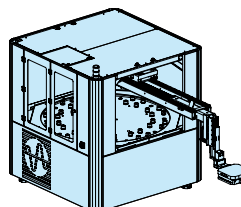

UPC
10 x UPC

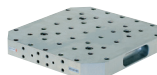

Workpiece height = 400 mm

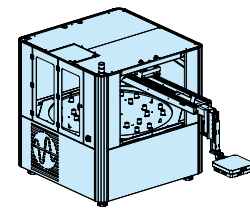

MTS 400
ITS MTS 400
6 x ITS MTS 400



Workpiece height = 400 mm

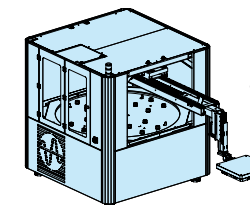

MTS 500
ITS MTS 500
4 x ITS MTS 500



Workpiece height = 400 mm

SYSTEM GRIPPERS



RCS 5 gripper for MTS/UPC/PalletSet W
Capacity MTS max. 250 kg
Capacity UPC max. 130 kg
Capacity PalletSet W 30 kg



PC210 gripper for PC210
Pallets with ring groove
Capacity max. 130 kg



ITS 148 gripper for ITS 148 pallets
Capacity max. 40 kg



ITS 115 gripper for ITS 115 pallets
Capacity max. 40 kg



PM 56 gripper for PM Tooling.
Capacity max. horizontal/vertical 5 kg



PM 85 and PM 130 gripper for PM tooling. Capacity max horizontal 20 kg, vertical 10 kg



Gripper for ITS holder 72
Capacity max. 20 kg



S gripper for ITS 50 holder
Capacity max. 20 kg



Combo gripper for ITS and Compact tooling. Capacity max. horizontal 8 kg

TECHNICAL DETAILS

TRANSFER WEIGHT

Standard max. **250 kg**
Light axis max. **40 kg**

TRANSFER AXIS

Transfer path (option) mm **1600 (2500)**
System size L x W x H mm **1700x1700 (2100)x1800**

MAGAZINE POSITIONS

Magazine capacity **4-60 positions depending on pallet size**

ELECTRONICS

Automatic pallet recognition **Yes / EWIS™**
Process control system interface **Yes**

The next step

Important things need to be planned. And your next step is certainly among the important things. For it is your start into a new, efficient era. We are pleased to be with you on the way. As consultants, in practice. For you to know at all times what you're engaging in. The next EROWA branch office is not far – **take the step.**



USA

EROWA Technology, Inc.
North American Headquarters
2535 South Clearbrook Drive
Arlington Heights, IL 60005
USA
Tel. 847 290 0295
Fax 847 290 0298
e-mail: info@erowa.com
www.erowa.com

Italy

EROWA Tecnologie S.r.l.
Sede Legale e Amministrativa:
Via Alfieri Maserati 48
IT-10095 Grugliasco (TO)
Italy
Tel. 011 9664873
Fax 011 9664875
info@erowa.it
www.erowa.com

Unità di Treviso:
Via Leonardo Da Vinci 8
IT-31020 Villorba (TV)
Italy
Tel. 0422 1627132

Singapore

EROWA South East Asia Pte. Ltd.
56 Kallang Pudding Road
#06-02, HH@Kallang
Singapore 349328
Singapore
Tel. 65 6547 4339
Fax 65 6547 4249
sales.singapore@erowa.com
www.erowa.com

Japan

EROWA Nippon Ltd.
Sibadaimon Sasano Bldg.
2-6-4, Sibadaimon, Minato-ku
105-0012 Tokyo
Japan
Tel. 03 3437 0331
Fax 03 3437 0353
info@erowa.co.jp
www.erowa.com

Switzerland

EROWA AG
Knutwilerstrasse 3
CH-6233 Bülloz
Switzerland
Tel. 041 935 11 11
Fax 041 935 12 13
info@erowa.com
www.erowa.com

France

EROWA Distribution France Sàrl
PAE Les Glaisins
12, rue du Bulloz
FR-74940 Anney-le-Vieux
France
Tel. 4 50 64 03 96
Fax 4 50 64 03 49
erowa.france@erowa.com
www.erowa.com

Spain

EROWA Technology Ibérica S.L.
c/Via Trajana 50-56, Nave 18
E-08020 Barcelona
Spain
Tel. 093 265 51 77
Fax 093 244 03 14
erowa.iberica.info@erowa.com
www.erowa.com

China

EROWA Technology (Shanghai) Co., Ltd.
G/F, No. 24 Factory Building House
69 Gui Qing Road (Caohejing Hi-tech Park)
Shanghai 200233, PRC
China
Tel. 021 6485 5028
Fax 021 6485 0119
info@erowa.cn
www.erowa.com

Germany

EROWA System Technologien GmbH
Gewerbegebiet Schwadernmühle
Roßendorfer Straße 1
DE-90556 Cadolzburg/Nbg
Germany
Tel. 09103 7900-0
Fax 09103 7900-10
info@erowa.de
www.erowa.de

Scandinavia

EROWA Technology Scandinavia A/S
Fasanvej 2
DK-5863 Ferritslev Fyn
Denmark
Tel. 65 98 26 00
Fax 65 98 26 06
info.scandinavia@erowa.com
www.erowa.com

Eastern Europe

EROWA Technology Sp. z o.o.
Eastern Europe
ul. Spółdzielcza 37-39
55-080 Kały Wrocławskie
Poland
Tel. 71 363 5650
Fax 71 363 4970
info@erowa.com.pl
www.erowa.com

India

EROWA Technology (India) Private Limited
No: 6-3-1191/6, Brij Tarang Building
Unit No-3F, 3rd Floor, Greenlands, Begumpet,
Hyderabad 500016 (Telangana)
India
Tel. 040 4013 3639
Fax 040 4013 3630
sales.india@erowa.com
www.erowa.com