



Indexable Drills

Tool Selection Guide	J2–J3
Drill Fix DFR, DFSP, and DFT	J4–J50
Drill Fix DFR.....	J4, J8–J18
Drill Fix DFSP.....	J4, J20–J40
Drill Fix DFT.....	J5, J42–J46, J48–J50
HTS Series Indexable Deep-Hole Drilling System	J52–J83
HTS and HTS-R Indexable Drill System	J52–J83
Indexable Drill Inserts	J84–J94
Drill Fix DFR Inserts	J84–J86
Drill Fix DFT Inserts.....	J85–J88
Drill Fix DFSP Inserts	J89–J90
CTR Counterboring Tools	J96–J101
Counterboring Inserts	J99–J101



		standard						hole tolerance	standard range		customised solution range	
									diameter range		diameter range	
		● first choice ○ alternate choice							D1 mm min-max	drilling depth L/D1	D1 mm min-max	drilling depth
		P	M	K	N	S	H					
	DFR™ Indexable Drill Body Short-Hole Drilling	●	●	●	●	●	IT9-11	12,5-25	2 x D 3 x D 4 x D	12,5-26	1-5 x D	
	DFSP™ Indexable Drill Body Short-Hole Drilling	●	●	●	●	●	IT9-11	14-55	2 x D 3 x D 4 x D 5 x D	14-85	1-5 x D	
	DFT™ Indexable Drill Body Short-Hole Drilling	●	●	●	●	●	IT9-11	16-83	2.5 x D 4 x D	15,8-83	1-5 x D	
	HTS-R Indexable Drilling Tool Deep-Hole Drilling	●	●	●	●	●	IT9-11	40-55	10 x D	40-55	1-10 x D	
	HTS Indexable Drilling Tool Deep-Hole Drilling	●	●	●	●	●	IT9-11	45-270	10 x D	45-540	1-10 x D	
	S2 S Countersinking Countersinking Tool	●	●	●	●	●	IT9-11	15,1-46,2	1 x D	11,5-150	1-5 x D	

In regard to insert and drill coatings, anything is possible. If a specific insert or drill is not suitable for your workpiece material, please contact our Engineered Solutions Department for an offer about special coatings and edge preparations.

*Except for L/D 5 x D.

¹⁾ Other shank styles available as customised solution.

	■ standard capabilities ¹⁾								■ standard and □ customised solution capabilities								page(s)
	coolant																
		■															■ ■
		■		■ ■	■	■			■	■	■	■	■	□	□	□	J22–J40
		■		■ ■	■	■			■	■	■	■	■	□	□		J44–J50
		■			■		■	■	■								J67–J70
		■			■		■	■	■								J72–J83
		■	■											■	□		J98–J101

➤ Drill Fix™ DFR™, DFSP™, and DFT™

Primary Application

Drill short holes up to 5 x D with DFR, DFSP, and DFT indexable drills in steel, cast iron, ductile iron, stainless steel, and non-ferrous materials. The Drill Fix portfolio covers the diameter range 12,5–85mm (.500–3.250").

Features and Benefits

Drill Fix DFR

- Diameter range of 12,5–24mm (.500–1.000") in 2 x D, 3 x D, and 4 x D.
- Rectangular-shaped inserts offer the highest stability and feed rates at smaller sizes.
- Long tool life due to soft starting cut, short chips, and low cutting forces.
- X-offset design to adjust diameter size on turning machines and optimise tolerances on machining centres.

Drill Fix DFSP

- Combines the benefits of a trigon-style DFT inboard and a square-style SP.X outboard insert.
- Standard diameter range from 14–55mm (.551–2.125") in 2 x D, 3 x D, 4 x D, and new 5 x D.
- Squared-outboard insert has four economic cutting edges.
- Highest feed rates and cutting speeds due to highly stable tool body design.
- X-offset design to adjust diameter size on turning machines and optimise tolerances on machining centres.
- Beyond™ grades to achieve highest productivity and outstanding results in steel, stainless steel, and cast iron.

Use where speed and economy
are prime considerations.



Drill Fix™ DFT™

- One drill system that covers a large diameter range, from 24–82mm (1.000–3.250") in 2.5 x D and 4 x D.
- Best centring capabilities due to trigon-shaped inserts used as inboard and outboard inserts.
- Various insert grades and geometries available.
- Balanced cutting forces in the shank centre for highest tool body stability.
- X-offset design to adjust diameter size on turning machines and optimise tolerances on machining centres.
- The Drill Fix DFT system has an inner insert for best centring capabilities.

■ **Stationary Applications**

Metric Drill Bodies with 2° Whistle Notch

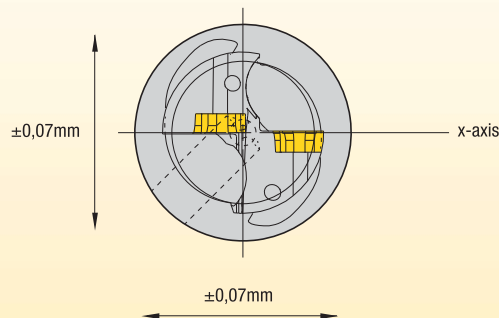

Metric shank drills with a 2° Whistle Notch shank are easily mounted into inch turrets using a WD adaptor. Align the X-axis of the drill with the X-axis of the machine tool as described above. Accurate alignment is absolutely essential for good performance. The drill must be on centre within the tolerance shown above. Angularity must not exceed 0,07mm.

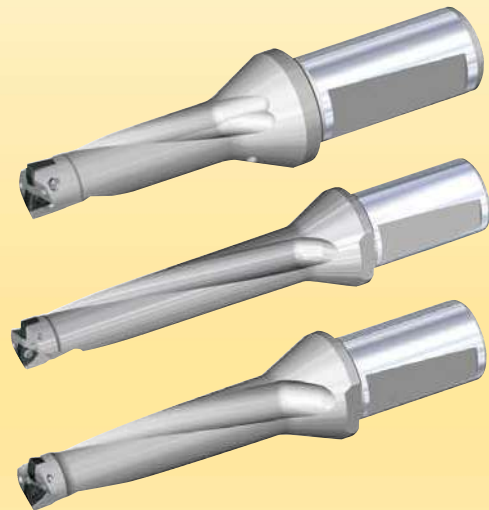

■ **Inch Bodies • Flange**

Drill Fix™ inch drills, with a flange, were designed for use on lathes or any machine where the tool remains stationary and the workpiece rotates. An “x” is marked on the flat of the X-axis of the drill to aid insert orientation on the machine tool.

It is important to align the X-axis of the drill with the X-axis on the machine tool. Accurate alignment is absolutely essential for good performance. The drill must be on centre, within the tolerance shown here. Angularity must not exceed 0,07mm within the designated drill depth.

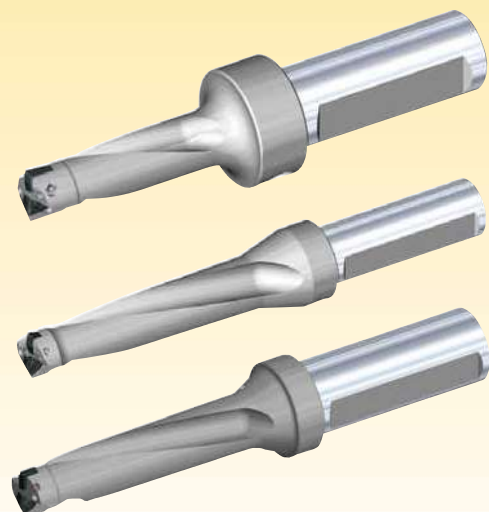

■ Drill Fix™ X-Adjustment

Application Examples

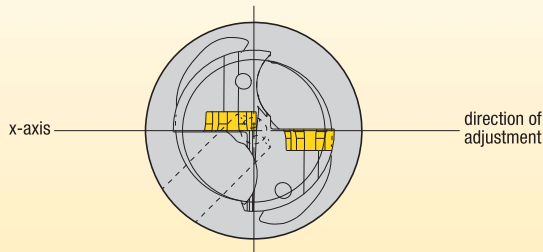

Stationary Tool

The X-adjustment must be made at the outer cutting edge, parallel to the surface of the outer insert when the turret of the turning machine is offset along the X-axis.

Rotating Tool • Straight Shank

Use an adjustable eccentric chuck with a steep taper to help offset the drill along the X-axis when machining with a rotating tool on a machining centre.

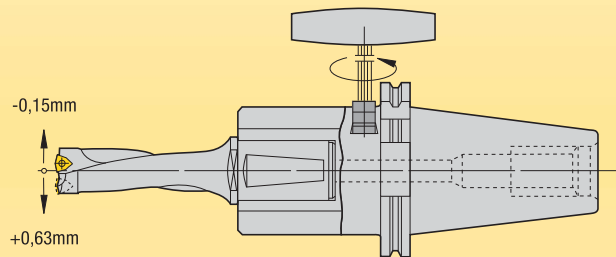

X-Adjustment Description

Different diameter holes can be drilled using the same Drill Fix drill. Holes with a diameter greater than the nominal diameter can be drilled directly into a solid. Intermediate dimensions are produced by means of the X-adjustment.

Benefits

- Eliminates the need for special tools for intermediate dimensions.
- Just a few drills cover a wide application range.
- Once precise adjustment of the desired diameter is made, tolerances of $\pm 0,05\text{mm}$ are achieved.

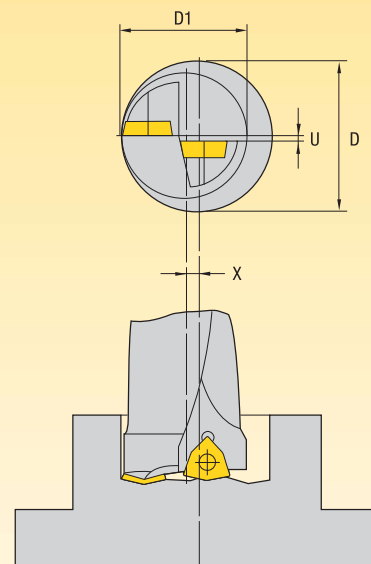

Additional information on X-adjustment, as well as additional information on Drill Fix tools, is available on the Kennametal website, kennametal.com.

➤ Drill Fix™ DFR™

The Drill Fix DFR platform offers maximum feed rates at a diameter range of 12,5–24mm (.500–1.000") for 2 x D, 3 x D, and 4 x D applications. Using rectangular-shaped inboard and outboard inserts enables soft starting cuts, short chips, and higher feed rates compared to small-size symmetrical-trigon or square inserts. The Drill Fix DFR platform's low cutting forces provide long tool life and high stability at the smallest diameters.

Features and Benefits

Productivity and Profitability

- Achieve high feed rates with rectangular-shaped inserts that offer a soft starting cut and greater stability.
- Use X-offset on turning machines to adjust drill, and eliminate the need for specials in many applications, and on machining centres to reach tolerance optimisation.
- Same insert size is used in each pocket, reducing inventory costs.

Versatility

- Diameter range covering 12,5–24mm (.500-1.000").
- 2 x D, 3 x D, and 4 x D L/D ratios as standard.
- Various shanks as standard available: WD, SSF, and new WB, a Weldon® shank.
- Multiple insert grades and geometries available.
- Use where feed rates are the limiting factor.
- Apply in straight holes, inclined entries and exits, interrupted cuts, and rough or welded entry surfaces.
- Eccentric chuck available as standard.

Low cutting forces provide long tool body life and high stability at the smallest diameters.



Reliability

- High stability in smaller sizes due to rectangular-shaped insert.
- Same insert can be used as inboard or outboard insert. No risk of mixing up inner and outer inserts.
- Low cutting forces result in long body tool life.

Customisation

- Intermediate diameters available as semi-standards.
- Engineered solutions available.
- Multistep drills available upon request.
- Left-hand version available.

- Drill shipped with insert screws and Torx wrench.
- See pages J84–J85 for inserts.

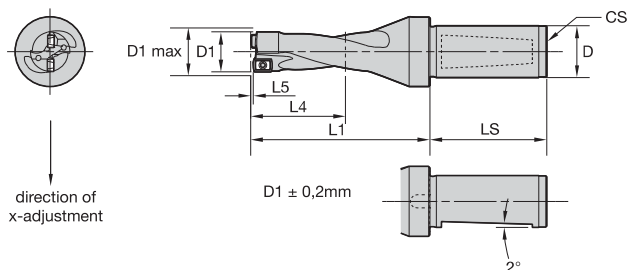
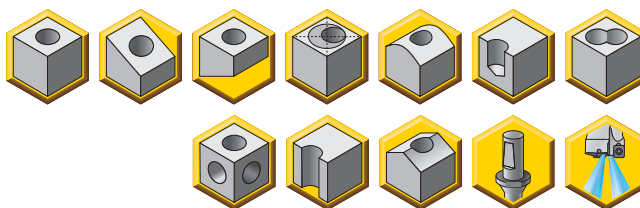

WN/WD Shank • 2 x D • Metric

D		D1	D1 max	L1	L4 max	L5	gage insert
20	32						
DFR125R2WD20M	—	12,50	13,50	47,4	25,0	0,5	DFR0202..
DFR127R2WD20M	—	12,70	13,70	47,8	25,4	0,5	DFR0202..
DFR130R2WD20M	—	13,00	14,00	48,4	26,0	0,5	DFR0202..
DFR135R2WD20M	—	13,50	14,50	49,4	27,0	0,5	DFR0202..
DFR140R2WD20M	—	14,00	15,00	50,4	28,0	0,5	DFR0202..
DFR145R2WD20M	—	14,50	15,50	53,4	29,0	0,5	DFR0202..
DFR150R2WD20M	—	15,00	16,00	54,4	30,0	0,5	DFR0202..
DFR155R2WD20M	—	15,50	16,50	55,4	31,0	0,5	DFR0202..
DFR160R2WD20M	—	16,00	17,00	56,4	32,0	0,5	DFR0202..
—	DFR165R2WD32M	16,50	17,50	62,4	33,0	0,6	DFR0302..
—	DFR170R2WD32M	17,00	18,00	63,4	34,0	0,6	DFR0302..
—	DFR175R2WD32M	17,50	18,50	64,4	35,0	0,6	DFR0302..
—	DFR180R2WD32M	18,00	19,00	65,4	36,0	0,6	DFR0302..
—	DFR185R2WD32M	18,50	19,50	66,4	37,0	0,6	DFR0302..
—	DFR190R2WD32M	19,00	20,00	67,4	38,0	0,6	DFR0302..
—	DFR195R2WD32M	19,50	20,50	68,4	39,0	0,6	DFR0302..
—	DFR200R2WD32M	20,00	21,00	72,4	40,0	0,6	DFR0302..
—	DFR205R2WD32M	20,50	21,50	73,6	41,0	0,8	DFR0403..
—	DFR210R2WD32M	21,00	22,00	74,6	42,0	0,8	DFR0403..
—	DFR220R2WD32M	22,00	23,00	76,6	44,0	0,8	DFR0403..
—	DFR230R2WD32M	23,00	24,00	78,6	46,0	0,8	DFR0403..
—	DFR240R2WD32M	24,00	25,00	80,6	48,0	0,8	DFR0403..

WARNING

During through-hole operations, a slug or disc is produced as the tool breaks through the workpiece. When the drill is stationary and the workpiece is rotating, this slug may be hurled from the chuck by centrifugal force. Provide adequate shielding to protect bystanders.



gage insert	insert screw	Torx wrench	Torx size
DFR0202..	193.281	170.027	6
DFR0302..	192.416	170.023	7
DFR0403..	192.432	170.028	8

D	LS	CS
20	45	R 1/8 BSP
32	58	R 1/4 BSP

- Drill shipped with insert screws and Torx wrench.
- See pages J84–J85 for inserts.

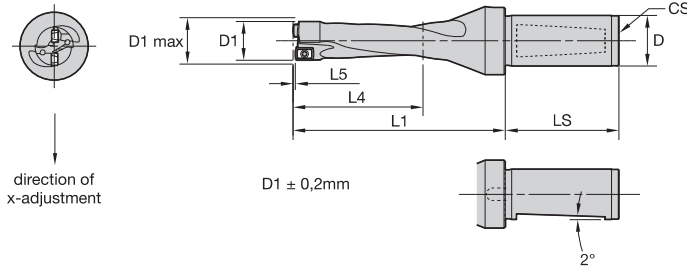
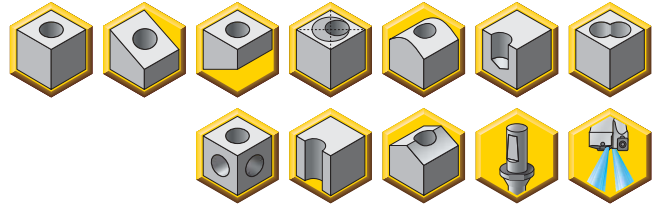

■ WN/WD Shank • 3 x D • Metric

D				D1	D1 max	L1	L4 max	L5	gage insert
20	25	32							
DFR125R3WD20M	—	—		12,50	13,50	59,9	37,5	0,5	DFR0202..
DFR127R3WD20M	—	—		12,70	13,70	60,5	38,1	0,5	DFR0202..
DFR130R3WD20M	—	—		13,00	14,00	61,4	39,0	0,5	DFR0202..
DFR135R3WD20M	—	—		13,50	14,50	62,9	40,5	0,5	DFR0202..
DFR140R3WD20M	—	—		14,00	15,00	64,4	42,0	0,5	DFR0202..
DFR145R3WD20M	—	—		14,50	15,50	67,9	43,5	0,5	DFR0202..
DFR150R3WD20M	—	—		15,00	16,00	69,4	45,0	0,5	DFR0202..
DFR155R3WD20M	—	—		15,50	16,50	70,9	46,5	0,5	DFR0202..
DFR160R3WD20M	—	—		16,00	17,00	72,4	48,0	0,5	DFR0202..
—	—	DFR165R3WD32M		16,50	17,50	78,9	49,5	0,6	DFR0302..
—	—	DFR170R3WD32M		17,00	18,00	80,4	51,0	0,6	DFR0302..
—	DFR175R3WD25M	DFR175R3WD32M		17,50	18,50	81,9	52,5	0,6	DFR0302..
—	DFR180R3WD25M	DFR180R3WD32M		18,00	19,00	83,4	54,0	0,6	DFR0302..
—	DFR185R3WD25M	DFR185R3WD32M		18,50	19,50	84,9	55,5	0,6	DFR0302..
—	DFR190R3WD25M	DFR190R3WD32M		19,00	20,00	86,4	57,0	0,6	DFR0302..
—	DFR195R3WD25M	DFR195R3WD32M		19,50	20,50	87,9	58,5	0,6	DFR0302..
—	DFR200R3WD25M	DFR200R3WD32M		20,00	21,00	92,4	60,0	0,6	DFR0302..
—	DFR205R3WD25M	DFR205R3WD32M		20,50	21,50	94,1	61,5	0,8	DFR0403..
—	DFR210R3WD25M	DFR210R3WD32M		21,00	22,00	95,6	63,0	0,8	DFR0403..
—	DFR220R3WD25M	DFR220R3WD32M		22,00	23,00	98,6	66,0	0,8	DFR0403..
—	DFR230R3WD25M	DFR230R3WD32M		23,00	24,00	101,6	69,0	0,8	DFR0403..
—	DFR240R3WD25M	DFR240R3WD32M		24,00	25,00	104,6	72,0	0,8	DFR0403..

WARNING
 During through-hole operations, a slug or disc is produced as the tool breaks through the workpiece. When the drill is stationary and the workpiece is rotating, this slug may be hurled from the chuck by centrifugal force. Provide adequate shielding to protect bystanders.



gage insert	insert screw	Torx wrench	Torx size
DFR0202..	193.281	170.027	6
DFR0302..	192.416	170.023	7
DFR0403..	192.432	170.028	8

D	LS	CS
20	45	R 1/8 BSP
25	45	R 1/4 BSP
32	58	R 1/4 BSP

- Drill shipped with insert screws and Torx wrench.
- See pages J84–J85 for inserts.

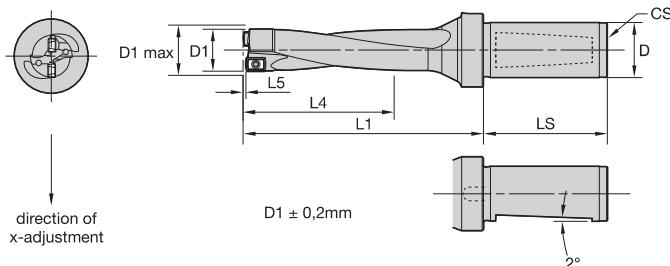
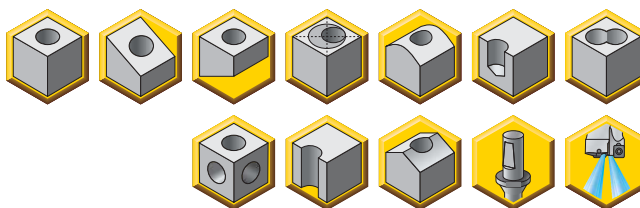

■ **WN/WD Shank • 4 x D • Metric**

	D		D1	D1 max	L1	L4 max	L5	gage insert
	20							
		32						
DFR125R4WD20M		—	12,50	13,50	72,4	50,0	0,5	DFR0202..
DFR127R4WD20M		—	12,70	13,70	73,2	50,8	0,5	DFR0202..
DFR130R4WD20M		—	13,00	14,00	74,4	52,0	0,5	DFR0202..
DFR135R4WD20M		—	13,50	14,50	76,4	54,0	0,5	DFR0202..
DFR140R4WD20M		—	14,00	15,00	78,4	56,0	0,5	DFR0202..
DFR145R4WD20M		—	14,50	15,50	82,4	58,0	0,5	DFR0202..
DFR150R4WD20M		—	15,00	16,00	84,4	60,0	0,5	DFR0202..
DFR155R4WD20M		—	15,50	16,50	86,4	62,0	0,5	DFR0202..
DFR160R4WD20M		—	16,00	17,00	88,4	64,0	0,5	DFR0202..
—		DFR165R4WD32M	16,50	17,50	95,4	66,0	0,6	DFR0302..
—		DFR170R4WD32M	17,00	18,00	97,4	68,0	0,6	DFR0302..
—		DFR175R4WD32M	17,50	18,50	99,4	70,0	0,6	DFR0302..
—		DFR180R4WD32M	18,00	19,00	101,4	72,0	0,6	DFR0302..
—		DFR185R4WD32M	18,50	19,50	103,4	74,0	0,6	DFR0302..
—		DFR190R4WD32M	19,00	20,00	105,4	76,0	0,6	DFR0302..
—		DFR195R4WD32M	19,50	20,50	107,4	78,0	0,6	DFR0302..
—		DFR200R4WD32M	20,00	21,00	109,4	80,0	0,6	DFR0302..
—		DFR205R4WD32M	20,50	21,50	111,6	82,0	0,8	DFR0403..
—		DFR210R4WD32M	21,00	22,00	113,6	84,0	0,8	DFR0403..
—		DFR220R4WD32M	22,00	23,00	117,6	88,0	0,8	DFR0403..
—		DFR230R4WD32M	23,00	24,00	121,6	92,0	0,8	DFR0403..
—		DFR240R4WD32M	24,00	25,00	125,6	96,0	0,8	DFR0403..

WARNING

During through-hole operations, a slug or disc is produced as the tool breaks through the workpiece. When the drill is stationary and the workpiece is rotating, this slug may be hurled from the chuck by centrifugal force. Provide adequate shielding to protect bystanders.



gage insert	insert screw	Torx wrench	Torx size
DFR0202..	193.281	170.027	6
DFR0302..	192.416	170.023	7
DFR0403..	192.432	170.028	8

D	LS	CS
20	45	R 1/8 BSP
32	58	R 1/4 BSP

- Drill shipped with insert screws and Torx wrench.
- See pages J84–J85 for inserts.

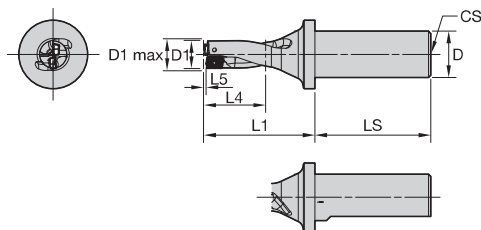
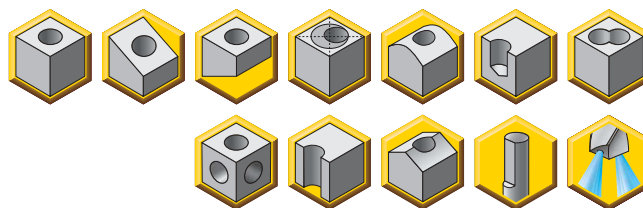

■ **Weldon® Shank • DIN 1835-1 Form B • 2 x D • Metric**

D	D1	D1 max	L1	L4 max	L5	gage insert
20						
DFR125R2WB20M	12,50	13,50	47,0	25,0	0,5	DFR0202..
DFR127R2WB20M	12,70	13,70	47,4	25,0	0,5	DFR0202..
DFR130R2WB20M	13,00	14,00	48,0	26,0	0,5	DFR0202..
DFR135R2WB20M	13,50	14,50	49,0	27,0	0,5	DFR0202..
DFR140R2WB20M	14,00	15,00	50,0	28,0	0,5	DFR0202..
DFR145R2WB20M	14,50	15,50	53,0	29,0	0,5	DFR0202..
DFR150R2WB20M	15,00	16,00	54,0	30,0	0,5	DFR0202..
DFR155R2WB20M	15,50	16,50	55,0	31,0	0,5	DFR0202..
DFR160R2WB20M	16,00	17,00	56,0	32,0	0,5	DFR0202..
DFR165R2WB20M	16,50	17,50	62,0	33,0	0,6	DFR0302..
DFR170R2WB20M	17,00	18,00	63,0	34,0	0,6	DFR0302..

NOTE for D1 max: Diameter can be adjusted. It is highly recommended to not adjust the diameter more than +1mm.

■ **Spare Parts**



gage insert	insert screw	Torx wrench	Torx size
DFR0202..	193.281	170.027	6
DFR0302..	192.416	170.023	7

WARNING

During through-hole operations, a slug or disc is produced as the tool breaks through the workpiece. When the drill is stationary and the workpiece is rotating, this slug may be hurled from the chuck by centrifugal force. Provide adequate shielding to protect bystanders.

D	LS	CS
20	50	R 1/8 BSP

- Drill shipped with insert screws and Torx wrench.
- See pages J84–J85 for inserts.

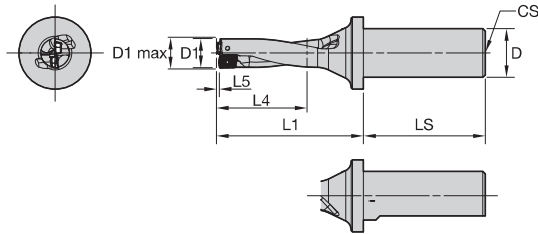
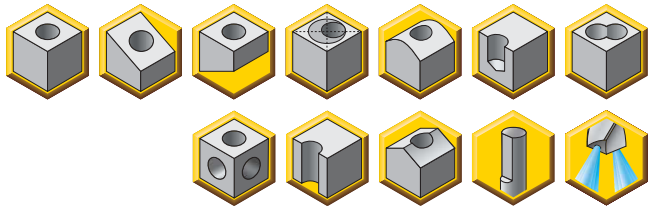

Indexable Drills

■ **Weldon® Shank • DIN 1835-1 Form B • 3 x D • Metric**

D	D1	D1 max	L1	L4 max	L5	gage insert
20						
DFR125R3WB20M	12,50	13,50	59,5	37,5	0,5	DFR0202..
DFR127R3WB20M	12,70	13,70	60,5	38,1	0,5	DFR0202..
DFR130R3WB20M	13,00	14,00	61,0	39,0	0,5	DFR0202..
DFR135R3WB20M	13,50	14,50	62,5	40,5	0,5	DFR0202..
DFR140R3WB20M	14,00	15,00	64,0	42,0	0,5	DFR0202..
DFR145R3WB20M	14,50	15,50	67,5	43,5	0,5	DFR0202..
DFR150R3WB20M	15,00	16,00	69,0	45,0	0,5	DFR0202..
DFR155R3WB20M	15,50	16,50	70,5	46,5	0,5	DFR0202..
DFR160R3WB20M	16,00	17,00	72,0	48,0	0,5	DFR0202..
DFR165R3WB20M	16,50	17,50	78,5	49,5	0,6	DFR0302..
DFR170R3WB20M	17,00	18,00	80,0	51,0	0,6	DFR0302..

NOTE for D1 max: Diameter can be adjusted. It is highly recommended to not adjust the diameter more than +1mm.

■ **Spare Parts**



gage insert	insert screw	Torx wrench	Torx size
DFR0202..	193.281	170.027	6
DFR0302..	192.416	170.023	7

WARNING

During through-hole operations, a slug or disc is produced as the tool breaks through the workpiece. When the drill is stationary and the workpiece is rotating, this slug may be hurled from the chuck by centrifugal force. Provide adequate shielding to protect bystanders.

D	LS	CS
20	50	R 1/8 BSP

- Drill shipped with insert screws and Torx wrench.
- See pages J84–J85 for inserts.

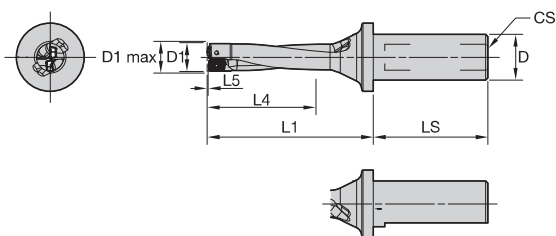
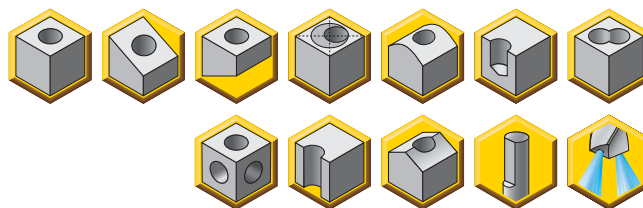

■ **Weldon® Shank • DIN 1835-1 Form B • 4 x D • Metric**

D	D1	D1 max	L1	L4 max	L5	gage insert
20						
DFR125R4WB20M	12,50	13,50	72,0	50,0	0,5	DFR0202..
DFR127R4WB20M	12,70	13,70	72,8	50,8	0,5	DFR0202..
DFR130R4WB20M	13,00	14,00	74,0	52,0	0,5	DFR0202..
DFR135R4WB20M	13,50	14,50	76,0	54,0	0,5	DFR0202..
DFR140R4WB20M	14,00	15,00	78,0	56,0	0,5	DFR0202..
DFR145R4WB20M	14,50	15,50	82,0	58,0	0,5	DFR0202..
DFR150R4WB20M	15,00	16,00	84,0	60,0	0,5	DFR0202..
DFR155R4WB20M	15,50	16,50	86,0	62,0	0,5	DFR0202..
DFR160R4WB20M	16,00	17,00	88,0	64,0	0,5	DFR0202..
DFR165R4WB20M	16,50	17,50	95,0	66,0	0,5	DFR0302..
DFR170R4WB20M	17,00	18,00	97,0	68,0	0,6	DFR0302..

NOTE for D1 max: Diameter can be adjusted. It is highly recommended to not adjust the diameter more than +1mm.

■ **Spare Parts**



gage insert	insert screw	Torx wrench	Torx size
DFR0202..	193.281	170.027	6
DFR0302..	192.416	170.023	7

WARNING

During through-hole operations, a slug or disc is produced as the tool breaks through the workpiece. When the drill is stationary and the workpiece is rotating, this slug may be hurled from the chuck by centrifugal force. Provide adequate shielding to protect bystanders.

D	LS	CS
20	50	R 1/8 BSP

■ Drill Fix™ DFR™ • Metric



					Metric							
Material Group	Condition	Pocket Seat	Geometry	Grade	Cutting Speed – vc			Recommended Feed Rate (fz) by Diameter				
					Range – m/min			Ø	DFR02... 12,50–16,00mm	DFR03... 16,50–20,00mm	DFR04... 20,50–24,00mm	
					min	Starting Value	max					
P	1	S	O	MD	KCU25	310	325	360	mm/r	0,09–0,15	0,11–0,18	0,15–0,25
			I	MD	KC7140							
		U	O	MD	KCU40	200	215	230	mm/r	0,09–0,15	0,11–0,18	0,15–0,25
			I	MD	KC7140							
		I	O	MD	KC7140	130	135	150	mm/r	0,09–0,15	0,11–0,18	0,15–0,25
			I	MD	KC7140							
	2	S	O	GD	KCPK10	310	325	360	mm/r	0,09–0,15	0,11–0,18	0,15–0,25
			I	LD	KC7140							
		U	O	GD	KCU40	200	215	230	mm/r	0,09–0,15	0,11–0,18	0,15–0,25
			I	LD	KC7140							
		I	O	MD	KC7140	130	135	150	mm/r	0,09–0,15	0,11–0,18	0,15–0,25
			I	LD	KC7140							
	3	S	O	GD	KCPK10	260	285	320	mm/r	0,09–0,15	0,11–0,18	0,15–0,25
			I	LD	KC7140							
		U	O	GD	KCU40	180	195	220	mm/r	0,09–0,15	0,11–0,18	0,15–0,25
			I	LD	KC7140							
		I	O	GD	KC7140	110	120	140	mm/r	0,09–0,15	0,11–0,18	0,15–0,25
			I	LD	KC7140							
	4	S	O	GD	KCU25	220	250	300	mm/r	0,09–0,15	0,11–0,18	0,15–0,25
			I	LD	KC7140							
		U	O	GD	KCU40	150	180	220	mm/r	0,09–0,15	0,11–0,18	0,15–0,25
			I	LD	KC7140							
		I	O	GD	KC7140	90	110	140	mm/r	0,09–0,15	0,11–0,18	0,15–0,25
			I	LD	KC7140							
5	S	O	GD	KCU25	180	200	220	mm/r	0,07–0,13	0,09–0,15	0,11–0,18	
		I	LD	KC7140								
	U	O	GD	KCU40	120	135	150	mm/r	0,07–0,13	0,09–0,15	0,11–0,18	
		I	LD	KC7140								
	I	O	GD	KC7140	70	85	100	mm/r	0,07–0,13	0,09–0,15	0,11–0,18	
		I	LD	KC7140								
6	S	O	GD	KCU25	180	200	220	mm/r	0,07–0,13	0,09–0,15	0,11–0,18	
		I	LD	KC7140								
	U	O	GD	KCU40	120	135	150	mm/r	0,07–0,13	0,09–0,15	0,11–0,18	
		I	LD	KC7140								
	I	O	GD	KC7140	70	85	100	mm/r	0,07–0,13	0,09–0,15	0,11–0,18	
		I	LD	KC7140								
M	1	S	O	MD	KC7140	150	190	230	mm/r	0,07–0,13	0,08–0,16	0,10–0,18
			I	MD	KC7140							
		U	O	MD	KC7140	100	130	160	mm/r	0,07–0,13	0,08–0,16	0,10–0,18
			I	MD	KC7140							
		I	O	MD	KC7140	60	80	100	mm/r	0,07–0,13	0,08–0,16	0,10–0,18
			I	MD	KC7140							
	2	S	O	MD	KC7140	150	180	210	mm/r	0,07–0,13	0,08–0,16	0,10–0,18
			I	MD	KC7140							
		U	O	MD	KC7140	100	130	160	mm/r	0,07–0,13	0,08–0,16	0,10–0,18
			I	MD	KC7140							
		I	O	MD	KC7140	60	80	100	mm/r	0,07–0,13	0,08–0,16	0,10–0,18
			I	MD	KC7140							
3	S	O	MD	KC7140	100	130	160	mm/r	0,07–0,13	0,08–0,16	0,10–0,18	
		I	MD	KC7140								
	U	O	MD	KC7140	80	110	140	mm/r	0,07–0,13	0,08–0,16	0,10–0,18	
		I	MD	KC7140								
	I	O	MD	KC7140	50	70	90	mm/r	0,07–0,13	0,08–0,16	0,10–0,18	
		I	MD	KC7140								

Condition: S = Stable cutting conditions;
 U = Unstable cutting conditions;
 I = Interrupted cutting conditions

Pocket seat: I = Inboard insert;
 O = Outboard insert

Drill Fix™ DFR™ • Metric

		Metric										
Material Group	Condition	Pocket Seat	Geometry	Grade	Cutting Speed – vc			Recommended Feed Rate (fz) by Diameter				
					Range – m/min			Ø	DFR02... 12,50–16,00mm	DFR03... 16,50–20,00mm	DFR04... 20,50–24,00mm	
					min	Starting Value	max					
K	1	S	O	GD	KCPK10	200	240	300	mm/r	0,10–0,18	0,12–0,20	0,14–0,24
			I	LD	KCU40							
		U	O	GD	KCU25	120	155	200	mm/r	0,10–0,18	0,12–0,20	0,14–0,24
	I		LD	KC7140								
	2	S	O	GD	KCPK10	180	220	260	mm/r	0,10–0,18	0,12–0,20	0,14–0,24
			I	LD	KCU40							
		U	O	GD	KCU25	110	140	170	mm/r	0,10–0,18	0,12–0,20	0,14–0,24
	I		LD	KC7140								
	3	S	O	GD	KCPK10	180	220	260	mm/r	0,10–0,18	0,12–0,20	0,14–0,24
			I	LD	KCU40							
		U	O	GD	KCU25	110	140	170	mm/r	0,10–0,18	0,12–0,20	0,14–0,24
	I		LD	KC7140								
N	1	S	O	ST	KD1425	400	600	800	mm/r	0,07–0,09	0,10–0,14	0,12–0,16
			I	LD	KCU40							
		U	O	LD	KCU40	300	400	500	mm/r	0,07–0,09	0,10–0,14	0,12–0,16
	I		LD	KCU40								
	2	S	O	ST	KD1425	375	550	775	mm/r	0,07–0,09	0,10–0,14	0,12–0,16
			I	LD	KCU40							
		U	O	LD	KCU40	250	350	450	mm/r	0,07–0,09	0,10–0,14	0,12–0,16
	I		LD	KCU40								
	3	S	O	ST	KD1425	350	500	650	mm/r	0,07–0,09	0,10–0,14	0,12–0,16
			I	LD	KCU40							
		U	O	LD	KCU40	250	350	450	mm/r	0,07–0,09	0,10–0,14	0,12–0,16
	I		LD	KCU40								
	4	S	O	ST	KD1425	400	600	800	mm/r	0,07–0,09	0,10–0,14	0,12–0,16
			I	LD	KCU40							
		U	O	LD	KCU40	250	350	450	mm/r	0,07–0,09	0,10–0,14	0,12–0,16
	I		LD	KCU40								
	5	S	O	ST	KD1425	400	600	800	mm/r	0,07–0,09	0,10–0,14	0,12–0,16
			I	LD	KCU40							
		U	O	LD	KCU40	250	350	450	mm/r	0,07–0,09	0,10–0,14	0,12–0,16
	I		LD	KCU40								
	6	S	O	ST	KD1425	400	600	800	mm/r	0,07–0,09	0,10–0,14	0,12–0,16
			I	LD	KCU40							
		U	O	GD	KCU40	250	350	450	mm/r	0,07–0,09	0,10–0,14	0,12–0,16
	I		LD	KCU40								
												O
I	LD	KCU40										

Condition: S = Stable cutting conditions;
 U = Unstable cutting conditions;
 I = Interrupted cutting conditions

Pocket seat: I = Inboard insert;
 O = Outboard insert

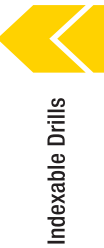

■ Drill Fix™ DFR™ • Metric

Indexable Drills

Metric												
Material Group	Condition	Pocket Seat	Geometry	Grade	Cutting Speed – vc			Recommended Feed Rate (fz) by Diameter				
					Range – m/min			Ø	DFR02... 12,50–16,00mm	DFR03... 16,50–20,00mm	DFR04... 20,50–24,00mm	
					min	Starting Value	max					
S	1	S	O	GD	KCU40	60	70	75	mm/r	0,04–0,06	0,05–0,08	0,06–0,10
			I	LD	KCU40							
	U	O	GD	KCU40	40	50	60	mm/r	0,04–0,06	0,05–0,08	0,06–0,10	
		I	LD	KC7140								
	I	O	MD	KC7140	25	30	40	mm/r	0,04–0,06	0,05–0,08	0,06–0,10	
		I	MD	KC7140								
	2	S	O	GD	KCU40	50	60	70	mm/r	0,04–0,06	0,05–0,08	0,06–0,10
			I	LD	KCU40							
		U	O	GD	KCU40	30	40	50	mm/r	0,04–0,06	0,05–0,08	0,06–0,10
			I	LD	KC7140							
		I	O	MD	KC7140	25	30	40	mm/r	0,04–0,06	0,05–0,08	0,06–0,10
			I	MD	KC7140							
	3	S	O	GD	KCU40	70	80	90	mm/r	0,05–0,08	0,06–0,10	0,06–0,10
			I	LD	KCU40							
		U	O	GD	KCU40	50	60	70	mm/r	0,05–0,08	0,06–0,10	0,06–0,10
			I	LD	KC7140							
		I	O	MD	KC7140	30	40	50	mm/r	0,05–0,08	0,06–0,10	0,06–0,10
			I	MD	KC7140							
	4	S	O	GD	KCU40	70	80	90	mm/r	0,05–0,08	0,06–0,10	0,06–0,10
			I	LD	KCU40							
		U	O	GD	KCU40	50	60	70	mm/r	0,05–0,08	0,06–0,10	0,06–0,10
			I	LD	KC7140							
		I	O	MD	KC7140	30	40	50	mm/r	0,05–0,08	0,06–0,10	0,06–0,10
			I	MD	KC7140							

Condition: S = Stable cutting conditions;
 U = Unstable cutting conditions;
 I = Interrupted cutting conditions

Pocket seat: I = Inboard insert;
 O = Outboard insert

NOVO KNOWS SEARCH

Searching for a tool has been enhanced by Advise and Select functions from NOVO™ applications — saving you time and money.

ADVISE

Uses a rules-based approach to provide cutting tool recommendations:

- Define Machining Feature (face milling, slotting, blind hole, etc.)
- Apply Constraint Requirements (geometric, material, tolerance, etc.)
- Set Machining Sequence (single or multi-step operations, rough then finish, etc.)
- Receive Ranked Results

SELECT

A method of selecting cutting tools from a tree structure via a hierarchy or parametric search:

- If you know which product you are looking for, a quick search can be performed by just the catalogue number or product description.
- Smart filters significantly reduce the amount of potential tooling solutions.
- After the tool is selected, NOVO also provides cutting and adaptive item options that fit with your solution.

NOVO applications can ensure you have the right tools on your machines, in the right sequence. Resulting in flawless execution that accelerates every job, and maximises every shift. kennametal.com/novo

➤ Drill Fix™ DFSP™

DFSP is the new name of the now-extended Drill Fix DFS™ indexable drilling platform. The standard diameter range is now expanded starting from 14–55mm (.551–2.125") in L/D ratios 2 x D, 3 x D, 4 x D, and 5 x D. Like the DFS platform, the DFSP platform combines the economically squared outboard insert with the superior centring capabilities of the trigon inboard insert. DFSP indexable drills offer increased metal removal rates combined with high surface quality and hole straightness.

Boost your productivity even further and achieve outstanding results in steel, stainless steel, and cast iron with the latest Beyond™ insert grades.

Features and Benefits

Higher Productivity and Profitability

- Achieve highest metal removal rates and excellent chip evacuation from advanced chip flutes and non-central and increased cooling channels.
- Squared outboard inserts offer four economic cutting edges.
- Complete product portfolio offers standard L/D ratios up to 5 x D.

Versatility

- Drill holes up to 5 x D in steel, cast iron, ductile iron, stainless steel, and non-ferrous materials.
- Use where speed and economy are prime considerations.
- Use DFSP drills in straight holes, inclined entries and exits, interrupted cuts, and rough or welded entry surfaces.
- Use X-offset on turning machines to adjust the drill diameter and eliminate the need for specials in many applications, and on machining centres to reach tolerance optimisation.
- Eccentric chuck available as standard.
- Quick and easy insert grade and/or geometry change to address material and application changes.

Boost your productivity even further with the latest Beyond™ insert grades.



Reliability

- High accuracy holes in any feed rates.
- Gain outstanding results using Beyond grades for DFT™ and SPGX/SPPX inserts.
- High wear resistance in interrupted cuts due to squared outboard insert.

Customisation

- Use DFSP cartridges to extend diameter range up to 85mm (3.35") in L/D ratios up to 5 x D.
- Intermediate diameters, multistep drills, and other non-standard shanks are available.
- Contact our engineered solutions team for recommendations.

- DFSP combines the economical squared outboard insert with the superior centring capabilities of the trigon inboard insert.
- Drill shipped with insert screws and Torx wrench.
- Order inserts for DFSP separately.
See pages J89–J90 for inserts.

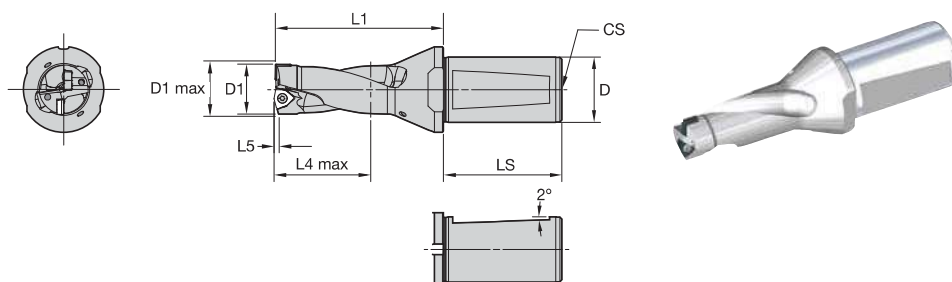
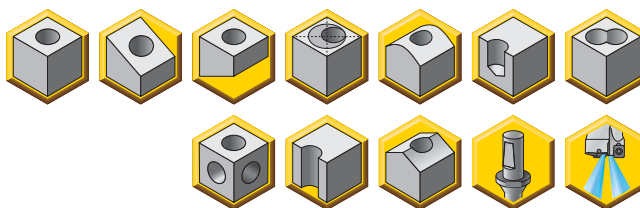

■ WD Shank • 2 x D • Metric

		D										
		20	32	40	50	D1	D1 max	L1	L4 max	L5	gage insert outside	gage insert inside
	DFSP140R2WD20M	—	—	—	—	14,00	15,00	50,0	28,0	0,3	SPGX0502..	DFTX202..
	DFSP145R2WD20M *	—	—	—	—	14,50	15,50	53,0	29,0	0,4	SPGX0502..	DFTX202..
	DFSP150R2WD20M	—	—	—	—	15,00	16,00	54,0	30,0	0,4	SPGX0502..	DFTX202..
	DFSP155R2WD20M	—	—	—	—	15,50	16,50	55,0	31,0	0,4	SPGX0502..	DFTX202..
	DFSP160R2WD20M	—	—	—	—	16,00	17,00	56,0	32,0	0,4	SPGX0502..	DFTX202..
	—	DFSP165R2WD32M	—	—	—	16,50	17,50	62,0	33,0	0,5	SPGX0502..	DFTX202..
	—	DFSP170R2WD32M	—	—	—	17,00	18,00	63,0	34,0	0,5	SPGX0502..	DFTX202..
	—	DFSP175R2WD32M	—	—	—	17,50	18,50	64,0	35,0	0,5	SPGX0603..	DFT0303..
	—	DFSP180R2WD32M	—	—	—	18,00	19,00	65,0	36,0	0,5	SPGX0603..	DFT0303..
	—	DFSP185R2WD32M	—	—	—	18,50	19,50	66,0	37,0	0,6	SPGX0603..	DFT0303..
	—	DFSP190R2WD32M	—	—	—	19,00	20,00	67,0	38,0	0,6	SPGX0603..	DFT0303..
	—	DFSP195R2WD32M	—	—	—	19,50	20,50	68,0	39,0	0,6	SPGX0603..	DFT0303..
	—	DFSP200R2WD32M	—	—	—	20,00	21,00	72,0	40,0	0,6	SPGX0603..	DFT0303..
	—	DFSP210R2WD32M	—	—	—	21,00	22,00	74,0	42,0	0,7	SPGX0603..	DFT0303..
	—	DFSP220R2WD32M	—	—	—	22,00	23,00	76,0	44,0	0,5	SPGX0703..	DFT05T3..
	—	DFSP230R2WD32M	—	—	—	23,00	24,00	78,0	46,0	0,6	SPGX0703..	DFT05T3..
	—	DFSP240R2WD32M	—	—	—	24,00	25,00	80,0	48,0	0,6	SPGX0703..	DFT05T3..
	—	DFSP250R2WD32M	—	—	—	25,00	26,00	83,0	50,0	0,7	SPGX0703..	DFT05T3..
	—	DFSP260R2WD32M	—	—	—	26,00	27,00	86,0	52,0	0,7	SPPX09T3..	DFT05T3..
	—	DFSP265R2WD32M	—	—	—	26,50	27,50	87,0	53,0	0,7	SPPX09T3..	DFT05T3..
	—	DFSP270R2WD32M	—	—	—	27,00	28,00	89,0	54,0	0,8	SPPX09T3..	DFT05T3..
	—	DFSP280R2WD32M	—	—	—	28,00	29,00	91,0	56,0	0,8	SPPX09T3..	DFT05T3..
	—	DFSP290R2WD32M	—	—	—	29,00	30,00	94,0	58,0	0,9	SPPX09T3..	DFT05T3..
	—	DFSP300R2WD32M	—	—	—	30,00	31,00	97,0	60,0	0,9	SPPX09T3..	DFT05T3..
	—	DFSP310R2WD32M	—	—	—	31,00	32,00	100,0	62,0	0,9	SPPX09T3..	DFT05T3..
	—	DFSP320R2WD32M	—	—	—	32,00	33,00	103,0	64,0	1,0	SPPX09T3..	DFT05T3..
	—	DFSP330R2WD32M	—	—	—	33,00	34,00	105,0	66,0	0,9	SPPX1204..	DFT06T3..
	—	DFSP340R2WD32M	—	—	—	34,00	35,00	108,0	68,0	0,9	SPPX1204..	DFT06T3..
	—	DFSP350R2WD32M	—	—	—	35,00	36,00	111,0	70,0	1,0	SPPX1204..	DFT06T3..
	—	DFSP360R2WD32M	—	—	—	36,00	37,00	114,0	72,0	1,0	SPPX1204..	DFT06T3..
	—	DFSP370R2WD32M	—	—	—	37,00	38,00	117,0	74,0	1,1	SPPX1204..	DFT06T3..
	—	DFSP375R2WD32M *	—	—	—	37,50	38,50	118,0	75,0	1,1	SPPX1204..	DFT06T3..
	—	DFSP380R2WD32M	—	—	—	38,00	39,00	119,0	76,0	1,1	SPPX1204..	DFT06T3..
	—	DFSP390R2WD32M	—	—	—	39,00	40,00	122,0	78,0	1,2	SPPX1204..	DFT06T3..
	—	DFSP400R2WD32M	—	—	—	40,00	41,00	125,0	80,0	1,2	SPPX1204..	DFT06T3..
	—	DFSP410R2WD32M	—	—	—	41,00	42,00	128,0	82,0	1,2	SPPX1204..	DFT0704..

(continued)

(WD Shank • 2 x D • Metric — continued)

		D			D1	D1 max	L1	L4 max	L5	gage insert outside	gage insert inside
20	32	40	50								
—	DFSP420R2WD32M	—	—	42,00	43,00	131,0	84,0	1,3	SPPX1204..	DFT0704..	
—	DFSP430R2WD32M	—	—	43,00	44,00	133,0	86,0	1,3	SPPX1204..	DFT0704..	
—	DFSP440R2WD32M	—	—	44,00	45,00	135,0	88,0	1,4	SPPX15T5..	DFT0704..	
—	—	DFSP450R2WD40M	—	45,00	46,00	137,0	90,0	1,4	SPPX15T5..	DFT0704..	
—	—	DFSP460R2WD40M	—	46,00	47,00	140,0	92,0	1,5	SPPX15T5..	DFT0704..	
—	—	DFSP470R2WD40M	—	47,00	48,00	142,0	94,0	1,5	SPPX15T5..	DFT0704..	
—	—	DFSP480R2WD40M	—	48,00	49,00	144,0	96,0	1,5	SPPX15T5..	DFT0704..	
—	—	DFSP490R2WD40M	—	49,00	50,00	146,0	98,0	1,4	SPPX15T5..	DFT0905..	
—	—	DFSP500R2WD40M	—	50,00	51,00	148,0	100,0	1,5	SPPX15T5..	DFT0905..	
—	—	DFSP505R2WD40M	—	50,50	51,50	148,0	100,0	1,5	SPPX15T5..	DFT0905..	
—	—	DFSP510R2WD40M	—	51,00	52,00	150,0	102,0	1,6	SPPX15T5..	DFT0905..	
—	—	DFSP520R2WD40M	—	52,00	53,00	152,0	104,0	1,6	SPPX15T5..	DFT0905..	
—	—	DFSP530R2WD40M	—	53,00	54,00	154,0	106,0	1,7	SPPX15T5..	DFT0905..	
—	—	DFSP540R2WD40M	—	54,00	55,00	156,0	108,0	1,7	SPPX15T5..	DFT0905..	
—	—	—	DFSP550R2WD50M	55,00	56,00	158,0	110,0	1,8	SPPX15T5..	DFT0905..	

NOTE for D1 max: Diameter can be adjusted. It is highly recommended to not adjust the diameter more than +1mm.

NOTE: *Made-to-order standard item. Standard pricing, manufacturing lead time, and minimum order quantity applies.

Spare Parts



diameter range	gage insert inside	inboard insert screw	tightening torque Nm	gage insert outside	outboard insert screw	tightening torque Nm	Torx driver	Torx size
14.00–17.00	DFTX202..	193.281	0,6	SPGX0502..	193.281	0,6	170.370	T6
17.50–21.00	DFT0303..	MS1152	0,9	SPGX0603..	MS1152	0,9	170.023	T7
22.00–25.00	DFT05T3..	193.491	2,1	SPGX0703..	192.432	1,3	170.028	T8
26.00–32.00	DFT05T3..	191.924	2,1	SPPX09T3..	191.924	2,1	170.024	T9
33.00–40.00	DFT06T3..	191.916	4	SPPX1204..	191.916	4	170.025	T15
41.00–43.00	DFT0704..	191.916	6	SPPX1204..	191.916	3	170.025	T15
44.00–48.00	DFT0704..	191.698	6	SPPX15T5..	192.433	3	170.025	T15
49.00–55.00	DFT0905..	192.433	6	SPPX15T5..	192.433	6	170.025	T15

NOTE: To ensure proper clamping, two different screws for DFT™ inserts with different threads for diameter ranges 22–25,5mm and 41–48mm are necessary. Both screws have the same Torx size.

WARNING

During through-hole operations, a slug or disc is produced as the tool breaks through the workpiece. When the drill is stationary and the workpiece is rotating, this slug may be hurled from the chuck by centrifugal force. Provide adequate shielding to protect bystanders.

D	LS	CS
20	45	—
32	58	R 1/4 BSP
40	68	R 1/4 BSP
50	68	R 1/4 BSP



- DFSP combines the economical squared outboard insert with the superior centring capabilities of the trigon inboard insert.
- Drill shipped with insert screws and Torx wrench.
- Order inserts for DFSP separately.
See pages J89–J90 for inserts.

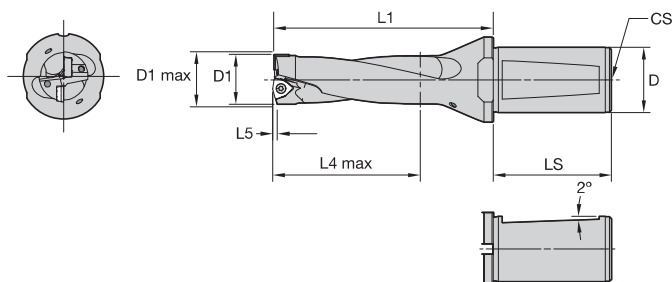
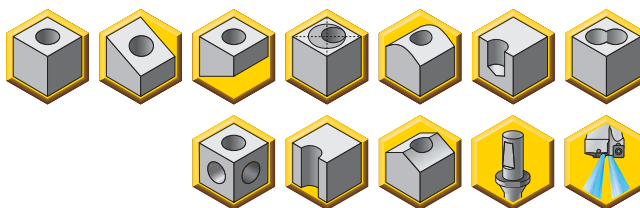

■ WD Shank • 3 x D • Metric

		D			D1		L1	L4 max	L5	gage insert outside	gage insert inside
20	32	40	50	D1	D1 max						
DFSP140R3WD20M	—	—	—	14,00	15,00	64,0	42,0	0,3	SPGX0502..	DFTX202..	
DFSP145R3WD20M	—	—	—	14,50	15,50	67,5	43,5	0,4	SPGX0502..	DFTX202..	
DFSP150R3WD20M	—	—	—	15,00	16,00	69,0	45,0	0,4	SPGX0502..	DFTX202..	
DFSP155R3WD20M	—	—	—	15,50	16,50	70,5	46,5	0,4	SPGX0502..	DFTX202..	
DFSP160R3WD20M	—	—	—	16,00	17,00	72,0	48,0	0,4	SPGX0502..	DFTX202..	
—	DFSP165R3WD32M	—	—	16,50	17,50	78,5	49,5	0,5	SPGX0502..	DFTX202..	
—	DFSP170R3WD32M	—	—	17,00	18,00	80,0	51,0	0,5	SPGX0502..	DFTX202..	
—	DFSP175R3WD32M	—	—	17,50	18,50	81,5	52,5	0,5	SPGX0603..	DFT0303..	
—	DFSP180R3WD32M	—	—	18,00	19,00	83,0	54,0	0,5	SPGX0603..	DFT0303..	
—	DFSP185R3WD32M	—	—	18,50	19,50	84,5	55,5	0,6	SPGX0603..	DFT0303..	
—	DFSP190R3WD32M	—	—	19,00	20,00	86,0	57,0	0,6	SPGX0603..	DFT0303..	
—	DFSP195R3WD32M	—	—	19,50	20,50	87,5	58,5	0,6	SPGX0603..	DFT0303..	
—	DFSP200R3WD32M	—	—	20,00	21,00	92,0	60,0	0,6	SPGX0603..	DFT0303..	
—	DFSP210R3WD32M	—	—	21,00	22,00	95,0	63,0	0,7	SPGX0603..	DFT0303..	
—	DFSP220R3WD32M	—	—	22,00	23,00	98,0	66,0	0,5	SPGX0703..	DFT05T3..	
—	DFSP230R3WD32M	—	—	23,00	24,00	101,0	69,0	0,6	SPGX0703..	DFT05T3..	
—	DFSP240R3WD32M	—	—	24,00	25,00	104,0	72,0	0,6	SPGX0703..	DFT05T3..	
—	DFSP250R3WD32M	—	—	25,00	26,00	108,0	75,0	0,7	SPGX0703..	DFT05T3..	
—	DFSP260R3WD32M	—	—	26,00	27,00	112,0	78,0	0,7	SPPX09T3..	DFT05T3..	
—	DFSP265R3WD32M	—	—	26,50	27,50	113,5	79,5	0,7	SPPX09T3..	DFT05T3..	
—	DFSP270R3WD32M	—	—	27,00	28,00	116,0	81,0	0,8	SPPX09T3..	DFT05T3..	
—	DFSP280R3WD32M	—	—	28,00	29,00	119,0	84,0	0,8	SPPX09T3..	DFT05T3..	
—	DFSP290R3WD32M	—	—	29,00	30,00	123,0	87,0	0,9	SPPX09T3..	DFT05T3..	
—	DFSP300R3WD32M	—	—	30,00	31,00	127,0	90,0	0,9	SPPX09T3..	DFT05T3..	
—	DFSP310R3WD32M	—	—	31,00	32,00	131,0	93,0	0,9	SPPX09T3..	DFT05T3..	
—	DFSP320R3WD32M	—	—	32,00	33,00	135,0	96,0	1,0	SPPX09T3..	DFT05T3..	
—	DFSP330R3WD32M	—	—	33,00	34,00	138,0	99,0	0,9	SPPX1204..	DFT06T3..	
—	DFSP340R3WD32M	—	—	34,00	35,00	142,0	102,0	0,9	SPPX1204..	DFT06T3..	
—	DFSP350R3WD32M	—	—	35,00	36,00	146,0	105,0	1,0	SPPX1204..	DFT06T3..	
—	DFSP360R3WD32M	—	—	36,00	37,00	150,0	108,0	1,0	SPPX1204..	DFT06T3..	
—	DFSP370R3WD32M	—	—	37,00	38,00	154,0	111,0	1,1	SPPX1204..	DFT06T3..	
—	DFSP375R3WD32M	—	—	37,50	38,50	155,5	112,5	1,1	SPPX1204..	DFT06T3..	
—	DFSP380R3WD32M	—	—	38,00	39,00	157,0	114,0	1,1	SPPX1204..	DFT06T3..	
—	DFSP390R3WD32M	—	—	39,00	40,00	161,0	117,0	1,2	SPPX1204..	DFT06T3..	
—	DFSP400R3WD32M	—	—	40,00	41,00	165,0	120,0	1,2	SPPX1204..	DFT06T3..	
—	DFSP410R3WD32M	—	—	41,00	42,00	169,0	123,0	1,2	SPPX1204..	DFT0704..	

(continued)

(WD Shank • 3 x D • Metric — continued)

20	D			D1	D1 max	L1	L4 max	L5	gage insert outside	gage insert inside
	32	40	50							
—	DFSP420R3WD32M	—	—	42,00	43,00	173,0	126,0	1,3	SPPX1204..	DFT0704..
—	DFSP430R3WD32M	—	—	43,00	44,00	176,0	129,0	1,3	SPPX1204..	DFT0704..
—	DFSP440R3WD32M	—	—	44,00	45,00	179,0	132,0	1,4	SPPX15T5..	DFT0704..
—	—	DFSP450R3WD40M	—	45,00	46,00	182,0	135,0	1,4	SPPX15T5..	DFT0704..
—	—	DFSP460R3WD40M	—	46,00	47,00	186,0	138,0	1,5	SPPX15T5..	DFT0704..
—	—	DFSP470R3WD40M	—	47,00	48,00	189,0	141,0	1,5	SPPX15T5..	DFT0704..
—	—	DFSP480R3WD40M	—	48,00	49,00	192,0	144,0	1,5	SPPX15T5..	DFT0704..
—	—	DFSP490R3WD40M	—	49,00	50,00	195,0	147,0	1,4	SPPX15T5..	DFT0905..
—	—	DFSP500R3WD40M	—	50,00	51,00	198,0	150,0	1,5	SPPX15T5..	DFT0905..
—	—	DFSP505R3WD40M	—	50,50	51,50	199,5	151,5	1,5	SPPX15T5..	DFT0905..
—	—	DFSP510R3WD40M	—	51,00	52,00	201,0	153,0	1,6	SPPX15T5..	DFT0905..
—	—	DFSP520R3WD40M	—	52,00	53,00	204,0	156,0	1,6	SPPX15T5..	DFT0905..
—	—	DFSP530R3WD40M	—	53,00	54,00	207,0	159,0	1,7	SPPX15T5..	DFT0905..
—	—	DFSP540R3WD40M	—	54,00	55,00	210,0	162,0	1,7	SPPX15T5..	DFT0905..
—	—	—	DFSP550R3WD50M	55,00	56,00	213,0	165,0	1,8	SPPX15T5..	DFT0905..

NOTE for D1 max: Diameter can be adjusted. It is highly recommended to not adjust the diameter more than +1mm.

Spare Parts



diameter range	gage insert inside	inboard insert screw	tightening torque Nm	gage insert outside	outboard insert screw	tightening torque Nm	Torx driver	Torx size
14.00–17.00	DFTX202..	193.281	0,6	SPGX0502..	193.281	0,6	170.370	T6
17.50–21.00	DFT0303..	MS1152	0,9	SPGX0603..	MS1152	0,9	170.023	T7
22.00–25.00	DFT05T3..	193.491	2,1	SPGX0703..	192.432	1,3	170.028	T8
26.00–32.00	DFT05T3..	191.924	2,1	SPPX09T3..	191.924	2,1	170.024	T9
33.00–40.00	DFT06T3..	191.916	4	SPPX1204..	191.916	4	170.025	T15
41.00–43.00	DFT0704..	191.916	6	SPPX1204..	191.916	3	170.025	T15
44.00–48.00	DFT0704..	191.698	6	SPPX15T5..	192.433	3	170.025	T15
49.00–55.00	DFT0905..	192.433	6	SPPX15T5..	192.433	6	170.025	T15

NOTE: To ensure proper clamping, two different screws for DFT™ inserts with different threads for diameter ranges 22–25mm and 41–48mm are necessary. Both screws have the same Torx size.

WARNING

During through-hole operations, a slug or disc is produced as the tool breaks through the workpiece. When the drill is stationary and the workpiece is rotating, this slug may be hurled from the chuck by centrifugal force. Provide adequate shielding to protect bystanders.

D	LS	CS
20	45	—
32	58	R 1/4 BSP
40	68	R 1/4 BSP
50	68	R 1/4 BSP



- DFSP combines the economical squared outboard insert with the superior centring capabilities of the trigon inboard insert.
- Drill shipped with insert screws and Torx wrench.
- Order inserts for DFSP separately.
See pages J89–J90 for inserts.

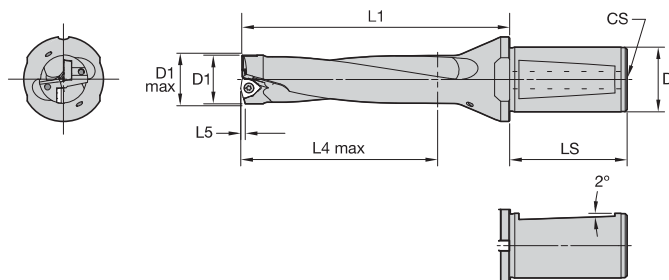
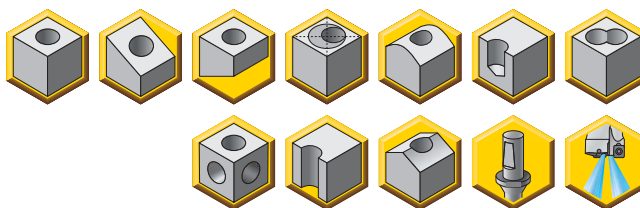

■ WD Shank • 4 x D • Metric

		D			D1		L1			L4 max		L5		gage insert outside	gage insert inside
20	32	40	50	D1	D1 max	L1	L4 max	L5	gage insert outside	gage insert inside					
DFSP140R4WD20M	—	—	—	14,00	15,00	78,0	56,0	0,3	SPGX0502..	DFTX202..					
DFSP145R4WD20M	—	—	—	14,50	15,50	82,0	58,0	0,4	SPGX0502..	DFTX202..					
DFSP150R4WD20M	—	—	—	15,00	16,00	84,0	60,0	0,4	SPGX0502..	DFTX202..					
DFSP155R4WD20M *	—	—	—	15,50	16,50	86,0	62,0	0,4	SPGX0502..	DFTX202..					
DFSP160R4WD20M	—	—	—	16,00	17,00	88,0	64,0	0,4	SPGX0502..	DFTX202..					
DFSP165R4WD20M *	—	—	—	16,50	17,50	95,0	66,0	0,5	SPGX0502..	DFTX202..					
DFSP170R4WD20M	—	—	—	17,00	18,00	97,0	68,0	0,5	SPGX0502..	DFTX202..					
—	DFSP175R4WD32M	—	—	17,50	18,50	99,0	70,0	0,5	SPGX0603..	DFT0303..					
—	DFSP180R4WD32M	—	—	18,00	19,00	101,0	72,0	0,5	SPGX0603..	DFT0303..					
—	DFSP185R4WD32M	—	—	18,50	19,50	103,0	74,0	0,6	SPGX0603..	DFT0303..					
—	DFSP190R4WD32M	—	—	19,00	20,00	105,0	76,0	0,6	SPGX0603..	DFT0303..					
—	DFSP195R4WD32M	—	—	19,50	20,50	107,0	78,0	0,6	SPGX0603..	DFT0303..					
—	DFSP200R4WD32M	—	—	20,00	21,00	112,0	80,0	0,6	SPGX0603..	DFT0303..					
—	DFSP210R4WD32M	—	—	21,00	22,00	96,0	64,0	0,7	SPGX0603..	DFT0303..					
—	DFSP220R4WD32M	—	—	22,00	23,00	120,0	88,0	0,5	SPGX0703..	DFT05T3..					
—	DFSP230R4WD32M	—	—	23,00	24,00	124,0	92,0	0,6	SPGX0703..	DFT05T3..					
—	DFSP240R4WD32M	—	—	24,00	25,00	128,0	96,0	0,6	SPGX0703..	DFT05T3..					
—	DFSP250R4WD32M	—	—	25,00	26,00	133,0	100,0	0,7	SPGX0703..	DFT05T3..					
—	DFSP260R4WD32M	—	—	26,00	27,00	138,0	104,0	0,7	SPPX09T3..	DFT05T3..					
—	DFSP265R4WD32M	—	—	26,50	27,50	140,0	106,0	0,7	SPPX09T3..	DFT05T3..					
—	DFSP270R4WD32M	—	—	27,00	28,00	143,0	108,0	0,8	SPPX09T3..	DFT05T3..					
—	DFSP280R4WD32M	—	—	28,00	29,00	147,0	112,0	0,8	SPPX09T3..	DFT05T3..					
—	DFSP290R4WD32M	—	—	29,00	30,00	152,0	116,0	0,9	SPPX09T3..	DFT05T3..					
—	DFSP300R4WD32M	—	—	30,00	31,00	157,0	120,0	0,9	SPPX09T3..	DFT05T3..					
—	DFSP310R4WD32M	—	—	31,00	32,00	162,0	124,0	0,9	SPPX09T3..	DFT05T3..					
—	DFSP320R4WD32M	—	—	32,00	33,00	167,0	128,0	1,0	SPPX09T3..	DFT05T3..					
—	DFSP330R4WD32M	—	—	33,00	34,00	171,0	132,0	0,9	SPPX1204..	DFT06T3..					
—	DFSP340R4WD32M	—	—	34,00	35,00	176,0	136,0	0,9	SPPX1204..	DFT06T3..					
—	DFSP350R4WD32M	—	—	35,00	36,00	181,0	140,0	1,0	SPPX1204..	DFT06T3..					
—	DFSP360R4WD32M	—	—	36,00	37,00	186,0	144,0	1,0	SPPX1204..	DFT06T3..					
—	DFSP370R4WD32M	—	—	37,00	38,00	191,0	148,0	1,1	SPPX1204..	DFT06T3..					
—	DFSP375R4WD32M	—	—	37,50	38,50	193,0	150,0	1,1	SPPX1204..	DFT06T3..					
—	DFSP380R4WD32M	—	—	38,00	39,00	195,0	152,0	1,1	SPPX1204..	DFT06T3..					
—	DFSP390R4WD32M	—	—	39,00	40,00	200,0	156,0	1,2	SPPX1204..	DFT06T3..					
—	DFSP400R4WD32M	—	—	40,00	41,00	205,0	160,0	1,2	SPPX1204..	DFT06T3..					
—	DFSP410R4WD32M	—	—	41,00	42,00	210,0	164,0	1,2	SPPX1204..	DFT0704..					

(continued)

(WD Shank • 4 x D • Metric — continued)

D				D1	D1 max	L1	L4 max	L5	gage insert outside	gage insert inside
20	32	40	50							
—	DFSP420R4WD32M	—	—	42,00	43,00	215,0	168,0	1,3	SPPX1204..	DFT0704..
—	DFSP430R4WD32M	—	—	43,00	44,00	219,0	172,0	1,3	SPPX1204..	DFT0704..
—	DFSP440R4WD32M	—	—	44,00	45,00	223,0	176,0	1,4	SPPX15T5..	DFT0704..
—	—	DFSP450R4WD40M	—	45,00	46,00	227,0	180,0	1,4	SPPX15T5..	DFT0704..
—	—	DFSP460R4WD40M	—	46,00	47,00	232,0	184,0	1,5	SPPX15T5..	DFT0704..
—	—	DFSP470R4WD40M	—	47,00	48,00	236,0	188,0	1,5	SPPX15T5..	DFT0704..
—	—	DFSP480R4WD40M	—	48,00	49,00	240,0	192,0	1,5	SPPX15T5..	DFT0704..
—	—	DFSP490R4WD40M	—	49,00	50,00	244,0	196,0	1,4	SPPX15T5..	DFT0905..
—	—	DFSP500R4WD40M	—	50,00	51,00	248,0	200,0	1,5	SPPX15T5..	DFT0905..
—	—	DFSP510R4WD40M	—	51,00	52,00	252,0	204,0	1,6	SPPX15T5..	DFT0905..
—	—	DFSP520R4WD40M	—	52,00	53,00	256,0	208,0	1,6	SPPX15T5..	DFT0905..
—	—	DFSP530R4WD40M	—	53,00	54,00	260,0	212,0	1,7	SPPX15T5..	DFT0905..
—	—	DFSP540R4WD40M	—	54,00	55,00	264,0	216,0	1,7	SPPX15T5..	DFT0905..
—	—	—	DFSP550R4WD50M	55,00	56,00	268,0	220,0	1,8	SPPX15T5..	DFT0905..

NOTE for D1 max: Diameter can be adjusted. It is highly recommended to not adjust the diameter more than +1mm.

NOTE: *Made-to-order standard item. Standard pricing, manufacturing lead time, and minimum order quantity applies.

Spare Parts



diameter range	gage insert inside	inboard insert screw	tightening torque Nm	gage insert outside	outboard insert screw	tightening torque Nm	Torx driver	Torx size
—	DFTX202..	—	—	SPGX0502..	—	—	—	T6
17.50–21.00	DFT0303..	MS1152	0,9	SPGX0603..	MS1152	0,9	170.023	T7
22.00–25.00	DFT05T3..	193.491	2,1	SPGX0703..	192.432	1,3	170.028	T8
26.00–32.00	DFT05T3..	191.924	2,1	SPPX09T3..	191.924	2,1	170.024	T9
33.00–40.00	DFT06T3..	191.916	4	SPPX1204..	191.916	4	170.025	T15
41.00–43.00	DFT0704..	192.433	6	SPPX1204..	191.698	3	170.025	T15
44.00–48.00	DFT0704..	191.698	6	SPPX15T5..	191.698	3	170.025	T15
49.00–55.00	DFT0905..	192.433	6	SPPX15T5..	192.433	6	170.025	T15

NOTE: To ensure proper clamping, two different screws for DFT™ inserts with different threads for diameter ranges 22–25mm and 41–48mm are necessary. Both screws have the same Torx size.

WARNING

During through-hole operations, a slug or disc is produced as the tool breaks through the workpiece. When the drill is stationary and the workpiece is rotating, this slug may be hurled from the chuck by centrifugal force. Provide adequate shielding to protect bystanders.

D	LS	CS
32	58	R 1/4 BSP
40	68	R 1/4 BSP
50	68	R 1/4 BSP

Indexable Drills

Drill Fix™ DFSP™ Bodies



- DFSP combines the economical squared outboard insert with the superior centring capabilities of the trigon inboard insert.
- Drill shipped with insert screws and Torx wrench.
- Order inserts for DFSP separately.
See pages J89–J90 for inserts.

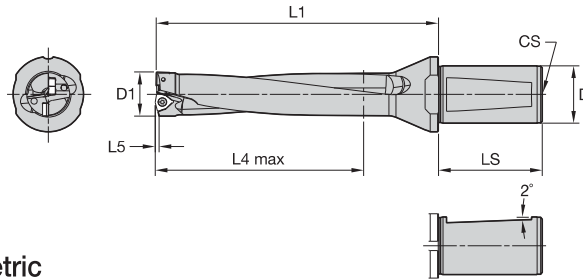
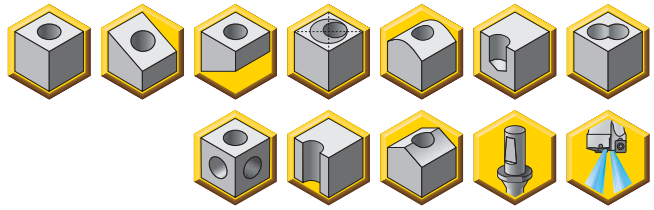

■ WD Shank • 5 x D • Metric

	D						gage insert outside	gage insert inside	
	32	40	50	D1	L1	L4 max			L5
DFSP200R5WD32M	—	—	—	20,00	132,0	100,0	0,6	SPGX0603..	DFT0303..
DFSP210R5WD32M	—	—	—	21,00	137,0	105,0	0,7	SPGX0603..	DFT0303..
DFSP220R5WD32M	—	—	—	22,00	142,0	110,0	0,5	SPGX0703..	DFT05T3..
DFSP230R5WD32M	—	—	—	23,00	147,0	115,0	0,6	SPGX0703..	DFT05T3..
DFSP240R5WD32M	—	—	—	24,00	152,0	120,0	0,6	SPGX0703..	DFT05T3..
DFSP250R5WD32M	—	—	—	25,00	158,0	125,0	0,7	SPGX0703..	DFT05T3..
DFSP260R5WD32M	—	—	—	26,00	164,0	130,0	0,7	SPPX09T3..	DFT05T3..
DFSP265R5WD32M	—	—	—	26,50	166,5	132,5	0,7	SPPX09T3..	DFT05T3..
DFSP270R5WD32M	—	—	—	27,00	170,0	135,0	0,8	SPPX09T3..	DFT05T3..
DFSP280R5WD32M	—	—	—	28,00	175,0	140,0	0,8	SPPX09T3..	DFT05T3..
DFSP290R5WD32M	—	—	—	29,00	181,0	145,0	0,9	SPPX09T3..	DFT05T3..
DFSP300R5WD32M	—	—	—	30,00	187,0	150,0	0,9	SPPX09T3..	DFT05T3..
DFSP310R5WD32M	—	—	—	31,00	193,0	155,0	0,9	SPPX09T3..	DFT05T3..
DFSP320R5WD32M	—	—	—	32,00	199,0	160,0	1,0	SPPX09T3..	DFT05T3..
DFSP330R5WD32M	—	—	—	33,00	204,0	165,0	0,9	SPPX1204..	DFT06T3..
DFSP340R5WD32M	—	—	—	34,00	210,0	170,0	0,9	SPPX1204..	DFT06T3..
DFSP350R5WD32M	—	—	—	35,00	216,0	175,0	1,0	SPPX1204..	DFT06T3..
DFSP360R5WD32M	—	—	—	36,00	222,0	180,0	1,0	SPPX1204..	DFT06T3..
DFSP370R5WD32M	—	—	—	37,00	228,0	185,0	1,1	SPPX1204..	DFT06T3..
DFSP375R5WD32M	—	—	—	37,50	230,5	187,5	1,1	SPPX1204..	DFT06T3..
DFSP380R5WD32M	—	—	—	38,00	233,0	190,0	1,1	SPPX1204..	DFT06T3..
DFSP390R5WD32M	—	—	—	39,00	239,0	195,0	1,2	SPPX1204..	DFT06T3..
DFSP400R5WD32M	—	—	—	40,00	245,0	200,0	1,2	SPPX1204..	DFT06T3..
DFSP410R5WD32M	—	—	—	41,00	251,0	205,0	1,2	SPPX1204..	DFT0704..
DFSP420R5WD32M	—	—	—	42,00	257,0	210,0	1,3	SPPX1204..	DFT0704..
DFSP430R5WD32M	—	—	—	43,00	262,0	215,0	1,3	SPPX1204..	DFT0704..
DFSP440R5WD32M	—	—	—	44,00	267,0	220,0	1,4	SPPX15T5..	DFT0704..
—	DFSP450R5WD40M	—	—	45,00	272,0	225,0	1,4	SPPX15T5..	DFT0704..
—	DFSP460R5WD40M	—	—	46,00	278,0	230,0	1,5	SPPX15T5..	DFT0704..
—	DFSP470R5WD40M	—	—	47,00	283,0	235,0	1,5	SPPX15T5..	DFT0704..
—	DFSP480R5WD40M	—	—	48,00	288,0	240,0	1,5	SPPX15T5..	DFT0704..
—	DFSP490R5WD40M	—	—	49,00	293,0	245,0	1,4	SPPX15T5..	DFT0905..
—	DFSP500R5WD40M	—	—	50,00	298,0	250,0	1,5	SPPX15T5..	DFT0905..
—	DFSP510R5WD40M *	—	—	51,00	303,0	255,0	1,6	SPPX15T5..	DFT0905..
—	DFSP520R5WD40M	—	—	52,00	308,0	260,0	1,6	SPPX15T5..	DFT0905..
—	DFSP530R5WD40M	—	—	53,00	313,0	265,0	1,7	SPPX15T5..	DFT0905..
—	DFSP540R5WD40M	—	—	54,00	318,0	270,0	1,7	SPPX15T5..	DFT0905..
—	—	DFSP550R5WD50M	—	55,00	323,0	275,0	1,8	SPPX15T5..	DFT0905..

NOTE: *Made-to-order standard item. Standard pricing, manufacturing lead time, and minimum order quantity applies.

(continued)

(WD Shank • 5 x D • Metric — continued)

Spare Parts



diameter range	gage insert inside	inboard insert screw	tightening torque Nm	gage insert outside	outboard insert screw	tightening torque Nm	Torx driver	Torx size
17.50–21.00	DFT0303..	MS1152	0,9	SPGX0603..	MS1152	0,9	170.023	T7
22.00–25.00	DFT05T3..	193.491	2,1	SPGX0703..	192.432	1,3	170.028	T8
26.00–32.00	DFT05T3..	191.924	2,1	SPPX09T3..	191.924	2,1	170.024	T9
33.00–40.00	DFT06T3..	191.916	4	SPPX1204..	191.916	4	170.025	T15
41.00–43.00	DFT0704..	192.433	6	SPPX1204..	191.698	3	170.025	T15
44.00–48.00	DFT0704..	191.698	6	SPPX15T5..	192.433	3	170.025	T15
49.00–55.00	DFT0905..	192.433	6	SPPX15T5..	192.433	6	170.025	T15

NOTE: To ensure proper clamping, two different screws for DFT™ inserts with different threads for diameter ranges 22–25mm and 41–48mm are necessary. Both screws have the same Torx size.



WARNING

During through-hole operations, a slug or disc is produced as the tool breaks through the workpiece. When the drill is stationary and the workpiece is rotating, this slug may be hurled from the chuck by centrifugal force. Provide adequate shielding to protect bystanders.

D	LS	CS
32	58	R 1/4 BSP
40	68	R 1/4 BSP
50	68	R 1/4 BSP

- DFSP combines the economical squared outboard insert with the superior centring capabilities of the trigon inboard insert.
- Drill shipped with insert screws, side pipe plug, and Torx wrench.
- Order inserts for DFSP separately.
See pages J89–J90 for inserts.

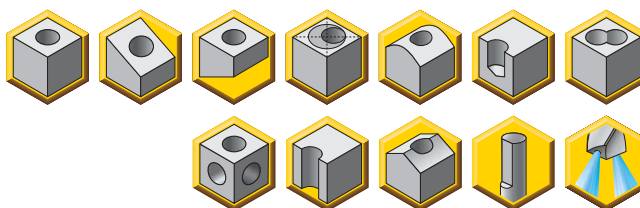

Indexable Drills

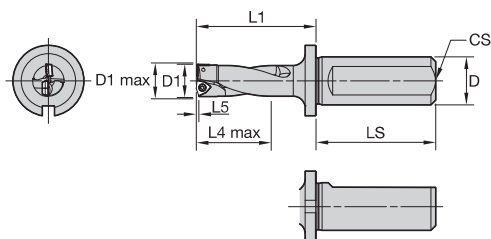

■ Weldon® Shank • DIN 1835-1 Form B • 2 x D • Metric

		D											
		20	25	32	40	D1	D1 max	L1	L4 max	L5	LS	gage insert outside	gage insert inside
DFSP140R2WB20M	—	—	—	—	—	14,00	15,00	50,0	28,0	0,3	50	SPGX0502..	DFTX202..
DFSP145R2WB20M	—	—	—	—	—	14,50	15,50	53,0	29,0	0,4	50	SPGX0502..	DFTX202..
DFSP150R2WB20M	—	—	—	—	—	15,00	16,00	54,0	30,0	0,4	50	SPGX0502..	DFTX202..
DFSP155R2WB20M	—	—	—	—	—	15,50	16,50	55,0	31,0	0,4	50	SPGX0502..	DFTX202..
DFSP160R2WB20M	—	—	—	—	—	16,00	17,00	56,0	32,0	0,4	50	SPGX0502..	DFTX202..
DFSP165R2WB20M	—	—	—	—	—	16,50	17,50	62,0	33,0	0,5	50	SPGX0502..	DFTX202..
DFSP170R2WB20M	—	—	—	—	—	17,00	18,00	63,0	34,0	0,5	50	SPGX0502..	DFTX202..
—	DFSP175R2WB25M	—	—	—	—	17,50	18,50	64,0	35,0	0,5	56	SPGX0603..	DFT0303..
—	DFSP180R2WB25M	—	—	—	—	18,00	19,00	65,0	36,0	0,5	56	SPGX0603..	DFT0303..
—	DFSP185R2WB25M	—	—	—	—	18,50	19,50	66,0	37,0	0,6	56	SPGX0603..	DFT0303..
—	DFSP190R2WB25M	—	—	—	—	19,00	20,00	67,0	38,0	0,6	56	SPGX0603..	DFT0303..
—	DFSP195R2WB25M	—	—	—	—	19,50	20,50	68,0	39,0	0,6	56	SPGX0603..	DFT0303..
—	DFSP200R2WB25M	—	—	—	—	20,00	21,00	72,0	40,0	0,6	56	SPGX0603..	DFT0303..
—	DFSP205R2WB25M	—	—	—	—	20,50	21,50	73,0	41,0	0,7	56	SPGX0603..	DFT0303..
—	DFSP209R2WB25M	—	—	—	—	20,90	21,90	73,8	41,8	0,7	56	SPGX0603..	DFT0303..
—	DFSP210R2WB25M	—	—	—	—	21,00	22,00	74,0	42,0	0,7	56	SPGX0603..	DFT0303..
—	DFSP215R2WB25M	—	—	—	—	21,50	22,50	75,0	43,0	0,7	56	SPGX0603..	DFT0303..
—	DFSP220R2WB25M	—	—	—	—	22,00	23,00	76,0	44,0	0,5	56	SPGX0703..	DFT05T3..
—	DFSP225R2WB25M	—	—	—	—	22,50	23,50	77,0	45,0	0,5	56	SPGX0703..	DFT05T3..
—	DFSP230R2WB25M	—	—	—	—	23,00	24,00	78,0	46,0	0,6	56	SPGX0703..	DFT05T3..
—	DFSP235R2WB25M	—	—	—	—	23,50	24,50	79,0	47,0	0,6	56	SPGX0703..	DFT05T3..
—	DFSP239R2WB25M	—	—	—	—	23,90	24,90	79,8	47,8	0,6	56	SPGX0703..	DFT05T3..
—	DFSP240R2WB25M	—	—	—	—	24,00	25,00	80,0	48,0	0,6	56	SPGX0703..	DFT05T3..
—	DFSP245R2WB25M	—	—	—	—	24,50	25,50	81,0	49,0	0,7	56	SPGX0703..	DFT05T3..
—	DFSP250R2WB25M	—	—	—	—	25,00	26,00	83,0	50,0	0,7	56	SPGX0703..	DFT05T3..
—	DFSP255R2WB25M	—	—	—	—	25,50	26,50	84,0	51,0	0,7	56	SPGX0703..	DFT05T3..
—	—	DFSP260R2WB32M	—	—	—	26,00	27,00	86,0	52,0	0,7	60	SPPX09T3..	DFT05T3..
—	—	DFSP264R2WB32M	—	—	—	26,40	27,40	86,8	52,8	0,7	60	SPPX09T3..	DFT05T3..
—	—	DFSP265R2WB32M	—	—	—	26,50	27,50	87,0	53,0	0,7	60	SPPX09T3..	DFT05T3..
—	—	DFSP270R2WB32M	—	—	—	27,00	28,00	89,0	54,0	0,8	60	SPPX09T3..	DFT05T3..
—	—	DFSP280R2WB32M	—	—	—	28,00	29,00	91,0	56,0	0,8	60	SPPX09T3..	DFT05T3..
—	—	DFSP290R2WB32M	—	—	—	29,00	30,00	94,0	58,0	0,9	60	SPPX09T3..	DFT05T3..
—	—	DFSP294R2WB32M	—	—	—	29,40	30,40	94,8	58,8	0,9	60	SPPX09T3..	DFT05T3..
—	—	DFSP300R2WB32M	—	—	—	30,00	31,00	97,0	60,0	0,9	60	SPPX09T3..	DFT05T3..
—	—	—	DFSP310R2WB40M	—	—	31,00	32,00	100,0	62,0	0,9	70	SPPX09T3..	DFT05T3..
—	—	—	DFSP320R2WB40M	—	—	32,00	33,00	103,0	64,0	1,0	70	SPPX09T3..	DFT05T3..

(continued)

(Weldon® Shank • DIN 1835-1 Form B • 2 x D • Metric — continued)

		D									
20	25	32	40	D1	D1 max	L1	L4 max	L5	LS	gage insert outside	gage insert inside
—	—	—	DFSP330R2WB40M	33,00	34,00	105,0	66,0	0,9	70	SPPX1204..	DFT06T3..
—	—	—	DFSP340R2WB40M	34,00	35,00	108,0	68,0	0,9	70	SPPX1204..	DFT06T3..
—	—	—	DFSP350R2WB40M	35,00	36,00	111,0	70,0	1,0	70	SPPX1204..	DFT06T3..
—	—	—	DFSP360R2WB40M	36,00	37,00	114,0	72,0	1,0	70	SPPX1204..	DFT06T3..
—	—	—	DFSP370R2WB40M	37,00	38,00	117,0	74,0	1,1	70	SPPX1204..	DFT06T3..
—	—	—	DFSP380R2WB40M	38,00	39,00	119,0	76,0	1,1	70	SPPX1204..	DFT06T3..
—	—	—	DFSP390R2WB40M	39,00	40,00	122,0	78,0	1,2	70	SPPX1204..	DFT06T3..
—	—	—	DFSP400R2WB40M	40,00	41,00	125,0	80,0	1,2	70	SPPX1204..	DFT06T3..

NOTE for D1 max: Diameter can be adjusted. It is highly recommended to not adjust the diameter more than +1mm.

Spare Parts



diameter range	gage insert inside	inboard insert screw	tightening torque Nm	gage insert outside	outboard insert screw	tightening torque Nm	Torx driver	Torx size
14.00–17.00	DFTX202..	1175225	0,66	SPGX0502..	1175225	0,66	5694202	T6
17.50–21.50	DFT0303..	1021337	0,90	SPGX0603..	1021337	0,90	1138413	T7
22.00–25.50	DFT05T3..	3124549	2,10	SPGX0703..	1134385	1,30	1138465	T8
26.00–32.00	DFT05T3..	1105612	2,10	SPPX09T3..	1105612	2,10	1138430	T9
33.00–40.00	DFT06T3..	1132523	4,00	SPPX1204..	1132523	4,00	1138438	T15

NOTE: To ensure proper clamping, two different screws for DFT™ inserts with different threads for diameter ranges 22–25mm and 41–48mm are necessary. Both screws have the same Torx size.

WARNING

During through-hole operations, a slug or disc is produced as the tool breaks through the workpiece. When the drill is stationary and the workpiece is rotating, this slug may be hurled from the chuck by centrifugal force. Provide adequate shielding to protect bystanders.

D	LS	CS
20	50	R 1/4 BSP
25	56	R 1/4 BSP
32	60	R 1/4 BSP
40	70	R 1/4 BSP

- DFSP combines the economical squared outboard insert with the superior centring capabilities of the trigon inboard insert.
- Drill shipped with insert screws, side pipe plug, and Torx wrench.
- Order inserts for DFSP separately.
See pages J89–J90 for inserts.

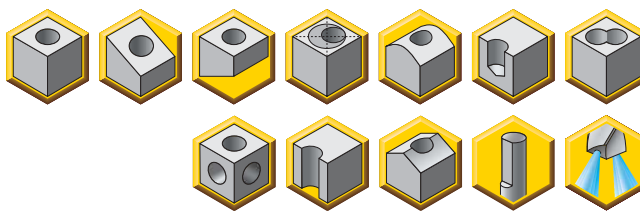

Indexable Drills

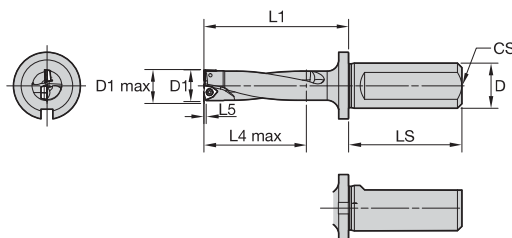

■ **Weldon® Shank • DIN 1835-1 Form B • 3 x D • Metric**

		D											
		20	25	32	40	D1	D1 max	L1	L4 max	L5	LS	gage insert outside	gage insert inside
DFSP140R3WB20M	—	—	—	—	—	14,00	15,00	64,0	42,0	0,3	50	SPGX0502..	DFTX202..
DFSP145R3WB20M	—	—	—	—	—	14,50	15,50	67,5	43,5	0,4	50	SPGX0502..	DFTX202..
DFSP150R3WB20M	—	—	—	—	—	15,00	16,00	69,0	45,0	0,4	50	SPGX0502..	DFTX202..
DFSP155R3WB20M	—	—	—	—	—	15,50	16,50	70,5	46,5	0,4	50	SPGX0502..	DFTX202..
DFSP160R3WB20M	—	—	—	—	—	16,00	17,00	72,0	48,0	0,4	50	SPGX0502..	DFTX202..
DFSP165R3WB20M	—	—	—	—	—	16,50	17,50	78,5	49,5	0,5	50	SPGX0502..	DFTX202..
DFSP170R3WB20M	—	—	—	—	—	17,00	18,00	80,0	51,0	0,5	50	SPGX0502..	DFTX202..
—	DFSP175R3WB25M	—	—	—	—	17,50	18,50	81,5	52,5	0,5	56	SPGX0603..	DFT0303..
—	DFSP180R3WB25M	—	—	—	—	18,00	19,00	83,0	54,0	0,5	56	SPGX0603..	DFT0303..
—	DFSP185R3WB25M	—	—	—	—	18,50	19,50	84,5	55,5	0,6	56	SPGX0603..	DFT0303..
—	DFSP190R3WB25M	—	—	—	—	19,00	20,00	86,0	57,0	0,6	56	SPGX0603..	DFT0303..
—	DFSP195R3WB25M	—	—	—	—	19,50	20,50	87,5	58,5	0,6	56	SPGX0603..	DFT0303..
—	DFSP200R3WB25M	—	—	—	—	20,00	21,00	92,0	60,0	0,6	56	SPGX0603..	DFT0303..
—	DFSP205R3WB25M	—	—	—	—	20,50	21,50	93,5	61,5	0,7	56	SPGX0603..	DFT0303..
—	DFSP209R3WB25M	—	—	—	—	20,90	21,90	94,7	62,7	0,7	56	SPGX0603..	DFT0303..
—	DFSP210R3WB25M	—	—	—	—	21,00	22,00	95,0	63,0	0,7	56	SPGX0603..	DFT0303..
—	DFSP215R3WB25M	—	—	—	—	21,50	22,50	96,5	64,5	0,7	56	SPGX0603..	DFT0303..
—	DFSP220R3WB25M	—	—	—	—	22,00	23,00	98,0	66,0	0,5	56	SPGX0703..	DFT05T3..
—	DFSP225R3WB25M	—	—	—	—	22,50	23,50	99,5	67,5	0,5	56	SPGX0703..	DFT05T3..
—	DFSP230R3WB25M	—	—	—	—	23,00	24,00	101,0	69,0	0,6	56	SPGX0703..	DFT05T3..
—	DFSP235R3WB25M	—	—	—	—	23,50	24,50	102,5	70,5	0,6	56	SPGX0703..	DFT05T3..
—	DFSP239R3WB25M	—	—	—	—	23,90	24,90	103,7	71,7	0,6	56	SPGX0703..	DFT05T3..
—	DFSP240R3WB25M	—	—	—	—	24,00	25,00	104,0	72,0	0,6	56	SPGX0703..	DFT05T3..
—	DFSP245R3WB25M	—	—	—	—	24,50	25,50	105,5	73,5	0,7	56	SPGX0703..	DFT05T3..
—	DFSP250R3WB25M	—	—	—	—	25,00	26,00	108,0	75,0	0,7	56	SPGX0703..	DFT05T3..
—	DFSP255R3WB25M	—	—	—	—	25,50	26,50	109,5	76,5	0,7	56	SPGX0703..	DFT05T3..
—	—	DFSP260R3WB32M	—	—	—	26,00	27,00	112,0	78,0	0,7	60	SPPX09T3..	DFT05T3..
—	—	DFSP264R3WB32M	—	—	—	26,40	27,40	113,2	79,2	0,7	60	SPPX09T3..	DFT05T3..
—	—	DFSP265R3WB32M	—	—	—	26,50	27,50	113,5	79,5	0,7	60	SPPX09T3..	DFT05T3..
—	—	DFSP270R3WB32M	—	—	—	27,00	28,00	116,0	81,0	0,8	60	SPPX09T3..	DFT05T3..
—	—	DFSP280R3WB32M	—	—	—	28,00	29,00	119,0	84,0	0,8	60	SPPX09T3..	DFT05T3..
—	—	DFSP290R3WB32M	—	—	—	29,00	30,00	123,0	87,0	0,9	60	SPPX09T3..	DFT05T3..

(continued)

(Weldon® Shank • DIN 1835-1 Form B • 3 x D • Metric — continued)

		D								gage insert	gage insert
20	25	32	40	D1	D1 max	L1	L4 max	L5	LS	outside	inside
—	—	DFSP294R3WB32M	—	29,40	30,40	124,2	88,2	0,9	60	SPPX09T3..	DFT05T3..
—	—	DFSP300R3WB32M	—	30,00	31,00	127,0	90,0	0,9	60	SPPX09T3..	DFT05T3..
—	—	—	DFSP310R3WB40M	31,00	32,00	131,0	93,0	0,9	70	SPPX09T3..	DFT05T3..
—	—	—	DFSP320R3WB40M	32,00	33,00	135,0	96,0	1,0	70	SPPX09T3..	DFT05T3..
—	—	—	DFSP330R3WB40M	33,00	34,00	138,0	99,0	0,9	70	SPPX1204..	DFT06T3..
—	—	—	DFSP340R3WB40M	34,00	35,00	142,0	102,0	0,9	70	SPPX1204..	DFT06T3..
—	—	—	DFSP350R3WB40M	35,00	36,00	146,0	105,0	1,0	70	SPPX1204..	DFT06T3..
—	—	—	DFSP360R3WB40M	36,00	37,00	150,0	108,0	1,0	70	SPPX1204..	DFT06T3..
—	—	—	DFSP370R3WB40M	37,00	38,00	154,0	111,0	1,1	70	SPPX1204..	DFT06T3..
—	—	—	DFSP380R3WB40M	38,00	39,00	157,0	114,0	1,1	70	SPPX1204..	DFT06T3..
—	—	—	DFSP390R3WB40M	39,00	40,00	161,0	117,0	1,2	70	SPPX1204..	DFT06T3..
—	—	—	DFSP400R3WB40M	40,00	41,00	165,0	120,0	1,2	70	SPPX1204..	DFT06T3..

NOTE for D1 max: Diameter can be adjusted. It is highly recommended to not adjust the diameter more than +1mm.

Spare Parts



diameter range	gage insert inside	inboard insert screw	tightening torque Nm	gage insert outside	outboard insert screw	tightening torque Nm	Torx driver	Torx size
14.00–17.00	DFTX202..	1175225	0,66	SPGX0502..	1175225	0,66	5694202	T6
17.50–21.50	DFT0303..	1021337	0,90	SPGX0603..	1021337	0,90	1138413	T7
22.00–25.50	DFT05T3..	3124549	2,10	SPGX0703..	1134385	1,30	1138465	T8
26.00–32.00	DFT05T3..	1105612	2,10	SPPX09T3..	1105612	2,10	1138430	T9
33.00–40.00	DFT06T3..	1132523	4,00	SPPX1204..	1132523	4,00	1138438	T15

NOTE: To ensure proper clamping, two different screws for DFT™ inserts with different threads for diameter ranges 22–25mm and 41–48mm are necessary. Both screws have the same Torx size.

WARNING

During through-hole operations, a slug or disc is produced as the tool breaks through the workpiece. When the drill is stationary and the workpiece is rotating, this slug may be hurled from the chuck by centrifugal force. Provide adequate shielding to protect bystanders.

D	LS	CS
20	50	R 1/4 BSP
25	56	R 1/4 BSP
32	60	R 1/4 BSP
40	70	R 1/4 BSP

- DFSP combines the economical squared outboard insert with the superior centring capabilities of the trigon inboard insert.
- Drill shipped with insert screws, side pipe plug, and Torx wrench.
- Order inserts for DFSP separately.
See pages J89–J90 for inserts.

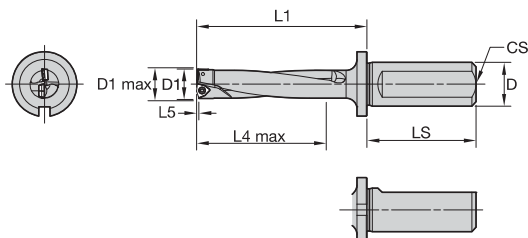
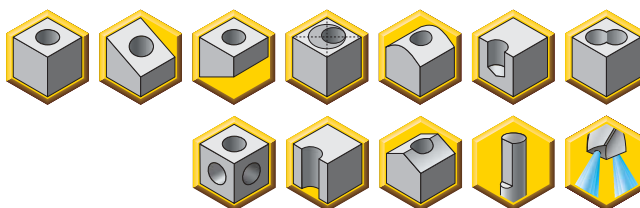

■ Weldon® Shank • DIN 1835-1 Form B • 4 x D • Metric

		D									gage insert	gage insert	
		20	25	32	40	D1	D1 max	L1	L4 max	L5	LS	outside	inside
DFSP140R4WB20M			—	—	—	14,00	15,00	78,0	56,0	0,3	50	SPGX0502..	DFTX202..
DFSP145R4WB20M			—	—	—	14,50	15,50	82,0	58,0	0,4	50	SPGX0502..	DFTX202..
DFSP150R4WB20M			—	—	—	15,00	16,00	84,0	60,0	0,4	50	SPGX0502..	DFTX202..
DFSP155R4WB20M			—	—	—	15,50	16,50	86,0	62,0	0,4	50	SPGX0502..	DFTX202..
DFSP160R4WB20M			—	—	—	16,00	17,00	88,0	64,0	0,4	50	SPGX0502..	DFTX202..
DFSP165R4WB20M			—	—	—	16,50	17,50	95,0	66,0	0,5	50	SPGX0502..	DFTX202..
DFSP170R4WB20M			—	—	—	17,00	18,00	97,0	68,0	0,5	50	SPGX0502..	DFTX202..
—	DFSP175R4WB25M		—	—	—	17,50	18,50	99,0	70,0	0,5	56	SPGX0603..	DFT0303..
—	DFSP180R4WB25M		—	—	—	18,00	19,00	101,0	72,0	0,5	56	SPGX0603..	DFT0303..
—	DFSP185R4WB25M		—	—	—	18,50	19,50	103,0	74,0	0,6	56	SPGX0603..	DFT0303..
—	DFSP190R4WB25M		—	—	—	19,00	20,00	105,0	76,0	0,6	56	SPGX0603..	DFT0303..
—	DFSP195R4WB25M		—	—	—	19,50	20,50	107,0	78,0	0,6	56	SPGX0603..	DFT0303..
—	DFSP200R4WB25M		—	—	—	20,00	21,00	112,0	80,0	0,6	56	SPGX0603..	DFT0303..
—	DFSP205R4WB25M		—	—	—	20,50	21,50	114,0	82,0	0,7	56	SPGX0603..	DFT0303..
—	DFSP209R4WB25M		—	—	—	20,90	21,90	115,6	83,6	0,7	56	SPGX0603..	DFT0303..
—	DFSP210R4WB25M		—	—	—	21,00	22,00	116,0	84,0	0,7	56	SPGX0603..	DFT0303..
—	DFSP215R4WB25M		—	—	—	21,50	22,50	118,0	86,0	0,7	56	SPGX0603..	DFT0303..
—	DFSP220R4WB25M		—	—	—	22,00	23,00	120,0	88,0	0,5	56	SPGX0703..	DFT05T3..
—	DFSP225R4WB25M		—	—	—	22,50	23,50	122,0	90,0	0,5	56	SPGX0703..	DFT05T3..
—	DFSP230R4WB25M		—	—	—	23,00	24,00	124,0	92,0	0,6	56	SPGX0703..	DFT05T3..
—	DFSP235R4WB25M		—	—	—	23,50	24,50	126,0	94,0	0,6	56	SPGX0703..	DFT05T3..
—	DFSP239R4WB25M		—	—	—	23,90	24,90	127,6	95,6	0,6	56	SPGX0703..	DFT05T3..
—	DFSP240R4WB25M		—	—	—	24,00	25,00	128,0	96,0	0,6	56	SPGX0703..	DFT05T3..
—	DFSP245R4WB25M		—	—	—	24,50	25,50	130,0	98,0	0,7	56	SPGX0703..	DFT05T3..
—	DFSP250R4WB25M		—	—	—	25,00	26,00	133,0	100,0	0,7	56	SPGX0703..	DFT05T3..
—	DFSP255R4WB25M		—	—	—	25,50	26,50	135,0	102,0	0,7	56	SPGX0703..	DFT05T3..
—	—		—	DFSP260R4WB32M	—	26,00	27,00	138,0	104,0	0,7	60	SPPX09T3..	DFT05T3..
—	—		—	DFSP264R4WB32M	—	26,40	27,40	139,6	105,6	0,7	60	SPPX09T3..	DFT05T3..
—	—		—	DFSP265R4WB32M	—	26,50	27,50	140,0	106,0	0,7	60	SPPX09T3..	DFT05T3..
—	—		—	DFSP270R4WB32M	—	27,00	28,00	143,0	108,0	0,8	60	SPPX09T3..	DFT05T3..
—	—		—	DFSP280R4WB32M	—	28,00	29,00	147,0	112,0	0,8	60	SPPX09T3..	DFT05T3..
—	—		—	DFSP290R4WB32M	—	29,00	30,00	152,0	116,0	0,9	60	SPPX09T3..	DFT05T3..

(continued)

(Weldon® Shank • DIN 1835-1 Form B • 4 x D • Metric — continued)

		D								gage insert	gage insert
20	25	32	40	D1	D1 max	L1	L4 max	L5	LS	outside	inside
—	—	DFSP294R4WB32M	—	29,40	30,40	153,6	117,6	0,9	60	SPPX09T3..	DFT05T3..
—	—	DFSP300R4WB32M	—	30,00	31,00	157,0	120,0	0,9	60	SPPX09T3..	DFT05T3..
—	—	—	DFSP310R4WB40M	31,00	32,00	162,0	124,0	0,9	70	SPPX09T3..	DFT05T3..
—	—	—	DFSP320R4WB40M	32,00	33,00	167,0	128,0	1,0	70	SPPX09T3..	DFT05T3..
—	—	—	DFSP330R4WB40M	33,00	34,00	171,0	132,0	0,9	70	SPPX1204..	DFT06T3..
—	—	—	DFSP340R4WB40M	34,00	35,00	176,0	136,0	0,9	70	SPPX1204..	DFT06T3..
—	—	—	DFSP350R4WB40M	35,00	36,00	181,0	140,0	1,0	70	SPPX1204..	DFT06T3..
—	—	—	DFSP360R4WB40M	36,00	37,00	186,0	144,0	1,0	70	SPPX1204..	DFT06T3..
—	—	—	DFSP370R4WB40M	37,00	38,00	191,0	148,0	1,1	70	SPPX1204..	DFT06T3..
—	—	—	DFSP380R4WB40M	38,00	39,00	195,0	152,0	1,1	70	SPPX1204..	DFT06T3..
—	—	—	DFSP390R4WB40M	39,00	40,00	200,0	156,0	1,2	70	SPPX1204..	DFT06T3..
—	—	—	DFSP400R4WB40M	40,00	41,00	205,0	160,0	1,2	70	SPPX1204..	DFT06T3..

NOTE for D1 max: Diameter can be adjusted. It is highly recommended to not adjust the diameter more than +1mm.

Spare Parts



diameter range	gage insert inside	inboard insert screw	tightening torque Nm	gage insert outside	outboard insert screw	tightening torque Nm	Torx driver	Torx size
14.00–17.00	DFTX202..	1175225	0,66	SPGX0502..	1175225	0,66	5694202	T6
17.50–21.50	DFT0303..	1021337	0,90	SPGX0603..	1021337	0,90	1138413	T7
22.00–25.50	DFT05T3..	3124549	2,10	SPGX0703..	1134385	1,30	1138465	T8
26.00–32.00	DFT05T3..	1105612	2,10	SPPX09T3..	1105612	2,10	1138430	T9
33.00–40.00	DFT06T3..	1132523	4,00	SPPX1204..	1132523	4,00	1138438	T15

NOTE: To ensure proper clamping, two different screws for DFT™ inserts with different threads for diameter ranges 22–25mm and 41–48mm are necessary. Both screws have the same Torx size.

WARNING

During through-hole operations, a slug or disc is produced as the tool breaks through the workpiece. When the drill is stationary and the workpiece is rotating, this slug may be hurled from the chuck by centrifugal force. Provide adequate shielding to protect bystanders.

D	LS	CS
20	50	R 1/4 BSP
25	56	R 1/4 BSP
32	60	R 1/4 BSP
40	70	R 1/4 BSP

- DFSP combines the economical squared outboard insert with the superior centring capabilities of the trigon inboard insert.
- Drill shipped with insert screws, side pipe plug, and Torx wrench.
- Order inserts for DFSP separately.
See pages J89–J90 for inserts.

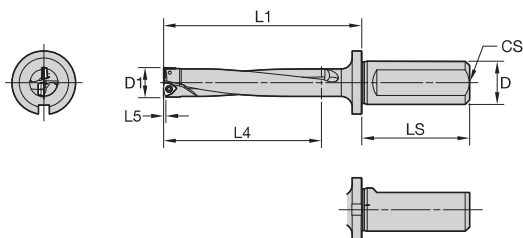
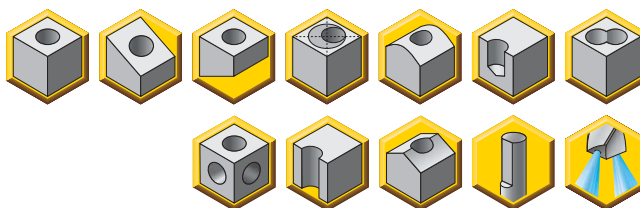

■ Weldon® Shank • DIN 1835-1 Form B • 5 x D • Metric

		D						gage insert outside	gage insert inside	
20	25	32	40	D1	L1	L4 max	L5	LS		
DFSP140R5WB20M	—	—	—	14,00	92,0	70,0	0,3	50	SPGX0502..	DFTX202..
DFSP145R5WB20M	—	—	—	14,50	96,5	72,5	0,4	50	SPGX0502..	DFTX202..
DFSP150R5WB20M	—	—	—	15,00	99,0	75,0	0,4	50	SPGX0502..	DFTX202..
DFSP155R5WB20M	—	—	—	15,50	101,5	77,5	0,4	50	SPGX0502..	DFTX202..
DFSP160R5WB20M	—	—	—	16,00	104,0	80,0	0,5	50	SPGX0502..	DFTX202..
DFSP165R5WB20M	—	—	—	16,50	111,5	82,5	0,5	50	SPGX0502..	DFTX202..
DFSP170R5WB20M	—	—	—	17,00	114,0	85,0	0,5	50	SPGX0502..	DFTX202..
—	DFSP175R5WB25M	—	—	17,50	116,5	87,5	0,5	56	SPGX0603..	DFT0303..
—	DFSP180R5WB25M	—	—	18,00	119,0	90,0	0,5	56	SPGX0603..	DFT0303..
—	DFSP185R5WB25M	—	—	18,50	121,5	92,5	0,6	56	SPGX0603..	DFT0303..
—	DFSP190R5WB25M	—	—	19,00	124,0	95,0	0,6	56	SPGX0603..	DFT0303..
—	DFSP195R5WB25M	—	—	19,50	126,5	97,5	0,6	56	SPGX0603..	DFT0303..
—	DFSP200R5WB25M	—	—	20,00	132,0	100,0	0,6	56	SPGX0603..	DFT0303..
—	DFSP205R5WB25M	—	—	20,50	134,5	102,5	0,7	56	SPGX0603..	DFT0303..
—	DFSP209R5WB25M	—	—	20,90	136,5	104,5	0,7	56	SPGX0603..	DFT0303..
—	DFSP210R5WB25M	—	—	21,00	137,0	105,0	0,7	56	SPGX0603..	DFT0303..
—	DFSP215R5WB25M	—	—	21,50	139,5	107,5	0,7	56	SPGX0603..	DFT0303..
—	DFSP220R5WB25M	—	—	22,00	142,0	110,0	0,5	56	SPGX0703..	DFT05T3..
—	DFSP225R5WB25M	—	—	22,50	144,5	112,5	0,5	56	SPGX0703..	DFT05T3..
—	DFSP230R5WB25M	—	—	23,00	147,0	115,0	0,6	56	SPGX0703..	DFT05T3..
—	DFSP235R5WB25M	—	—	23,50	149,5	117,5	0,6	56	SPGX0703..	DFT05T3..
—	DFSP239R5WB25M	—	—	23,90	151,5	119,5	0,6	56	SPGX0703..	DFT05T3..
—	DFSP240R5WB25M	—	—	24,00	152,0	120,0	0,6	56	SPGX0703..	DFT05T3..
—	DFSP245R5WB25M	—	—	24,50	154,5	122,5	0,7	56	SPGX0703..	DFT05T3..
—	DFSP250R5WB25M	—	—	25,00	158,0	125,0	0,7	56	SPGX0703..	DFT05T3..
—	DFSP255R5WB25M	—	—	25,50	160,5	127,5	0,7	56	SPGX0703..	DFT05T3..
—	—	DFSP260R5WB32M	—	26,00	163,0	130,0	0,7	60	SPPX09T3..	DFT05T3..
—	—	DFSP264R5WB32M	—	26,40	165,0	132,0	0,7	60	SPPX09T3..	DFT05T3..
—	—	DFSP265R5WB32M	—	26,50	165,5	132,5	0,7	60	SPPX09T3..	DFT05T3..
—	—	DFSP270R5WB32M	—	27,00	170,0	135,0	0,8	60	SPPX09T3..	DFT05T3..
—	—	DFSP280R5WB32M	—	28,00	175,0	140,0	0,8	60	SPPX09T3..	DFT05T3..
—	—	DFSP290R5WB32M	—	29,00	181,0	145,0	0,9	60	SPPX09T3..	DFT05T3..

(continued)

(Weldon® Shank • DIN 1835-1 Form B • 5 x D • Metric — continued)

D										gage insert	gage insert
20	25	32	40	D1	L1	L4 max	L5	LS		outside	inside
—	—	DFSP294R5WB32M	—	29,40	183,0	147,0	0,9	60		SPPX09T3..	DFT05T3..
—	—	DFSP300R5WB32M	—	30,00	187,0	150,0	0,9	60		SPPX09T3..	DFT05T3..
—	—	—	DFSP310R5WB40M	31,00	193,0	155,0	0,9	70		SPPX09T3..	DFT05T3..
—	—	—	DFSP320R5WB40M	32,00	199,0	160,0	1,0	70		SPPX09T3..	DFT05T3..
—	—	—	DFSP330R5WB40M	33,00	204,0	165,0	0,9	70		SPPX1204..	DFT06T3..
—	—	—	DFSP340R5WB40M	34,00	210,0	170,0	0,9	70		SPPX1204..	DFT06T3..
—	—	—	DFSP350R5WB40M	35,00	216,0	175,0	1,0	70		SPPX1204..	DFT06T3..
—	—	—	DFSP360R5WB40M	36,00	222,0	180,0	1,0	70		SPPX1204..	DFT06T3..
—	—	—	DFSP370R5WB40M	37,00	228,0	18,0	1,1	70		SPPX1204..	DFT06T3..
—	—	—	DFSP380R5WB40M	38,00	233,0	190,0	1,1	70		SPPX1204..	DFT06T3..
—	—	—	DFSP390R5WB40M	39,00	239,0	195,0	1,2	70		SPPX1204..	DFT06T3..
—	—	—	DFSP400R5WB40M	40,00	245,0	200,0	1,2	70		SPPX1204..	DFT06T3..

NOTE for D1 max: Diameter can be adjusted. It is highly recommended to not adjust the diameter more than +1mm.

Spare Parts



diameter range	gage insert inside	inboard insert screw	tightening torque Nm	gage insert outside	outboard insert screw	tightening torque Nm	Torx driver	Torx size
14.00–17.00	DFTX202..	1175225	0,66	SPGX0502..	1175225	0,66	5694202	T6
17.50–21.50	DFT0303..	1021337	0,90	SPGX0603..	1021337	0,90	1138413	T7
22.00–25.50	DFT05T3..	3124549	2,10	SPGX0703..	1134385	1,30	1138465	T8
26.00–32.00	DFT05T3..	1105612	2,10	SPPX09T3..	1105612	2,10	1138430	T9
33.00–40.00	DFT06T3..	1132523	4,00	SPPX1204..	1132523	4,00	1138438	T15

NOTE: To ensure proper clamping, two different screws for DFT™ inserts with different threads for diameter ranges 22–25mm and 41–48mm are necessary. Both screws have the same Torx size.

WARNING

During through-hole operations, a slug or disc is produced as the tool breaks through the workpiece. When the drill is stationary and the workpiece is rotating, this slug may be hurled from the chuck by centrifugal force. Provide adequate shielding to protect bystanders.

D	LS	CS
20	50	R 1/4 BSP
25	56	R 1/4 BSP
32	60	R 1/4 BSP
40	70	R 1/4 BSP

Drill Fix™ DFSP™ • Metric

Material Group		Condition	Pocket Seat	Geometry	Grade	Metric									
						Cutting Speed – vc			Recommended Feed Rate (fz) by Diameter						
						Range – m/min			Ø	SPGX05 DFTX2 14,00–18,00mm	SPGX06 DFT03 18,00–21,99mm	SPGX07 DFT05 22,00–25,99mm	SPGX09 DFT05 26,00–32,99mm	SPGX12 DFT06/..07 33,00–43,99mm	SPGX15 DFT07/..09 44,00–55,00mm
						min	Starting Value	max							
P	0	S	O LP	KCU40	310	325	360	mm/r	0,06–0,10	0,06–0,11	0,08–0,14	0,12–0,21	0,14–0,26	0,16–0,26	
			I DS	KCU40											
		U	O LP	KCU40	200	215	230	mm/r	0,05–0,07	0,06–0,08	0,07–0,10	0,07–0,12	0,09–0,15	0,11–0,21	
	I HP		KCU40												
	1	S	O FP	KCPK10	310	325	360	mm/r	0,06–0,11	0,08–0,14	0,10–0,18	0,14–0,25	0,16–0,30	0,18–0,30	
			I HP	KC7140											
		U	O FP	KCU25	200	215	230	mm/r	0,04–0,06	0,05–0,08	0,06–0,10	0,09–0,15	0,11–0,18	0,13–0,25	
	I HP		KC7140												
	2	S	O FP	KCPK10	310	325	360	mm/r	0,06–0,11	0,08–0,14	0,10–0,18	0,14–0,25	0,16–0,30	0,18–0,30	
			I HP	KC7140											
		U	O FP	KCU25	200	215	230	mm/r	0,04–0,06	0,05–0,08	0,06–0,10	0,09–0,15	0,11–0,18	0,13–0,25	
	I HP		KC7140												
	3	S	O FP	KCPK10	260	285	320	mm/r	0,06–0,11	0,08–0,14	0,10–0,18	0,14–0,25	0,16–0,30	0,18–0,30	
			I HP	KC7140											
		U	O HP	KCU25	180	195	220	mm/r	0,04–0,06	0,05–0,08	0,06–0,10	0,09–0,15	0,11–0,18	0,13–0,25	
	I HP		KC7140												
	4	S	O FP	KCPK10	220	250	300	mm/r	0,06–0,11	0,08–0,14	0,10–0,18	0,14–0,25	0,16–0,30	0,18–0,30	
			I HP	KC7140											
		U	O HP	KCU25	150	180	220	mm/r	0,04–0,06	0,05–0,08	0,06–0,10	0,09–0,15	0,11–0,18	0,13–0,25	
	I HP		KC7140												
	5	S	O HP	KCU25	180	200	220	mm/r	0,06–0,11	0,08–0,14	0,10–0,18	0,14–0,25	0,16–0,30	0,18–0,30	
			I HP	KC7140											
		U	O HP	KCU40	120	135	150	mm/r	0,04–0,06	0,05–0,08	0,06–0,10	0,09–0,15	0,11–0,18	0,13–0,25	
	I HP		KC7140												
6	S	O HP	KCU25	180	200	220	mm/r	0,06–0,11	0,08–0,14	0,10–0,18	0,14–0,25	0,16–0,30	0,18–0,30		
		I HP	KC7140												
	U	O HP	KCU40	120	135	150	mm/r	0,04–0,06	0,05–0,08	0,06–0,10	0,09–0,15	0,11–0,18	0,13–0,25		
I HP		KC7140													
M	1	S	O LP	KCU40	150	190	230	mm/r	0,05–0,08	0,06–0,10	0,07–0,12	0,10–0,16	0,12–0,21	0,14–0,24	
			I DS	KCU40											
		U	O LP	KCU40	100	130	160	mm/r	0,05–0,07	0,06–0,08	0,07–0,10	0,05–0,10	0,06–0,13	0,08–0,16	
	I MD		KC7140												
	2	S	O LP	KCU40	150	180	210	mm/r	0,05–0,08	0,06–0,10	0,07–0,12	0,10–0,16	0,12–0,21	0,14–0,24	
			I DS	KCU40											
		U	O MD	KCU40	100	130	160	mm/r	0,03–0,05	0,04–0,07	0,05–0,09	0,07–0,13	0,08–0,16	0,10–0,20	
	I MD		KC7140												
	3	S	O LP	KCU40	100	130	160	mm/r	0,05–0,07	0,06–0,08	0,07–0,10	0,05–0,10	0,06–0,13	0,08–0,16	
			I DS	KCU40											
		U	O HP	KCU40	80	110	140	mm/r	0,03–0,05	0,04–0,07	0,05–0,09	0,07–0,13	0,08–0,16	0,10–0,20	
	I MD		KC7140												

NOTE: Applying Drill Fix™ DFSP 5 x D requires high stability. It is highly recommended to be conservative in regard to speeds and feeds, and start with minimum values indicated.

Condition: S = Stable cutting conditions;
 U = Unstable cutting conditions;
 I = Interrupted cutting conditions

Pocket seat: I = Inboard insert;
 O = Outboard insert

■ Drill Fix™ DFSP™ • Metric

Material Group		Condition	Pocket Seat	Geometry	Grade	Metric									
						Cutting Speed – vc			Recommended Feed Rate (fz) by Diameter						
						min	Starting Value	max	Ø	SPGX05 DFTX2 14,00–18,00mm	SPGX06 DFT03 18,00–21,99mm	SPGX07 DFT05 22,00–25,99mm	SPGX09 DFT05 26,00–32,99mm	SPGX12 DFT06/.07 33,00–43,99mm	SPGX15 DFT07/.09 44,00–55,00mm
K	1	S	O	FP	KCPK10	200	240	300	mm/r	0,07–0,12	0,10–0,16	0,12–0,20	0,16–0,28	0,18–0,32	0,20–0,34
		I	HP	HP	KCU40										
		I	HP	HP	KCU25	120	155	200	mm/r	0,05–0,09	0,06–0,12	0,08–0,15	0,12–0,20	0,14–0,25	0,16–0,28
	2	S	O	FP	KCPK10	180	220	260	mm/r	0,07–0,12	0,10–0,16	0,12–0,20	0,16–0,28	0,18–0,32	0,20–0,34
		I	HP	HP	KCU40										
		I	HP	HP	KCU25	110	140	170	mm/r	0,05–0,09	0,06–0,12	0,08–0,15	0,12–0,20	0,14–0,25	0,16–0,28
	3	S	O	FP	KCPK10	180	220	260	mm/r	0,07–0,12	0,10–0,16	0,12–0,20	0,16–0,28	0,18–0,32	0,20–0,34
		I	HP	HP	KCU40										
		I	HP	HP	KCU25	110	140	170	mm/r	0,05–0,09	0,06–0,12	0,08–0,15	0,12–0,20	0,14–0,25	0,16–0,28
N	1	S	O	HP	KCPK10	350	500	650	mm/r	0,07–0,12	0,10–0,16	0,12–0,20	0,16–0,28	0,18–0,32	0,20–0,34
		I	HP	KMF											
		I	HP	KCU40	300	400	500	mm/r	0,05–0,09	0,06–0,12	0,08–0,15	0,12–0,20	0,14–0,25	0,16–0,28	
	2	S	O	HP	KCPK10	300	400	500	mm/r	0,07–0,12	0,10–0,16	0,12–0,20	0,16–0,28	0,18–0,32	0,20–0,34
		I	HP	KMF											
		I	HP	KCU40	250	350	450	mm/r	0,05–0,09	0,06–0,12	0,08–0,15	0,12–0,20	0,14–0,25	0,16–0,28	
	3	S	O	HP	KCPK10	300	400	500	mm/r	0,07–0,12	0,10–0,16	0,12–0,20	0,16–0,28	0,18–0,32	0,20–0,34
		I	HP	KMF											
		I	HP	KCU40	250	350	450	mm/r	0,05–0,09	0,06–0,12	0,08–0,15	0,12–0,20	0,14–0,25	0,16–0,28	
	4	S	O	HP	KCPK10	300	400	500	mm/r	0,07–0,12	0,10–0,16	0,12–0,20	0,16–0,28	0,18–0,32	0,20–0,34
		I	HP	KMF											
		I	HP	KCU40	250	350	450	mm/r	0,05–0,09	0,06–0,12	0,08–0,15	0,12–0,20	0,14–0,25	0,16–0,28	
	5	S	O	HP	KCPK10	300	400	500	mm/r	0,07–0,12	0,10–0,16	0,12–0,20	0,16–0,28	0,18–0,32	0,20–0,34
		I	HP	KMF											
		I	HP	KCU40	250	350	450	mm/r	0,05–0,09	0,06–0,12	0,08–0,15	0,12–0,20	0,14–0,25	0,16–0,28	
	6	S	O	HP	KCPK10	400	450	500	mm/r	0,07–0,12	0,10–0,16	0,12–0,20	0,16–0,28	0,18–0,32	0,20–0,34
		I	HP	KMF											
		I	HP	KCU40	250	350	450	mm/r	0,05–0,09	0,06–0,12	0,08–0,15	0,12–0,20	0,14–0,25	0,16–0,28	
7	S	O	HP	KCPK10	200	300	400	mm/r	0,04–0,06	0,05–0,08	0,06–0,10	0,09–0,15	0,11–0,18	0,13–0,25	
	I	HP	KMF												
	I	HP	KCU40	200	300	400	mm/r	0,04–0,06	0,05–0,08	0,06–0,10	0,09–0,15	0,11–0,18	0,13–0,25		

NOTE: Applying Drill Fix™ DFSP 5 x D requires high stability. It is highly recommended to be conservative in regard to speeds and feeds, and start with minimum values indicated.

Condition: S = Stable cutting conditions;
U = Unstable cutting conditions;
I = Interrupted cutting conditions

Pocket seat: I = Inboard insert;
O = Outboard insert



■ Drill Fix™ DFSP™ • Metric

Metric															
Material Group	Condition	Pocket Seat	Geometry	Grade	Cutting Speed – vc			Recommended Feed Rate (fz) by Diameter							
					Range – m/min			Ø	SPGX05	SPGX06	SPGX07	SPGX09	SPGX12	SPGX15	
					min	Starting Value	max		DFTX2	DFT03	DFT05	DFT05	DFT06/..07	DFT07/..09	
					14,00–18,00mm	18,00–21,99mm	22,00–25,99mm	26,00–32,99mm	33,00–43,99mm	44,00–55,00mm					
S	1	S	O HP	KCU40	60	70	75	mm/r	0,03–0,06	0,04–0,08	0,05–0,10	0,08–0,12	0,10–0,15	0,12–0,18	
			I MD	KC7140											
		U	O HP	KCU40	40	50	60	mm/r	0,02–0,03	0,02–0,04	0,03–0,05	0,04–0,06	0,05–0,08	0,06–0,10	
			I MD	KC7140											
			I	O HP	KCU40	25	30	40	mm/r	0,02–0,03	0,02–0,04	0,03–0,05	0,04–0,06	0,05–0,08	0,06–0,10
			I MD	KC7140											
	2	S	O HP	KCU40	50	60	70	mm/r	0,03–0,06	0,04–0,08	0,05–0,10	0,08–0,12	0,10–0,15	0,12–0,18	
			I MD	KC7140											
		U	O HP	KCU40	30	40	50	mm/r	0,02–0,03	0,02–0,04	0,03–0,05	0,04–0,06	0,05–0,08	0,06–0,10	
			I MD	KC7140											
			I	O HP	KCU40	25	30	40	mm/r	0,02–0,03	0,02–0,04	0,03–0,05	0,04–0,06	0,05–0,08	0,06–0,10
			I MD	KC7140											
3	S	O LP	KCU40	70	80	90	mm/r	0,03–0,06	0,04–0,08	0,05–0,10	0,08–0,12	0,10–0,15	0,12–0,18		
		I DS	KC7140												
	U	O LP	KCU40	50	60	70	mm/r	0,02–0,03	0,02–0,04	0,03–0,05	0,04–0,06	0,05–0,08	0,06–0,10		
		I DS	KC7140												
		I	O HP	KCU40	30	40	50	mm/r	0,02–0,03	0,02–0,04	0,03–0,05	0,04–0,06	0,05–0,08	0,06–0,10	
		I MD	KC7140												
4	S	O LP	KCU40	70	80	90	mm/r	0,03–0,06	0,04–0,08	0,05–0,10	0,08–0,12	0,10–0,15	0,12–0,18		
		I DS	KC7140												
	U	O LP	KCU40	50	60	70	mm/r	0,02–0,03	0,02–0,04	0,03–0,05	0,04–0,06	0,05–0,08	0,06–0,10		
		I DS	KC7140												
		I	O HP	KCU40	30	40	50	mm/r	0,02–0,03	0,02–0,04	0,03–0,05	0,04–0,06	0,05–0,08	0,06–0,10	
		I MD	KC7140												

NOTE: Applying Drill Fix™ DFSP 5 x D requires high stability. It is highly recommended to be conservative in regard to speeds and feeds, and start with minimum values indicated.

Condition: S = Stable cutting conditions;
 U = Unstable cutting conditions;
 I = Interrupted cutting conditions

Pocket seat: I = Inboard insert;
 O = Outboard insert



Kennametal on the Web

kennametal.com

FIND THE LATEST PRODUCT INFORMATION

Whether your operation is turning, milling, or holemaking, Kennametal brands are the high-performance tooling you need. We offer standard and custom solutions for a wide range of applications.

Find information about our most current campaigns and catalogues.

Register on Konnect for the full functionality of the Kennametal online ordering website.

CONTACT US

Our customers are important to us. We want to provide you the best customer service in the industry. If you have a comment or question, please send it to us. We strive to respond to all inquiries within 24 hours.

FIND A LOCAL AUTHORISED DISTRIBUTOR IN YOUR AREA

Kennametal offers world-class products and services globally. Our distributors know us, and more importantly, they know you. They know better than anyone in the industry how to put the global power of Kennametal to work for you — in your industry, in your region, and for your business.

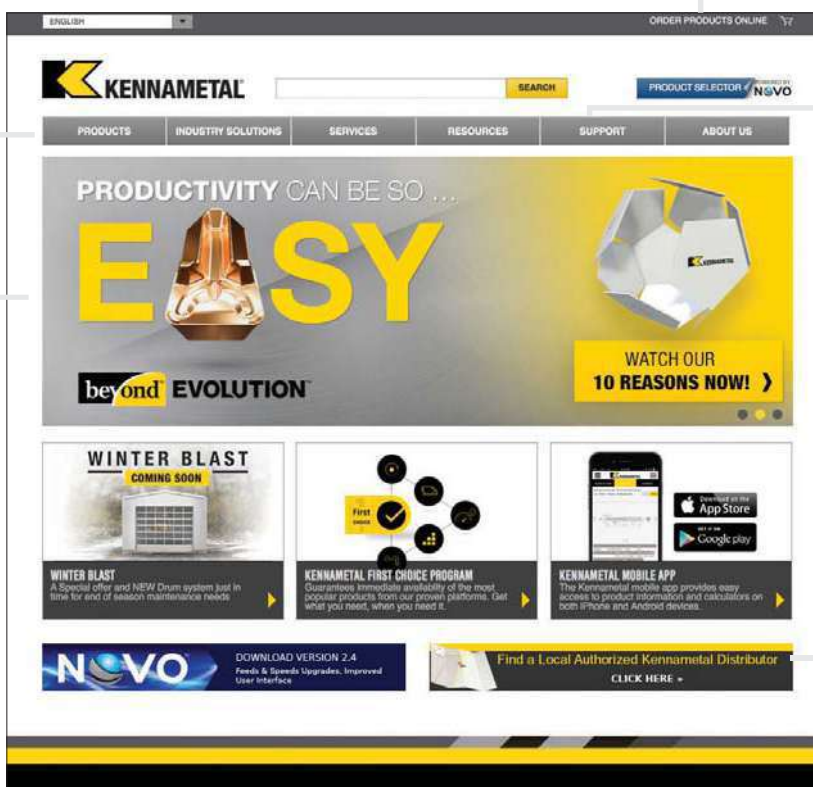

Drill Fix™ DFT™

Primary Application

The Drill Fix DFT system is available in diameter range 24–82mm (.625–3.250") as a versatile and reliable tool solution with a large portfolio of lengths, insert geometries, and grades.

Balanced cutting forces, improved chip flute, and coolant-channel design enable high metal removal rates and long tool body life. The trigon-shaped DFT inserts are used for both inboard and outboard inserts and offer the highest centring capabilities. Each insert has three cutting edges.

Features and Benefits

Productivity and Profitability

- Achieve high hole accuracy with trigon-shaped inboard inserts that offer the highest centring capabilities.
- Use X-offset on turning machines to adjust the drill diameter and eliminate the need for specials in many applications, and on machining centres to reach tolerance optimisation.
- Same insert size is used in each pocket, reducing inventory costs.

Versatility

- Diameter range covering 24–82mm (.625–3.250").
- 2.5 x D and 4 x D L/D ratios are standard.
- Various shanks available as standard: WD and SSF.
- Trigon-shaped inserts feature three cutting edges.
- Large variety of DFT insert grades and geometries available.
- Use DFT drills in straight holes, inclined entries and exits, interrupted cuts, and rough or welded entry surfaces.
- Eccentric chuck available as standard.

Versatile and reliable tool solution with a large portfolio of lengths, insert geometries, and grades.



Reliability

- Highest centring capabilities due to trigon-shaped insert.
- Same insert can be used as inboard or outboard insert — no risk of mixing up inner and outer inserts.
- Improved chip flute and coolant-channel design result in long tool body life and excellent chip evacuation.

Customisation

- Intermediate diameters available as semi-standards.
- Engineered solutions available.
- Multistep drills available upon request.
- Stacked material version.

- Drill shipped with insert screws and Torx wrench.
- See pages J85 and J87–J88 for inserts.

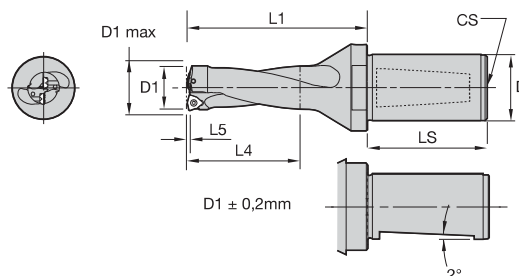
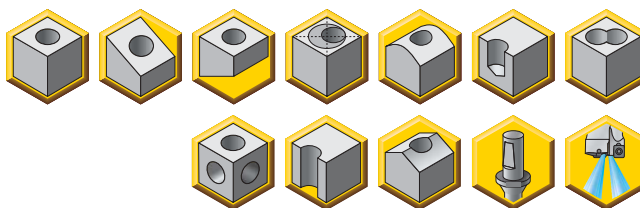

Indexable Drills

■ WN/WD Shank • 2,5 x D • Metric

D			D1	D1 max	L1	L4 max	L5	gage insert
32	40	50						
DFT250R2WD32M	DFT250R2WD40M	—	25,00	27,00	90,0	58,9	0,9	DFT05T3..
DFT260R2WD32M	DFT260R2WD40M	—	26,00	27,00	90,0	59,1	1,1	DFT05T3..
DFT270R2WD32M	DFT270R2WD40M	—	27,00	29,00	100,0	66,1	1,1	DFT05T3..
DFT280R2WD32M	DFT280R2WD40M	—	28,00	29,00	100,0	66,3	1,3	DFT05T3..
DFT290R2WD32M	DFT290R2WD40M	—	29,00	31,00	100,0	66,3	1,3	DFT05T3..
DFT300R2WD32M	DFT300R2WD40M	—	30,00	31,00	115,0	76,4	1,4	DFT05T3..
DFT310R2WD32M	DFT310R2WD40M	—	31,00	33,00	115,0	76,4	1,4	DFT05T3..
DFT320R2WD32M	DFT320R2WD40M	—	32,00	33,00	115,0	76,5	1,5	DFT05T3..
DFT330R2WD32M	DFT330R2WD40M	—	33,00	35,00	115,0	76,4	1,4	DFT06T3..
DFT340R2WD32M	DFT340R2WD40M	—	34,00	35,00	115,0	76,5	1,5	DFT06T3..
DFT350R2WD32M	DFT350R2WD40M	—	35,00	38,00	115,0	76,6	1,6	DFT06T3..
DFT360R2WD32M	DFT360R2WD40M	—	36,00	37,00	115,0	76,8	1,8	DFT06T3..
DFT370R2WD32M	DFT370R2WD40M	—	37,00	38,00	135,0	96,7	1,7	DFT06T3..
DFT380R2WD32M	DFT380R2WD40M	—	38,00	41,00	135,0	96,8	1,8	DFT06T3..
DFT390R2WD32M	DFT390R2WD40M	—	39,00	40,00	135,0	96,9	1,9	DFT06T3..
DFT400R2WD32M	DFT400R2WD40M	—	40,00	41,00	135,0	97,0	2,0	DFT06T3..
DFT410R2WD32M	DFT410R2WD40M	—	41,00	44,00	135,0	96,9	1,9	DFT0704..
DFT420R2WD32M	DFT420R2WD40M	—	42,00	43,00	135,0	96,9	2,0	DFT0704..
DFT430R2WD32M	DFT430R2WD40M	—	43,00	44,00	150,0	112,1	2,1	DFT0704..
DFT440R2WD32M	DFT440R2WD40M	—	44,00	47,00	150,0	112,1	2,1	DFT0704..
—	DFT450R2WD40M	DFT450R2WD50M	45,00	46,00	150,0	112,2	2,2	DFT0704..
—	DFT460R2WD40M	DFT460R2WD50M	46,00	47,00	150,0	112,0	2,3	DFT0704..
—	DFT470R2WD40M	DFT470R2WD50M *	47,00	50,00	150,0	111,5	2,4	DFT0704..
—	DFT480R2WD40M	DFT480R2WD50M	48,00	49,00	150,0	111,0	2,4	DFT0704..
—	DFT490R2WD40M	DFT490R2WD50M	49,00	50,00	165,0	117,2	2,2	DFT0905..
—	DFT500R2WD40M	DFT500R2WD50M	50,00	54,00	165,0	117,2	2,2	DFT0905..
—	DFT510R2WD40M	DFT510R2WD50M	51,00	52,00	165,0	117,4	2,5	DFT0905..
—	DFT520R2WD40M	DFT520R2WD50M	52,00	53,00	165,0	117,5	2,6	DFT0905..
—	DFT530R2WD40M	DFT530R2WD50M	53,00	54,00	165,0	117,6	2,6	DFT0905..
—	DFT540R2WD40M	DFT540R2WD50M	54,00	58,00	165,0	117,7	2,7	DFT0905..
—	—	DFT550R2WD50M	55,00	56,00	180,0	125,0	2,7	DFT0905..
—	—	DFT560R2WD50M	56,00	57,00	180,0	125,0	2,8	DFT0905..
—	—	DFT570R2WD50M	57,00	58,00	180,0	125,0	2,9	DFT0905..
—	—	DFT580R2WD50M	58,00	62,00	180,0	125,0	3,0	DFT0905..
—	—	DFT590R2WD50M	59,00	60,00	180,0	125,0	3,0	DFT0905..
—	—	DFT600R2WD50M	60,00	61,00	180,0	125,0	3,1	DFT0905..

(continued)



(WN/WD Shank • 2,5 x D • Metric — continued)

D			D1	D1 max	L1	L4 max	L5	gage insert
32	40	50						
—	—	DFT610R2WD50M	61,00	62,00	180,0	125,0	3,2	DFT0905..
—	—	DFT620R2WD50M	62,00	65,00	180,0	125,0	3,2	DFT0905..
—	—	DFT630R2WD50M	63,00	64,00	180,0	125,0	3,3	DFT0905..
—	—	DFT640R2WD50M	64,00	65,00	180,0	125,0	3,4	DFT0905..
—	—	DFT650R2WD50M	65,00	66,00	180,0	125,0	3,4	DFT0905..
—	—	DFT660R2WD50M	66,00	69,00	180,0	125,0	3,5	DFT0905..
—	—	DFT670R2WD50M	67,00	67,00	180,0	125,0	3,5	DFT0905..
—	—	DFT680R2WD50M	68,00	69,00	180,0	125,0	3,6	DFT0905..
—	—	DFT690R2WD50M	69,00	73,00	205,0	140,0	3,6	DFT1105..
—	—	DFT700R2WD50M	70,00	71,00	205,0	140,0	3,6	DFT1105..
—	—	DFT710R2WD50M	71,00	72,00	205,0	140,0	3,9	DFT1105..
—	—	DFT720R2WD50M	72,00	73,00	205,0	140,0	3,9	DFT1105..
—	—	DFT730R2WD50M	73,00	79,00	205,0	140,0	4,0	DFT1105..
—	—	DFT740R2WD50M	74,00	75,00	205,0	140,0	4,1	DFT1105..
—	—	DFT750R2WD50M	75,00	76,00	205,0	140,0	4,2	DFT1105..
—	—	DFT760R2WD50M	76,00	77,00	205,0	140,0	4,2	DFT1105..
—	—	DFT770R2WD50M	77,00	78,00	205,0	140,0	4,3	DFT1105..
—	—	DFT780R2WD50M	78,00	79,00	205,0	140,0	4,3	DFT1105..
—	—	DFT790R2WD50M	79,00	82,00	205,0	140,0	4,4	DFT1105..
—	—	DFT800R2WD50M	80,00	81,00	205,0	140,0	4,5	DFT1105..
—	—	DFT810R2WD50M *	81,00	82,00	205,0	140,0	4,5	DFT1105..
—	—	DFT820R2WD50M	82,00	83,00	205,0	140,0	4,5	DFT1105..

NOTE: *Made-to-order standard item. Standard pricing, manufacturing lead time, and minimum order quantity applies.

WARNING

During through-hole operations, a slug or disc is produced as the tool breaks through the workpiece. When the drill is stationary and the workpiece is rotating, this slug may be hurled from the chuck by centrifugal force. Provide adequate shielding to protect bystanders.

gage insert	 		Torx size
	insert screw	Torx wrench	
DFT05T3..	191.924	170.024	9
DFT06T3..	191.848	170.025	15
DFT0704..	191.698	170.025	15
DFT0905..	191.726	170.026	20
DFT1105..	191.375	170.026	20

D	LS	CS
32	58	R 1/4 BSP
40	68	R 1/4 BSP
50	68	R 1/4 BSP

- Drill shipped with insert screws and Torx wrench.
- See pages J85 and J87–J88 for inserts.

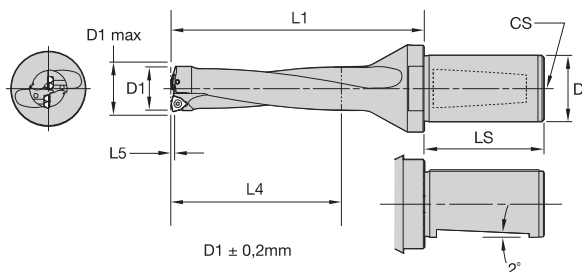
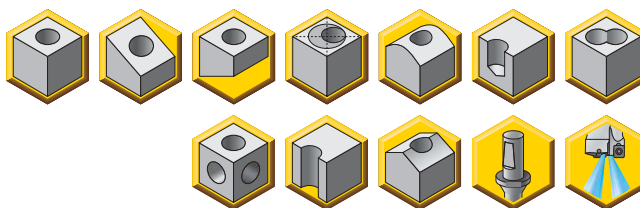

■ WN/WD Shank • 4 x D • Metric

D		D1	D1 max	L1	L4 max	L5	gage insert
32	40						
DFT250R4WD32M	DFT250R4WD40M	25,00	27,00	135,0	100,0	0,8	DFT05T3..
DFT260R4WD32M	DFT260R4WD40M	26,00	27,00	139,0	104,0	0,9	DFT05T3..
DFT270R4WD32M	DFT270R4WD40M	27,00	29,00	143,0	108,0	1,0	DFT05T3..
DFT280R4WD32M	DFT280R4WD40M	28,00	29,00	156,0	112,0	1,1	DFT05T3..
DFT290R4WD32M	DFT290R4WD40M	29,00	31,00	151,0	116,0	1,1	DFT05T3..
DFT300R4WD32M	DFT300R4WD40M	30,00	31,00	160,0	120,0	1,2	DFT05T3..
DFT310R4WD32M	DFT310R4WD40M	31,00	33,00	164,0	124,0	1,3	DFT05T3..
DFT320R4WD32M	DFT320R4WD40M	32,00	33,00	168,0	128,0	1,3	DFT05T3..
—	DFT330R4WD40M	33,00	35,00	177,0	132,0	1,1	DFT06T3..
—	DFT340R4WD40M	34,00	35,00	181,0	136,0	1,3	DFT06T3..
—	DFT350R4WD40M	35,00	38,00	185,0	140,0	1,3	DFT06T3..
—	DFT360R4WD40M	36,00	37,00	189,0	144,0	1,4	DFT06T3..
—	DFT370R4WD40M	37,00	38,00	198,0	148,0	1,5	DFT06T3..
—	DFT380R4WD40M	38,00	41,00	202,0	152,0	1,5	DFT06T3..
—	DFT390R4WD40M	39,00	40,00	206,0	156,0	1,6	DFT06T3..
—	DFT400R4WD40M	40,00	41,00	210,0	160,0	1,7	DFT06T3..
—	DFT410R4WD40M	41,00	44,00	214,0	164,0	1,6	DFT0704..
—	DFT420R4WD40M	42,00	43,00	223,0	168,0	1,7	DFT0704..
—	DFT430R4WD40M	43,00	44,00	227,0	172,0	1,7	DFT0704..
—	DFT440R4WD40M	44,00	47,00	231,0	176,0	1,8	DFT0704..
—	DFT450R4WD40M	45,00	46,00	240,0	180,0	1,9	DFT0704..
—	DFT460R4WD40M	46,00	47,00	244,0	184,0	1,9	DFT0704..
—	DFT470R4WD40M	47,00	50,00	248,0	188,0	2,0	DFT0704..
—	DFT480R4WD40M	48,00	49,00	252,0	192,0	2,0	DFT0704..

WARNING

During through-hole operations, a slug or disc is produced as the tool breaks through the workpiece. When the drill is stationary and the workpiece is rotating, this slug may be hurled from the chuck by centrifugal force. Provide adequate shielding to protect bystanders.



gage insert	insert screw	Torx wrench	Torx size
DFT05T3..	191.924	170.024	9
DFT06T3..	191.848	170.025	15
DFT0704..	191.698	170.025	15

D	LS	CS
32	58	R 1/4 BSP
40	68	R 1/4 BSP

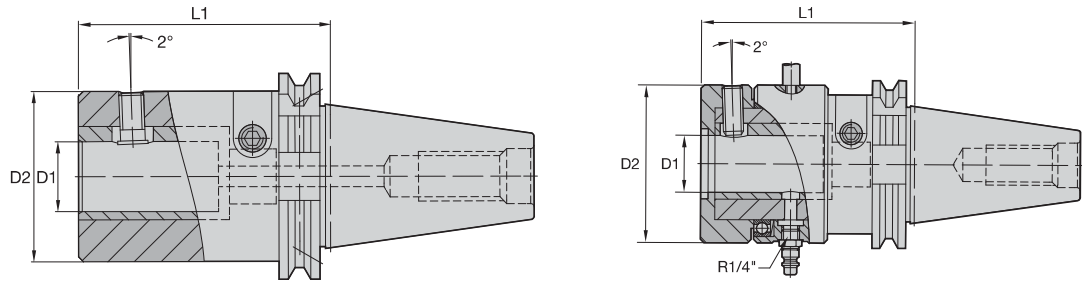





■ Drill Fix Chucks • Eccentric Adjustment Mechanism



catalogue number	D1	D2	L1	SK 40		SK 50		coolant ring	kg	lbs
				DIN 69871 A	MAS 403 BT	DIN 69871 A	MAS 403 BT			
BT40BEWD20096M	20,00	63.000	96.000	—	●	—	—	—	3.00	6.6
DV40BEWD20090M	20,00	63.000	96.000	●	—	—	—	—	3.00	6.6
DV50BEWD32108M	32,00	63.000	108.000	—	—	●	—	—	4.30	9.5
BT50BEWD32127M	32,00	63.000	108.000	—	—	—	●	—	4,3	9.5
DV40BEWD32108M	32,00	63.000	108.000	●	—	—	—	—	4.00	8.8
BT40BEWD32114M	32,00	63.000	114.000	—	●	—	—	—	3.40	7.5
BT40RMEWD32114M	32,00	90.000	114.000	—	●	—	—	●	4.00	8.8
DV50RMEWD32108M	32,00	90.000	108.000	—	—	●	—	●	6.90	15.2

NOTE: n_{max} : 4800 U/min
 P_{max} : 20 bar

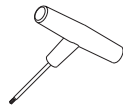
■ With Coolant Ring

D1	 clamping screw	 adjusting screw	 bumper bar	 eccentric bushing	 dial key
32	192.941	570.850	169.974	536.088	170.236

■ Without Coolant Ring

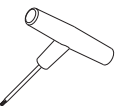
D1	 clamping screw	 adjusting screw	 eccentric bushing	 dial key
20	193.203	570.850	536.090	170.236
32	193.204	570.850	536.091	170.236

SAFETY NOTE: Use only the supplied plug-in nipple with nominal breakage point: R 6,35mm, catalogue number 191.469.
Intermediate sleeve with dial key included (for coolant ring version, use dial key, bumper bar, and plug-in nipple with predetermined breaking point).

■ Drill Fix™ DFT™ • Metric



Material Group		Condition	Pocket Seat	Geometry	Grade	Metric									
						Cutting Speed – vc			Recommended Feed Rate (f) by Diameter						
						min	Starting Value	max	Ø	DFT03 16–24mm	DFT05 25–32mm	DFT06 32–40mm	DFT07 41–48mm	DFT09... 49–68mm	DFT11 69–82mm
P	0	S	O	DS	KCU40	280	300	320	mm/r	0,05–0,08	0,07–0,12	0,09–0,15	0,13–0,21	0,17–0,27	0,17–0,27
			I	DS	KCU40										
		U	O	DS	KCU40	200	215	230	mm/r	0,05–0,08	0,07–0,12	0,09–0,15	0,13–0,21	0,17–0,27	0,17–0,27
	I		DS	KCU40											
	1	S	O	MD	KCU25	310	325	360	mm/r	0,05–0,08	0,07–0,12	0,09–0,15	0,13–0,21	0,17–0,27	0,19–0,31
			I	MD	KC7140										
		U	O	MD	KCU25	200	215	230	mm/r	0,06–0,10	0,09–0,15	0,11–0,18	0,15–0,25	0,19–0,31	0,19–0,31
	I		MD	KC7140											
	2	S	O	HP	KCPK10	310	325	360	mm/r	0,06–0,10	0,09–0,15	0,11–0,18	0,15–0,25	0,19–0,31	0,19–0,31
			I	HP	KC7140										
		U	O	HP	KCU25	200	215	230	mm/r	0,06–0,10	0,09–0,15	0,11–0,18	0,15–0,25	0,19–0,31	0,19–0,31
	I		HP	KC7140											
	3	S	O	HP	KCPK10	260	285	320	mm/r	0,06–0,10	0,09–0,15	0,11–0,18	0,15–0,25	0,19–0,31	0,19–0,31
			I	HP	KC7140										
		U	O	HP	KCU25	180	195	220	mm/r	0,06–0,10	0,09–0,15	0,11–0,18	0,15–0,25	0,19–0,31	0,19–0,31
	I		HP	KC7140											
	4	S	O	HP	KCU25	220	250	300	mm/r	0,06–0,10	0,09–0,15	0,11–0,18	0,15–0,25	0,19–0,31	0,19–0,31
			I	HP	KC7140										
		U	O	HP	KCU40	150	180	220	mm/r	0,06–0,10	0,09–0,15	0,11–0,18	0,15–0,25	0,19–0,31	0,19–0,31
	I		HP	KC7140											
	5	S	O	HP	KCU25	180	200	220	mm/r	0,06–0,10	0,07–0,13	0,09–0,15	0,11–0,18	0,12–0,23	0,12–0,23
			I	HP	KC7140										
		U	O	HP	KCU40	120	135	150	mm/r	0,06–0,10	0,07–0,13	0,09–0,15	0,11–0,18	0,12–0,23	0,12–0,23
	I		HP	KC7140											
6	S	O	HP	KCU25	180	200	220	mm/r	0,05–0,10	0,07–0,13	0,09–0,15	0,11–0,18	0,12–0,23	0,12–0,23	
		I	HP	KC7140											
	U	O	HP	KCU40	120	135	150	mm/r	0,05–0,10	0,07–0,13	0,09–0,15	0,11–0,18	0,12–0,23	0,12–0,23	
I		HP	KC7140												
M	1	S	O	DS	KCU40	150	190	230	mm/r	0,05–0,08	0,05–0,10	0,06–0,13	0,08–0,14	0,09–0,17	0,09–0,17
			I	DS	KCU40										
		U	O	DS	KCU40	100	130	160	mm/r	0,05–0,08	0,05–0,10	0,06–0,13	0,08–0,14	0,09–0,17	0,09–0,17
	I		DS	KCU40											
	2	S	O	MD	KC7140	60	80	100	mm/r	0,05–0,08	0,05–0,10	0,06–0,13	0,08–0,14	0,09–0,17	0,09–0,17
			I	MD	KC7140										
		U	O	DS	KCU40	150	180	210	mm/r	0,05–0,08	0,05–0,10	0,06–0,13	0,08–0,14	0,09–0,17	0,09–0,17
	I		DS	KCU40											
	3	S	O	MD	KC7140	60	80	100	mm/r	0,05–0,08	0,05–0,10	0,06–0,13	0,08–0,14	0,09–0,17	0,09–0,17
			I	MD	KC7140										
		U	O	DS	KCU40	100	130	160	mm/r	0,05–0,08	0,05–0,10	0,06–0,13	0,08–0,14	0,09–0,17	0,09–0,17
	I		DS	KCU40											
3	S	O	HP	KCU40	80	110	140	mm/r	0,05–0,08	0,05–0,10	0,06–0,13	0,08–0,14	0,09–0,17	0,09–0,17	
		I	HP	KC7140											
	U	O	MD	KC7140	50	70	90	mm/r	0,05–0,08	0,05–0,10	0,06–0,13	0,08–0,14	0,09–0,17	0,09–0,17	
I		MD	KC7140												

Condition: S = Stable cutting conditions;
 U = Unstable cutting conditions;
 I = Interrupted cutting conditions

Pocket seat: I = Inboard insert;
 O = Outboard insert

Drill Fix™ DFT™ • Metric

		Metric													
Material Group	Condition	Pocket Seat	Geometry	Grade	Cutting Speed – vc			Recommended Feed Rate (f) by Diameter							
					Range – m/min			Ø	DFT03 16–24mm	DFT05 25–32mm	DFT06 32–40mm	DFT07 41–48mm	DFT09... 49–68mm	DFT11 69–82mm	
					min	Starting Value	max								
K	1	S	O HP	KCPK10	200	240	300	mm/r	0,08–0,13	0,10–0,18	0,14–0,26	0,18–0,33	0,21–0,39	0,21–0,39	
			I HP	KCU40											
		U	O HP	KCU25	120	155	200	mm/r	0,08–0,13	0,10–0,18	0,14–0,26	0,18–0,33	0,21–0,39	0,21–0,39	
	I HP		KCU40												
	2	S	O HP	KCPK10	180	220	260	mm/r	0,08–0,13	0,10–0,18	0,14–0,26	0,18–0,33	0,21–0,39	0,21–0,39	
			I HP	KCU40											
		U	O HP	KCU25	110	140	170	mm/r	0,08–0,13	0,10–0,18	0,14–0,26	0,18–0,33	0,21–0,39	0,21–0,39	
	I HP		KC7140												
	3	S	O HP	KCPK10	180	220	260	mm/r	0,08–0,13	0,10–0,18	0,14–0,26	0,18–0,33	0,21–0,39	0,21–0,39	
I HP			KCU40												
U		O HP	KCU25	110	140	170	mm/r	0,08–0,13	0,10–0,18	0,14–0,26	0,18–0,33	0,21–0,39	0,21–0,39		
	I HP	KC7140													
N	1	S	O ST	KD1425	400	600	800	mm/r	0,05–0,07	0,07–0,09	0,10–0,14	0,12–0,16	0,14–0,18	0,14–0,18	
			I ST	KD1425											
		U	O HP	KCU40	300	400	500	mm/r	0,05–0,07	0,07–0,09	0,10–0,14	0,12–0,16	0,14–0,18	0,14–0,18	
	I HP		KCU40												
	2	S	O ST	KD1425	375	550	775	mm/r	0,05–0,07	0,07–0,09	0,10–0,14	0,12–0,16	0,14–0,18	0,14–0,18	
			I ST	KD1425											
		U	O HP	KCU40	250	350	450	mm/r	0,05–0,07	0,07–0,09	0,10–0,14	0,12–0,16	0,14–0,18	0,14–0,18	
	I HP		KCU40												
	3	S	O ST	KD1425	350	500	650	mm/r	0,05–0,07	0,07–0,09	0,10–0,14	0,12–0,16	0,14–0,18	0,14–0,18	
			I ST	KD1425											
		U	O HP	KCU40	250	350	450	mm/r	0,05–0,07	0,07–0,09	0,10–0,14	0,12–0,16	0,14–0,18	0,14–0,18	
	I HP		KCU40												
	4	S	O ST	KD1425	400	600	800	mm/r	0,05–0,07	0,07–0,09	0,10–0,14	0,12–0,16	0,14–0,18	0,14–0,18	
			I ST	KD1425											
		U	O HP	KCU40	250	350	450	mm/r	0,05–0,07	0,07–0,09	0,10–0,14	0,12–0,16	0,14–0,18	0,14–0,18	
	I HP		KCU40												
	5	S	O ST	KD1425	400	600	800	mm/r	0,05–0,07	0,07–0,09	0,10–0,14	0,12–0,16	0,14–0,18	0,14–0,18	
			I ST	KD1425											
		U	O HP	KCU40	250	350	450	mm/r	0,05–0,07	0,07–0,09	0,10–0,14	0,12–0,16	0,14–0,18	0,14–0,18	
	I HP		KCU40												
	6	S	O ST	KD1425	400	600	800	mm/r	0,05–0,07	0,07–0,09	0,10–0,14	0,12–0,16	0,14–0,18	0,14–0,18	
			I ST	KD1425											
		U	O HP	KCU40	250	350	450	mm/r	0,05–0,07	0,07–0,09	0,10–0,14	0,12–0,16	0,14–0,18	0,14–0,18	
	I HP		KCU40												
7	S	O ST	KD1425	400	600	800	mm/r	0,05–0,07	0,07–0,09	0,10–0,14	0,12–0,16	0,14–0,18	0,14–0,18		
		I ST	KD1425												
	U	O HP	KCU40	250	350	450	mm/r	0,05–0,07	0,07–0,09	0,10–0,14	0,12–0,16	0,14–0,18	0,14–0,18		
I HP		KCU40													
8	S	O ST	KD1425	400	600	800	mm/r	0,05–0,07	0,07–0,09	0,10–0,14	0,12–0,16	0,14–0,18	0,14–0,18		
		I ST	KD1425												
	U	O HP	KCU40	250	350	450	mm/r	0,05–0,07	0,07–0,09	0,10–0,14	0,12–0,16	0,14–0,18	0,14–0,18		
I HP		KCU40													

Condition: S = Stable cutting conditions;
 U = Unstable cutting conditions;
 I = Interrupted cutting conditions

Pocket seat: I = Inboard insert;
 O = Outboard insert



■ Drill Fix™ DFT™ • Metric

		Metric													
Material Group	Condition	Pocket Seat	Geometry	Grade	Cutting Speed – vc			Recommended Feed Rate (f) by Diameter							
					Range – m/min			Ø	DFT03 16–24mm	DFT05 25–32mm	DFT06 32–40mm	DFT07 41–48mm	DFT09... 49–68mm	DFT11 69–82mm	
					min	Starting Value	max								
S	1	S	O	HP	KCU40	60	70	75	mm/r	0,03–0,05	0,04–0,06	0,05–0,08	0,06–0,1	0,08–0,13	0,08–0,13
			I	HP	KCU40										
	U	O	HP	KCU40	40	50	60	mm/r	0,03–0,05	0,04–0,06	0,05–0,08	0,06–0,1	0,08–0,13	0,08–0,13	
		I	HP	KC7140											
	I	O	MD	KC7140	25	30	40	mm/r	0,03–0,05	0,04–0,06	0,05–0,08	0,06–0,1	0,08–0,13	0,08–0,13	
		I	MD	KC7140											
	2	S	O	HP	KCU40	50	60	70	mm/r	0,05–0,07	0,05–0,07	0,05–0,08	0,06–0,1	0,07–0,12	0,07–0,12
			I	HP	KCU40										
		U	O	HP	KCU40	30	40	50	mm/r	0,04–0,06	0,05–0,08	0,06–0,10	0,06–0,1	0,09–0,15	0,09–0,15
			I	HP	KC7140										
	I	O	MD	KC7140	25	30	40	mm/r	0,05–0,07	0,05–0,07	0,05–0,08	0,06–0,1	0,07–0,12	0,07–0,12	
		I	MD	KC7140											
	3	S	O	HP	KCU40	70	80	90	mm/r	0,03–0,05	0,04–0,06	0,05–0,08	0,06–0,1	0,08–0,13	0,08–0,13
			I	HP	KCU40										
		U	O	HP	KCU40	50	60	70	mm/r	0,03–0,05	0,04–0,06	0,05–0,08	0,06–0,1	0,08–0,13	0,08–0,13
			I	HP	KCU40										
I	O	MD	KC7140	30	40	50	mm/r	0,03–0,05	0,04–0,06	0,05–0,08	0,06–0,1	0,08–0,13	0,08–0,13		
	I	MD	KC7140												
4	S	O	HP	KCU40	70	80	90	mm/r	0,05–0,07	0,05–0,07	0,05–0,08	0,06–0,1	0,07–0,12	0,07–0,12	
		I	HP	KCU40											
	U	O	HP	KCU40	50	60	70	mm/r	0,04–0,06	0,05–0,08	0,06–0,10	0,06–0,1	0,09–0,15	0,09–0,15	
		I	HP	KCU40											
I	O	MD	KC7140	30	40	50	mm/r	0,05–0,07	0,05–0,07	0,05–0,08	0,06–0,1	0,07–0,12	0,07–0,12		
	I	MD	KC7140												

Condition: S = Stable cutting conditions;
 U = Unstable cutting conditions;
 I = Interrupted cutting conditions

Pocket seat: I = Inboard insert;
 O = Outboard insert



The Most Cost-Effective
Way to Drill a Hole...

Indexable Drilling with Drill Fix™ DFSP™



COST-EFFECTIVE INSERTS

Versatile squared outboard inserts have four economic cutting edges to achieve high metal removal rates and excellent chip evacuation.











ONE COMPREHENSIVE PLATFORM

Standard diameter range covering 14–55mm (.551–2.125") in 2 x D, 3 x D, 4 x D, and 5 x D.

WIDE RANGE OF MATERIALS



APPLICATION CAPABILITIES

 Drilling into Solid	 Drilling: Inclined Entry	 Drilling: Inclined Exit	 Drilling: X-Offset	 Drilling: Convex
 Drilling: Blind	 Chain Drilling	 Drilling: Cross Hole	 Drilling: Half Cylinder	 Drilling: Corner Drilling 45°

Experience the advantages at your Authorised Kennametal Distributor or at kennametal.com.



kennametal.com

➤ HTS Series Indexable Deep-Hole Drilling System

Primary Application

HTS series indexable drills are designed for deep-hole drilling up to 10 x D in steel, stainless steel, ductile iron, cast iron, and non-ferrous materials. The two HTS systems — HTS and HTS-R — cover a diameter range of 40–270mm (1.575–10.629").



Features and Benefits

HTS Indexable Drill System

- Large diameter range from 45–270mm (1.750–10.629") with standard drill heads.
- Drill Fix™ DFT™ trigon inserts as outboard and inboard insert offer the best centring capabilities; square-outboard insert cartridges offer increased surface and hole quality.
- Various insert geometries and grades available as standard.
- Adjust drilling depth and diameter range with suitable extensions and reducers.
- Diameter adjustment by shortening outer cartridge.
- Customised drilling heads up to 540mm (21.259").



HTS-R Indexable Drill System

- Modular system uses drill heads equipped with DFR™ insert cartridges.
- Five drill heads cover the diameter range 40–55mm (1.575–2.165").
- Drill Fix™ DFR rectangular inboard and outboard inserts offer the highest feed rates at small diameters.
- Various insert geometries and grades available as standard.
- Adjust drilling depth and diameters by using extensions and reducers.
- Diameter adjustment by shortening outer cartridge.

➤ HTS Indexable Drill System

The HTS indexable drill system is one of the most reliable deep-hole drilling systems available. Drilling up to 10 x D can be easily achieved in materials like steel, stainless steel, ductile iron, cast iron, and non-ferrous materials. Various drilling heads cover the diameter range 45–270mm (1.77–10.63").

HTS drill heads are equipped with pilot drills and cartridges using trigon-shaped Drill Fix™ DFT™ inserts. Use HTS extensions and reducers to achieve various diameters and depths of drilling.

For improved surface qualities and increased reliability, finishing HTS cartridges with a squared-outboard insert are available as standard.

Features and Benefits

Productivity

- Achieve high hole accuracy by using pilot drills and trigon-shaped inserts.
- Benefit from improved surface qualities using finishing cartridges with squared-outboard inserts.
- Adjust outer cartridge to desired cutting diameter, reducing inventory.
- Same insert size is used in each insert cartridge, reducing inventory costs.

Versatility

- Diameter range covering 45–270mm (1.77–10.63").
- L/D ratio up to 10 x D as standard.
- Inserts and pilot drills can be used with various heads and cartridges, covering various diameters.
- Large variety of DFT insert grades and geometries available.
- Finishing cartridge with squared-outboard insert offering four cutting edges for high process stability.
- Carbide pilot drills are available upon request.

Use HTS extensions and reducers to achieve various diameters and depths of drilling.

Customisation

- Wear pads can be added for increased stability.
- Fully engineered solutions available.
- Custom solutions covering diameter range up to 540mm (21.259") are possible.



➤ HTS-R Indexable Drill System

HTS-R extends the HTS system by covering diameters between 40–55mm (1.575–2.165").

Up to 30% higher feed rates achievable with rectangular-shaped Drill Fix™ DFR™ inserts with the added benefit of improved chip control.

Features and Benefits

Productivity

- Benefit from better chip control and higher insert stability for longer tool body life.
- Same insert size is used in each insert cartridge.

Versatility

- Diameter range covering 40–55mm (1.575–2.165") with five drilling heads.
- Large variety of DFR insert grades and geometries available.
- Outer cartridges can be adjusted to the desired cutting diameter.
- Extensions and reducers are available as standard.
- Solid carbide and HSS pilot drills are available to match the cutting conditions of specific applications.

Benefit from better chip control and higher insert stability for longer tool body life.



Pilot drill should be installed and set to the proper length before installing the inner cartridge.



Install inner cartridge, then the outer insert.



Install inner insert into cartridge.

Customisation

- Wear pads can be added for increased stability.
- Fully engineered solutions available.



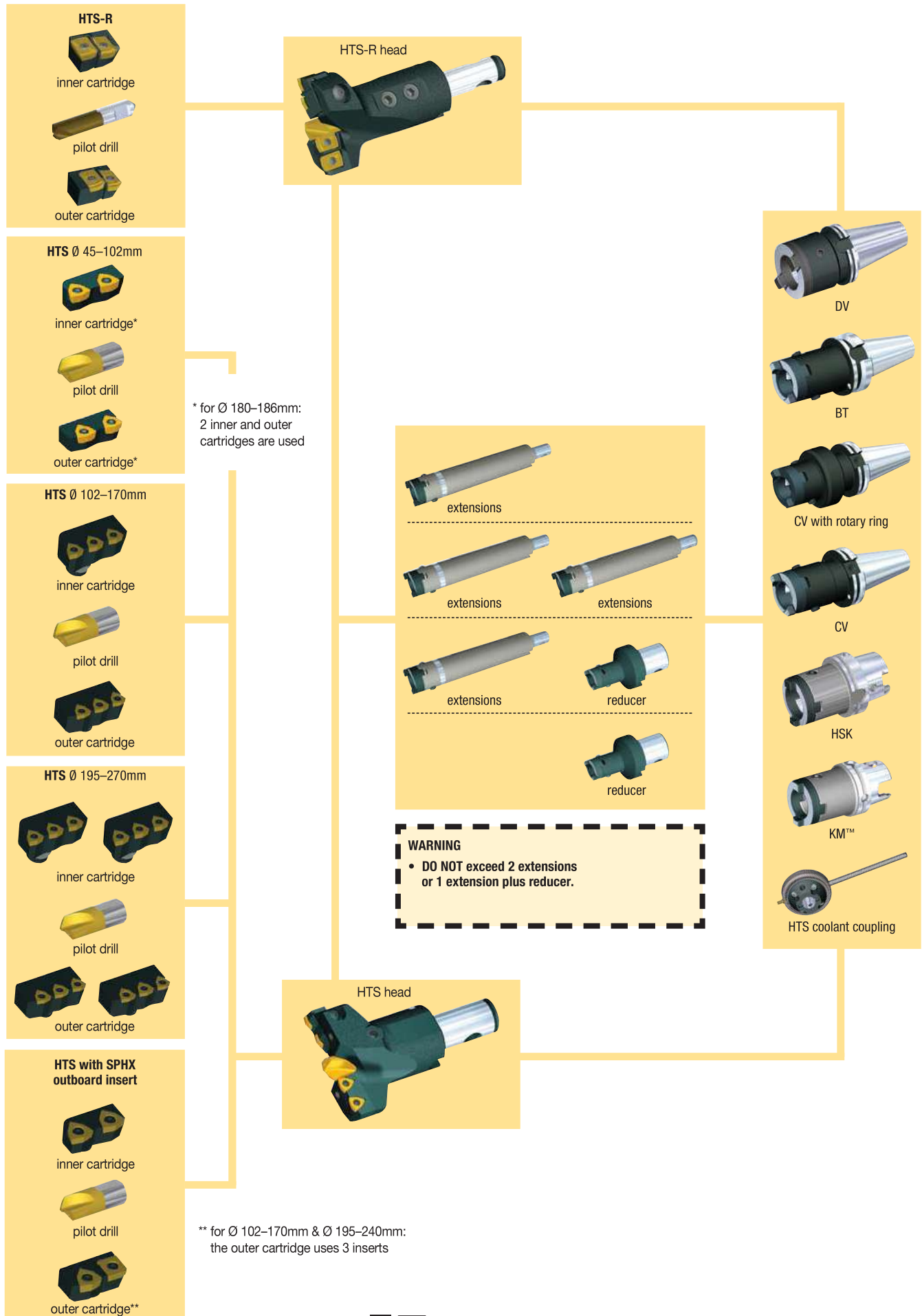

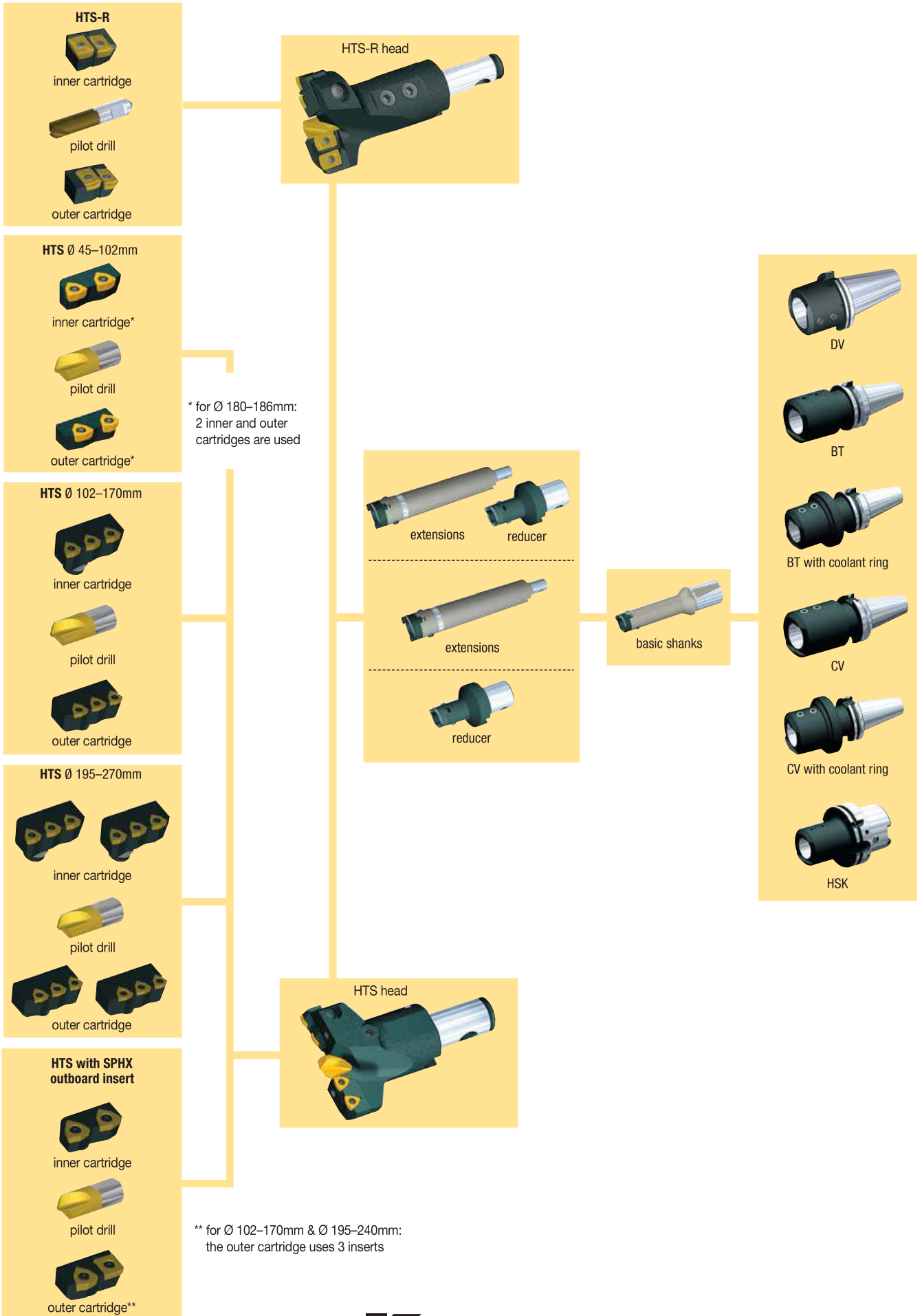

To assemble your HTS(-R) head, choose the desired drill diameter range from the left-hand column.

Next, follow the columns to the right, and select the appropriate component from each column to complete your HTS(-R) head.

drilling range		HTS head	L1		HTS(-R) head with DFR™/DFT™ inserts								
					inner cartridge				outer cartridge				
mm	in		mm	in	cartridge	n	insert	n	cartridge	n	insert	n	pilot drill
40–43	1.57–1.69	HTSR040R025M	60	2.36	HTSR10CI	1	DFR0302.	2	HTSR10CE	1	DFR0302.	2	B513S08.
43–46	1.69–1.81	HTSR043R025M	70	2.76	HTSR11CI	1	DFR0302.	2	HTSR11CE	1	DFR0302.	2	B513S10.
46–49	1.81–1.93	HTSR046R028M			HTSR12CI	1	DFR0403.	2	HTSR12CE	1	DFR0403.	2	B513S10.
49–52	1.93–2.05	HTSR049R028M			HTSR13CI	1	DFR0403.	2	HTSR13CE	1	DFR0403..	2	B513S10.
52–55	2.05–2.17	HTSR052R028M			HTSR14CI	1	DFR0403.	2	HTSR14CE	1	DFR0403..	2	B513S10.

drilling range		HTS head	L1		HTS(-R) head with DFR™/DFT™ inserts									
					inner cartridge				outer cartridge					
mm	in		mm	in	cartridge	n	insert	n	cartridge	n	insert	n	pilot drill	
45–50	1.77–1.97	3.76045R028V	50	1.97	3.77000R050V	1	DFT0303.	2	3.77000R051V	1	DFT0303.	2	B510S08.	
50–55	1.97–2.17	3.76050R028V			3.77000R052V	1	DFT0303.	2	3.77000R053V	1	DFT0303.	2	B510S08.	
55–58	2.17–2.28	3.76055R032V	60	2.36	3.77000R038V	1	DFT05T3.	2	3.77000R039V	1	DFT05T3.	2	B510S08.	
58–63	2.28–2.48	3.76058R032V			3.77000R023V	1	DFT05T3.	2	3.77000R024V	1	DFT05T3.	2	B510S10.	
63–68	2.48–2.68	3.76063R032V			3.77000R025V	1	DFT05T3.	2	3.77000R024V	1	DFT05T3.	2	B510S10.	
63–68	2.48–2.68	3.76063R040V*			70	2.76	3.77000R025V	1	DFT05T3.	2	3.77000R024V	1	DFT05T3.	2
68–73	2.68–2.87	3.76068R040V	3.77000R026V	1			DFT05T3.	2	3.77000R027V	1	DFT05T3.	2	B510S10.	
73–78	2.87–3.07	3.76073R040V	3.77000R026V	1			DFT05T3.	2	3.77000R027V	1	DFT05T3.	2	B510S15.	
78–84	3.07–3.31	3.76078R040V	3.77000R028V	1			DFT06T3.	2	3.77000R029V	1	DFT06T3.	2	B510S15.	
78–84	3.07–3.31	3.76078R048V*	70	2.76	3.77000R028V	1	DFT06T3.	2	3.77000R029V	1	DFT06T3.	2	B510S15.	
84–90	3.31–3.54	3.76084R048V			3.77000R028V	1	DFT06T3.	2	3.77000R029V	1	DFT06T3.	2	B510S15.	
90–94°	3.54–3.70	3.76090R048V			–	–	–	–	–	–	–	–	–	–
90–96	3.54–3.78	3.76090R048V			3.77000R030V	1	DFT06T3.	2	3.77000R031V	1	DFT06T3.	2	B510S15.	
96–100°	3.78–3.93	3.76096R048V	80	3.15	–	–	–	–	–	–	–	–	–	
96–102	3.78–4.02	3.76096R048V			3.77000R030V	1	DFT06T3.	2	3.77000R031V	1	DFT06T3.	2	B510S20.	
96–100°	3.78–3.93	3.76096R058V*			–	–	–	–	–	–	–	–	–	–
96–102	3.78–4.02	3.76096R058V*			3.77000R030V	1	DFT06T3.	2	3.77000R031V	1	DFT06T3.	2	B510S20.	
102–108	4.02–4.25	3.76102R058V	90	3.54	3.77000R081V	1	DFT05T3.	3	3.77000R082V	1	DFT05T3.	3	B510S20.	
108–115	4.25–4.53	3.76108R058V			3.77000R083V	1	DFT06T3.	3	3.77000R084V	1	DFT06T3.	3	B510S20.	
115–122	4.53–4.80	3.76115R070V			3.77000R085V	1	DFT06T3.	3	3.77000R086V	1	DFT06T3.	3	B510S25.	
122–130	4.80–5.12	3.76122R070V	100	3.94	3.77000R079V	1	DFT06T3.	3	3.77000R080V	1	DFT06T3.	3	B510S25.	
130–140	5.12–5.51	3.76130R070V			3.77000R087V	1	DFT06T3.	3	3.77000R088V	1	DFT06T3.	3	B510S25.	
140–150	5.51–5.91	3.76140R080V			3.77000R077V	1	DFT0704.	3	3.77000R078V	1	DFT0704.	3	B510S25.	
150–158	5.91–6.22	3.76150R080V			3.77000R075V	1	DFT0704.	3	3.77000R076V	1	DFT0704.	3	B510S25.	
158–162	6.22–6.38	3.76158R080V	125	4.92	3.77000R073V	1	DFT0704.	3	3.77000R074V	1	DFT0704.	3	B510S25.	
162–170	6.38–6.70	3.76162R080V			3.77000R048V	1	DFT0704.	3	3.77000R049V	1	DFT0704.	3	B510S30.	
180–184°	7.08–7.24	3.76180R110			–	–	–	–	–	–	–	–	–	–
180–186	7.08–7.32	3.76180R110			3.77000R030V	3	DFT06T3.	4	3.77000R031V	1	DFT06T3.	4	B510S30.	
195–201	7.68–7.91	3.76195R110	150	5.91	3.77000R081V	3	DFT05T3.	6	3.77000R082V	1	DFT05T3.	6	B510S30.	
213–220	8.39–8.66	3.76213R125			3.77000R083V	3	DFT06T3.	6	3.77000R084V	1	DFT06T3.	6	B510S30.	
230–240	9.06–9.45	3.76230R160	150	5.91	3.77000R079V	2	DFT06T3.	6	3.77000R080V	2	DFT06T3.	6	B510S30.	
260–270	10.24–10.63	3.76260R160			3.77000R077V	2	DFT06T3.	6	3.77000R078V	2	DFT06T3.	6	B510S30.	

° Decreased diameter range by using SPHX insert in exterior cartridge.

* Drill heads with reinforced body for short-chipping materials.

n = Required quantity.

HTS head with DFT™ inserts and SPHX outboard insert													
inner cartridge							outer cartridge						pilot drill
cartridge	n	cartridge	n	insert	n	cartridge	n	insert	n	insert	n	pilot drill	
-	-	-	-	-	-	-	-	-	-	-	-	-	-
-	-	-	-	-	-	-	-	-	-	-	-	-	-
-	-	-	-	-	-	-	-	-	-	-	-	-	-
-	-	-	-	-	-	-	-	-	-	-	-	-	-
-	-	-	-	-	-	-	-	-	-	-	-	-	-

3.77000R250V	1	-	-	DFT0303.	2	3.77000R251V	1	DFT0303.	1	SPHX0703.	1	B510S08.
3.77000R252V	1	-	-	DFT0303.	2	3.77000R253V	1	DFT0303.	1	SPHX0703.	1	B510S08.
3.77000R038V	1	-	-	DFT05T3.	2	3.77000R239V	1	DFT05T3.	1	SPHX0903.	1	B510S08.
3.77000R023V	1	-	-	DFT05T3.	2	3.77000R224V	1	DFT05T3.	1	SPHX0903.	1	B510S10.
3.77000R025V	1	-	-	DFT05T3.	2	3.77000R224V	1	DFT05T3.	1	SPHX0903.	1	B510S10.
3.77000R025V	1	-	-	DFT05T3.	2	3.77000R224V	1	DFT05T3.	1	SPHX0903.	1	B510S10.
3.77000R026V	1	-	-	DFT05T3.	2	3.77000R227V	1	DFT05T3.	1	SPHX0903.	1	B510S10.
3.77000R026V	1	-	-	DFT05T3.	2	3.77000R227V	1	DFT05T3.	1	SPHX0903.	1	B510S15.
3.77000R028V	1	-	-	DFT06T3.	2	3.77000R229V	1	DFT06T3.	1	SPHX0903.	1	B510S15.
3.77000R028V	1	-	-	DFT06T3.	2	3.77000R229V	1	DFT06T3.	1	SPHX0903.	1	B510S15.
3.77000R228V	1	-	-	DFT06T3.	2	3.77000R229V	1	DFT06T3.	1	SPHX0903.	1	B510S15.
3.77000R230V	1	-	-	DFT06T3.	2	3.77000R231V	1	DFT06T3.	1	SPHX0903.	1	B510S15.
-	-	-	-	-	-	-	-	-	-	-	-	-
3.77000R230V	1	-	-	DFT06T3.	2	3.77000R231V	1	DFT06T3.	1	SPHX0903.	1	B510S20.
-	-	-	-	-	-	-	-	-	-	-	-	-
3.77000R230V	1	-	-	DFT06T3.	2	3.77000R231V	1	DFT06T3.	1	SPHX0903.	1	B510S20.
-	-	-	-	-	-	-	-	-	-	-	-	-
3.77000R081V	1	-	-	DFT05T3.	3	3.77000R282V	1	DFT05T3.	2	SPHX0903.	1	B510S20.
3.77000R083V	1	-	-	DFT06T3.	3	3.77000R284V	1	DFT06T3.	2	SPHX1204.	1	B510S20.
3.77000R085V	1	-	-	DFT06T3.	3	3.77000R286V	1	DFT06T3.	2	SPHX1204.	1	B510S25.
3.77000R079V	1	-	-	DFT06T3.	3	3.77000R280V	1	DFT06T3.	2	SPHX1204.	1	B510S25.
3.77000R087V	1	-	-	DFT06T3.	3	3.77000R288V	1	DFT06T3.	2	SPHX1204.	1	B510S25.
3.77000R077V	1	-	-	DFT0704.	3	3.77000R278V	1	DFT0704.	2	SPHX1505.	1	B510S25.
3.77000R075V	1	-	-	DFT0704.	3	3.77000R276V	1	DFT0704.	2	SPHX1204.	1	B510S25.
3.77000R073V	1	-	-	DFT0704.	3	3.77000R274V	1	DFT0704.	2	SPHX1204.	1	B510S25.
3.77000R248V	1	-	-	DFT0704.	3	3.77000R249V	1	DFT0704.	2	SPHX1505.	1	B510S30.
3.77000R230V	3	-	-	DFT06T3.	4	3.77000R231V	1	DFT06T3.	3	SPHX0903.	1	B510S30.
-	-	-	-	-	-	-	-	-	-	-	-	-
3.77000R081V	3	-	-	DFT05T3.	9	3.77000R282V	1	DFT05T3.	2	SPHX0903.	1	B510S30.
3.77000R083V	3	-	-	DFT06T3.	9	3.77000R284V	1	DFT06T3.	2	SPHX1204.	1	B510S30.
3.77000R079V	2	3.77000R080V	1	DFT06T3.	9	3.77000R280V	1	DFT06T3.	2	SPHX1204.	1	B510S30.
-	-	-	-	-	-	-	-	-	-	-	-	B510S30

HTS Tool Assembly Combinations

- Select your appropriate drill diameter range.
- Choose the appropriate adaptor and shank size.
- Follow the columns to the right, and select the appropriate components from each column to complete your HTS(-R) tool.

drilling range		shank		DV		BT		CV		HSK			
				assembly details		assembly details		assembly details		assembly details			
mm	in		D1	40	50	40	50	40	50	50/63/100			
HTS heads with DFR™ inserts	40–43 43–46	1.57–1.69 1.69–1.81	WD/ WN	32	DV40BWD32075M DV40RMWD32115M**	DV50BWD32060M DV50RMWD32140M**	BT40BWD32070M	BT50BWD32080M	CV40BWD32M343 CV40RMWD32M453**	CV50BWD32M343 CV50RMWD32M453**	HSK50ASWN32110M HSK63ASWN32090M HSK100ASWN32100M		
				50	–	DV50BWD50075M DV50RMWD50144M**	–	BT50BWD50085M BT50RMWD50162M**	–	CV50BWD50M343 CV50RMWD50M472**	–		
	46–49 49–52 52–55	1.81–1.93 1.93–2.05 2.05–2.17	SS(F)	1.50	–	–	–	–	CV40BSSF150575	CV50SS150400 (AD) CV50SS150600 (AD) CV50SS150800 (AD) CV50BSSF150450	–	–	
				HTS	50	–	5.36050–154050	–	BT50BHTS50080M	–	CV50BHTS50M314 CV50RMHTS50M413**	–	–
	HTS heads with DFT™/SPHX inserts	45–50 50–55	1.77–1.97 1.97–2.17	WD/ WN	32	DV40BWD32075M DV40RMWD32115M**	DV50BWD32060M DV50RMWD32140M**	BT40BWD32070M	BT50BWD32080M	CV40BWD32M343 CV40RMWD32M453**	CV50BWD32M343 CV50RMWD32M453**	HSK50ASWN32110M HSK63ASWN32090M HSK100ASWN32100M	
					50	–	DV50BWD50075M DV50RMWD50144M**	–	BT50BWD50085M BT50RMWD50162M**	–	CV50BWD50M343 CV50RMWD50M472**	HSK100ASWN50110M	
		55–58 58–63 63–68	2.17–2.28 2.28–2.48 2.48–2.68	SS(F)	2.00	–	–	–	–	–	CV50SS200562 (AD) CV50SS200762 (AD) CV50BSSF200550	–	–
					HTS	50	–	5.36050–154050	–	BT50BHTS50080M	–	CV50BHTS50M314 CV50RMHTS50M413**	–
63–68* 68–73 73–78 78–84		2.48–2.68 2.68–2.87 2.87–3.07 3.07–3.31	WD/ WN	50	–	DV50BWD50075M DV50RMWD50144M**	–	BT50BWD50085M BT50RMWD50162M**	–	CV50BWD50M343 CV50RMWD50M472**	–	HSK100ASWN50110M	
				SS(F)	2.00	–	–	–	–	–	V50SS200562 (AD) CV50SS200762 (AD) CV50BSSF200550	–	–
63–68* 68–73 73–78 78–84		2.48–2.68 2.68–2.87 2.87–3.07 3.07–3.31	HTS	50	–	5.36050–154050	–	BT50BHTS50080M	–	CV50BHTS50M314 CV50RMHTS50M413**	–	–	
				HTS	50	–	5.36050–154050	–	BT50BHTS50080M	–	CV50BHTS50M314 CV50RMHTS50M413**	–	–

* HTS drilling head with reinforced body for short-chipping materials.

** Adaptor with coolant ring.

The shown combinations are not complete. Ask your Kennametal representative to get the most reasonable solution for your application.

Please note that the assembled total length of the drilling tool is not necessarily the total achievable drilling depth.

KM™	basic shank					reducer			for use with coolant adaptor		extension			HTS head
	assembly details	L4	L4	L4	L4	L1					L1			
80	metric	mm	inch	in		mm	in	coolant adaptor	shell mill DV/BT		mm	in		
-	5.34032-025115 5.34032-025200	110 195	-	-	-	-	-	-	-	-	-	-	-	-
-	5.34050-025300 5.34050-025450	270 420	-	-	-	-	-	-	-	-	5.34125R025150	160	6.30	HTSR040R025M HTSR043R025M
-	-	-	-	SSF150HTS130239 SSF150HTS130664 SSF150HTS131114 SSF150HTS131764	.39 4.65 9.14 15.64	-	-	-	-	-	-	-	-	-
-	5.34032-028115 5.34032-028200	110 195	-	-	-	-	-	-	-	-	-	-	-	-
-	5.34050-028300 5.34050-028450	265 415	-	-	-	-	-	-	-	-	-	-	-	-
-	-	-	-	SSF200HTS130239 SSF200HTS130664 SSF200HTS131114 SSF200HTS131764	.39 4.65 9.14 15.64	-	-	-	-	-	5.34128R028150	160	6.30	HTSR046R028M HTSR049R028M HTSR052R028M
KM80ATCHTS50085M KM80ATCHTS50100M	-	-	-	-	-	5.34280R028080	90	3.54	5.34350-090100	DV50SM60070M BT50SM60090M	-	-	-	-
-	5.34032-025115 5.34032-025200	110 195	-	-	-	-	-	-	-	-	-	-	-	-
-	5.34050-028300 5.34050-028450	265 415	-	-	-	-	-	-	-	-	5.34128R028150	160	6.30	3.76045R028V 3.76050R028V
-	-	-	-	SSF200HTS130239 SSF200HTS130664 SSF200HTS131114 SSF200HTS131764	.39 4.65 9.14 15.64	-	-	-	-	-	-	-	-	-
KM80ATCHTS50085M KM80ATCHTS50100M	-	-	-	-	-	5.34280R028080	90	3.54	5.34350-090100	DV50SM60070M BT50SM60090M	-	-	-	-
-	5.34032-032125	120	-	-	-	-	-	-	-	-	-	-	-	-
-	5.34050-032500 5.34050-032350 5.34050-032350	165 315 465	-	-	-	-	-	-	-	-	5.34132R032100 5.34132R032200	110 210	4.33 8.27	3.76055R032V 3.76058R032V 3.76063R032V
-	-	-	-	SSF200HTS160239 SSF200HTS160714 SSF200HTS161214 SSF200HTS161964	.39 5.14 10.14 17.64	-	-	-	-	-	-	-	-	-
KM80ATCHTS50085M KM80ATCHTS50100M	-	-	-	-	-	5.34280R032080	90	3.5	5.34350-090100	DV50SM60070M BT50SM60090M	-	-	-	-
-	5.34050-040148 5.34050-040300 5.34050-040450 5.34050-040600	140 267 417 567	-	-	-	-	-	-	-	-	-	-	-	-
-	-	-	-	SSF200HTS220297 SSF200HTS220922 SSF200HTS221572 SSF200HTS222572	.47 7.22 13.72 23.72	-	-	-	-	-	5.34140R040200	212	8.35	3.76063R040V* 3.76068R040V 3.76073R040V 3.76078R040V
KM80ATCHTS50085M KM80ATCHTS50100M	-	-	-	-	-	5.34280R040080	90	3.62	5.34350-090100	DV50SM60070M BT50SM60090M	-	-	-	-

(continued)

(HTS Tool Assembly Combinations — continued)

HTS Tool Assembly Combinations

- Select your appropriate drill diameter range.
- Choose the appropriate adaptor and shank size.
- Follow the columns to the right, and select the appropriate components from each column to complete your HTS(-R) tool.

drilling range		shank		DV		BT		CV		HSK
				assembly details		assembly details		assembly details		assembly details
mm	in		D1	40	50	40	50	40	50	50/63/100
78–84* 84–90 90–96 96–102	3.07–3.31 3.31–3.54 3.54–3.70 3.78–4.02	WD/ WN	50	–	DV50BWD50075M DV50RMWD50144M**	–	BT50BWD50085M BT50RMWD50162M**	–	CV50BWD50M343 CV50RMWD50M472**	HSK100ASWN50110M
		SS(F)	2.00	–	–	–	–	–	CV50SS200562 (AD) CV50SS200762 (AD) CV50BSSF200550	–
		HTS	50	–	5.36050–154050	–	BT50BHTS50080M	–	CV50BHTS50M314 CV50RMHTS50M413**	–
96–102* 102–108 108–115	3.78–4.02 4.02–4.25 4.25–4.53	WD/ WN	50	–	DV50BWD50075M DV50RMWD50144M**	–	BT50BWD50085M BT50RMWD50162M**	–	CV50BWD50M343 CV50RMWD50M472**	HSK100ASWN50110M
		SS(F)	2.00	–	–	–	–	–	CV50SS200562 (AD) CV50SS200762 (AD) CV50BSSF200550	–
		HTS	50	–	5.36050–154050	–	BT50BHTS50080M	–	CV50BHTS50M314 CV50RMHTS50M413**	–
115–122 122–130 130–140	4.53–4.80 4.80–5.12 5.12–5.51	SS(F)	40	–	–	–	–	–	CV50SS250800	–
		HTS	40	5.36050154040	–	BT50BHTS40080M	–	CV50BHTS40M314 CV50RMHTS40M412**	–	HSK100AHTS40085M
			50	–	5.36050–154050	–	BT50BHTS50080M	–	CV50BHTS50M314 CV50RMHTS50M413**	HSK100AHTS50090M
140–150 150–158 158–162 162–170	5.51–5.91 5.91–6.22 6.22–6.38 6.38–6.70	HTS	50	–	5.36050–154050	–	BT50BHTS50080M	–	CV50BHTS50M314 CV50RMHTS50M413**	HSK100AHTS50090M
180–186 195–201 213–220	7.08–7.32 7.68–7.91 8.39–8.66	customised solutions available upon request								
230–240 260–270	9.06–9.45 10.24–10.63	customised solutions available upon request								

* HTS drilling head with reinforced body for short-chipping materials.

** Adaptor with coolant ring.

The shown combinations are not complete. Ask your Kennametal representative to get the most reasonable solution for your application. Please note that the assembled total length of the drilling tool is not necessarily the total achievable drilling depth.

KM™	basic shank			reducer		extension		HTS head					
	assembly details	L4	L4	L1	for use with coolant adaptor		L1						
80	metric	mm	inch	in	mm	in	coolant adaptor	shell mill DV/BT	mm	in			
-	5.34050-048168 5.34050-048300 5.34050-048450 5.34050-048600	160 267 417 567	-	-	-	-	-	-	-	-			
-	-	-	SSF200HTS270297 SSF200HTS271122 SSF200HTS271922 SSF200HTS273122	1.47 9.22 17.22 29.22	-	-	-	-	5.34140R048200	212	8.35	3.76078R048V* 3.76084R048V 3.76090R048V 3.76096R048V	
KM80ATCHTS50085M KM80ATCHTS50100M	-	-	-	-	5.34280R048080	92	3.62	5.34350-090100	DV50SM60070M BT50SM60090M	-	-	-	
-	5.34050-058186 5.34050-058300 5.34050-058450 5.34050-058600	180 254 404 554	-	-	-	-	-	-	-	-	-	-	
-	-	-	SSF200HTS160239 SSF200HTS160714 SSF200HTS161214 SSF200HTS161964	.39 5.14 10.14 17.64	-	-	-	-	5.34158R058300	314	12.36	3.76096R058V* 3.76102R058V 3.76108R058V	
KM80ATCHTS50085M KM80ATCHTS50100M	-	-	-	-	5.34280R058080	94	3.70	5.34350-090100	DV50SM60070M BT50SM60090M	-	-	-	
-	-	-	SSF250HTS400355 SSF250HTS401055 SSF250HTS401555 SSF250HTS402555	1.63 8.21 13.21 23.21	-	-	-	-	-	-	-	-	
KM80ATCHTS40085M KM80ATCHTS40100M	-	-	-	-	5.34280R070150	164	6.45	5.34350-090100	DV50SM60070M BT50SM60090M	5.34170R070300 5.34170R070500	314 514	12.36 20.24	3.76115R070V 3.76122R070V 3.76130R070V
KM80ATCHTS50085M KM80ATCHTS50100M	-	-	-	-	-	-	-	-	-	-	-	-	-
KM80ATCHTS50085M KM80ATCHTS50100M	-	-	SSF300HTS500413 SSF300HTS501313 SSF300HTS502113 SSF300HTS503113	1.87 10.55 18.55 28.55	-	-	-	5.34350-090100	DV50SM60070M BT50SM60090M	5.34180R080204 5.34180R080300 5.34180R080500	220 316 516	8.66 12.44 20.32	3.76140R080V 3.76150R080V 3.76158R080V 3.76162R080V
customised solutions available upon request												3.76180R110 3.76195R110 3.76213R125	
customised solutions available upon request												3.76230R160 3.76260R160	

Adaptor

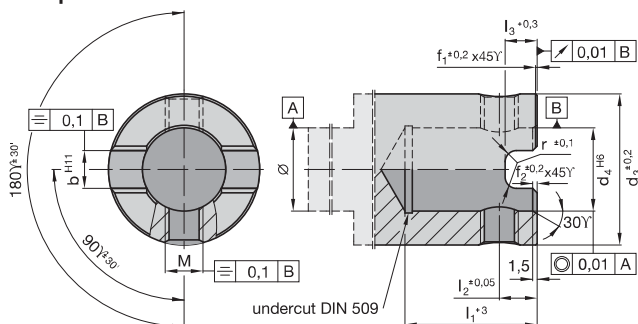

Mounting

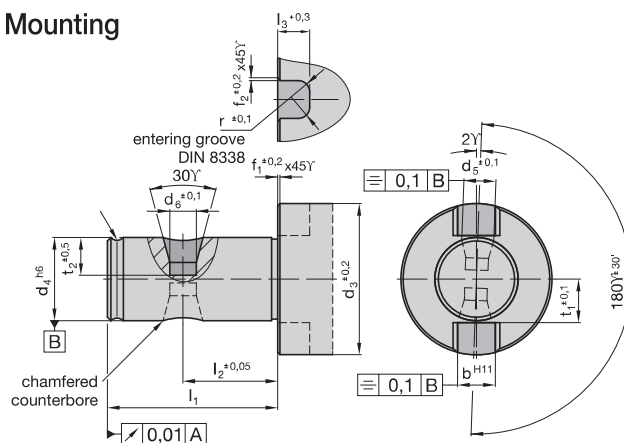

Adaptor Dimensions

d3	d4	l1	l2	l3	M	b	r	f1	f2	drive ring	clamping screw	thread	MAN* Nm	sliding block	clamping screw M 12 x 25 for sliding block
25	13	28	12,4	7,0	M8 x 1,0	8,0	3	0,5	0,5	193.371	193.372	M8 x 1,0	10	-	-
28	13	28	12,4	7,0	M8 x 1,0	8,0	3	0,5	0,5	192.419	193.372	M8 x 1,0	10	-	-
32	16	32	14,4	7,5	M8 x 1,0	8,0	3	0,5	0,5	192.420	192.156	M8 x 1,0	10	-	-
40	22	35	13,4	8,5	M10 x 1,0	10,0	3	0,5	0,5	192.421	192.157	M10 x 1,0	16	-	-
48	27	40	15,4	9,0	M12 x 1,0	12,0	3	1,0	1,0	192.422	191.727	M12 x 1,0	16	-	-
58	32	38	15,4	10,0	M12 x 1,0	14,0	3	1,0	1,0	192.423	191.727	M12 x 1,0	20	-	-
70	40	43	16,4	10,0	M16 x 1,5	16,0	3	1,0	1,0	192.424	191.728	M16 x 1,5	34	-	-
80	50	46	20,4	12,5	M16 x 1,5	18,0	4	1,0	1,0	192.425	191.728	M16 x 1,5	34	-	-
90	50	46	20,4	12,5	M16 x 1,5	18,0	4	1,0	1,0	192.426	191.729	M16 x 1,5	34	-	-
110	60	46	20,4	12,5	M16 x 1,5	20,0	4	1,0	1,0	192.427	191.729	M16 x 1,5	34	-	-
125 1)	60	77	40,0	12,5	M24 x 2,0	25,5	4	1,0	1,0	-	193.107	M24 x 2,0	120	191.019	125.225
140 1)	70	82	40,0	12,5	M24 x 2,0	25,5	4	1,0	1,0	-	193.107	M24 x 2,0	120	191.019	125.225
160 1)	80	82	40,0	12,5	M24 x 2,0	25,5	4	1,0	1,0	-	193.107	M24 x 2,0	120	191.019	125.225

* MAN = Clamping torque of clamping screw in Nm.

Mounting Dimensions

d3	d4	d5	d6	l1	l2	l3	t1	t2	b	r	f1	f2
25	13	8,50	6,5	35	22,0	7,00	6,7	6,50	8,0	3	0,5	0,5
28	13	8,50	6,5	35	22,0	7,00	7,0	6,50	8,0	3	0,5	0,5
32	16	8,30	6,5	40	24,0	7,50	8,5	7,50	8,0	3	0,5	0,5
40	22	10,50	7,0	45	25,0	8,50	11,5	10,00	10,0	3	0,5	0,5
48	27	12,75	9,0	50	27,0	9,00	14,0	12,00	12,0	3	1,0	1,0
58	32	11,50	9,0	50	29,0	10,00	16,5	7,25	14,0	3	1,0	1,0
70	40	15,25	12,2	55	30,0	10,50	20,5	10,00	16,0	3	1,0	1,0
80	50	15,25	12,2	60	36,0	12,50	25,5	12,50	18,0	4	1,0	1,0
90	50	16,50	12,2	60	36,0	12,50	25,5	12,50	18,0	4	1,0	1,0
110	60	14,50	12,2	60	36,0	13,65	30,5	10,00	20,0	4	1,0	1,0
125 1)	60	25,00	18,0	75	39,5	17,00	35,0	20,25	25,5	6	1,0	1,0
140 1)	70	25,00	18,0	80	39,5	17,00	42,0	20,25	25,5	6	1,0	1,0
160 1)	80	25,00	18,0	80	39,5	17,00	42,0	20,25	25,5	6	1,0	1,0

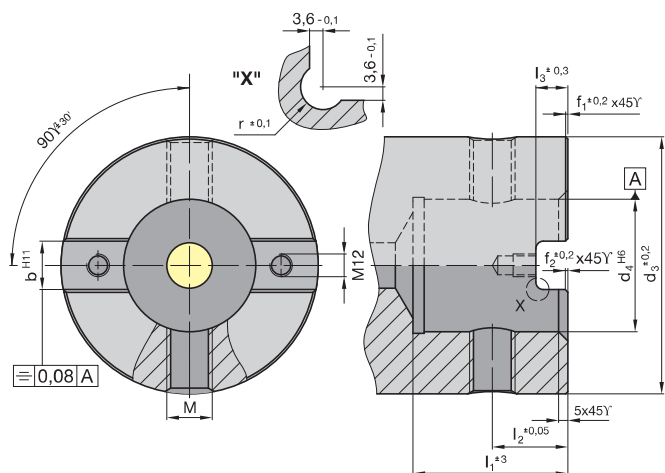

1) Adaptor for d3 = 125, 140, and 160

- Head shipped with clamping and adjusting screws.
- Order pilot drill and cartridges separately; see page J68 for pilot drill.

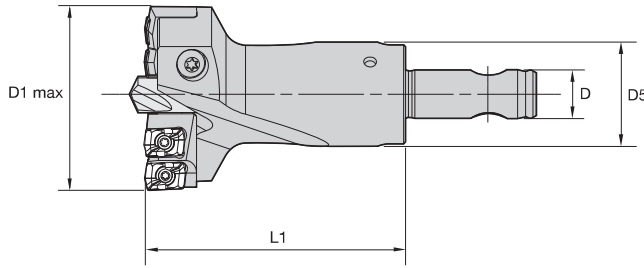

HTS Adjustable Heads with DFR™ Inserts

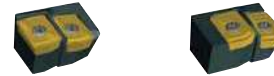

catalogue number	D1	D1 max	D5	D	L1	pilot drill		cartridge		gage insert			
						HSS	carbide	interior	n	exterior	n	insert	ni
HTSR040R025M	40	43	25	13A	60	B513S08..	B514S08..	HTSR10CI	1	HTSR10CE	1	DFR0302..	4
HTSR043R025M	43	46	25	13A	70	B513S10..	B514S10..	HTSR11CI	1	HTSR11CE	1	DFR0302..	4
HTSR046R028M	46	49	28	13B	70	B513S10..	B514S10..	HTSR12CI	1	HTSR12CE	1	DFR0403..	4
HTSR049R028M	49	52	28	13B	70	B513S10..	B514S10..	HTSR13CI	1	HTSR13CE	1	DFR0403..	4
HTSR052R028M	52	55	28	13B	70	B513S10..	B514S10..	HTSR14CI	1	HTSR14CE	1	DFR0403..	4

NOTE: n: number of cartridges required by head.
ni: number of inserts required by head.

D1 diameter			
mm	in		
40-42	1.57-1.68	190.116	128.610
43-52	1.69-2.05	193.397	190.458

HTS DFR Cartridges

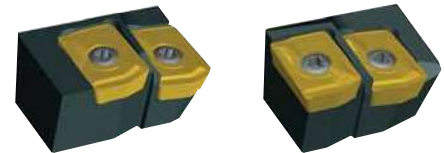

catalogue number	gage insert	Nm	ft. lbs.	insert screw	cartridge screw	washer
HTSR10CE	DFR0302..	5,0	3.69	192.416	192.592	192.902
HTSR10CI	DFR0302..	5,0	3.69	192.416	192.592	192.902
HTSR11CE	DFR0302..	5,0	3.69	192.416	192.592	192.902
HTSR11CI	DFR0302..	5,0	3.69	192.416	192.592	192.902
HTSR12CE	DFR0403..	5,0	3.69	192.432	192.592	192.902
HTSR12CI	DFR0403..	5,0	3.69	192.432	192.592	192.902
HTSR13CE	DFR0403..	5,0	3.69	192.432	192.592	192.902
HTSR13CI	DFR0403..	5,0	3.69	192.432	192.592	192.902
HTSR14CE	DFR0403..	5,0	3.69	192.432	192.592	192.902
HTSR14CI	DFR0403..	5,0	3.69	192.432	192.592	192.902

- Change drill diameter by shortening the outer cartridge.
- Shorten at 90° to the contact face A and the support face B.
- Shortening reduces the effective drill diameter by 2x the amount removed.

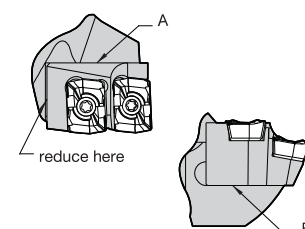

- Choose between HSS and solid carbide.

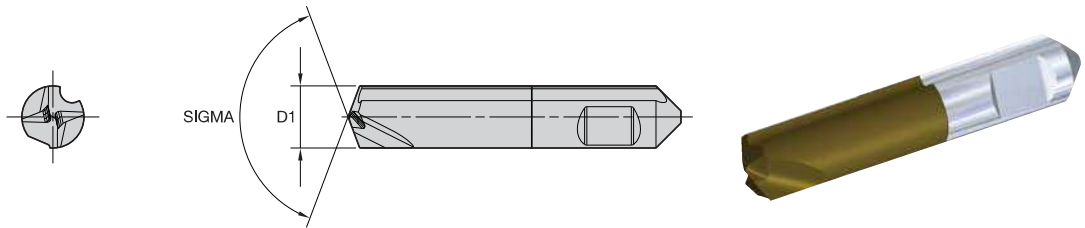

Indexable Drills

■ HTS DFR™ • Pilot Drills

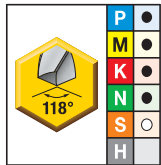

high-speed steel uncoated

A30

B513S08000 A30
B513S10000 A30

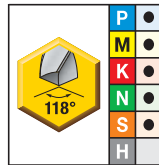

high-speed steel coated

AS3

B513S08000 AS3
B513S10000 AS3

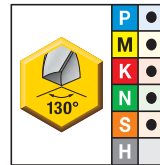

solid carbide coated

KC7030

B514S08000 KC7030
B514S10000 KC7030

- first choice
- alternate choice

A30		AS3		KC7030		D1
B513S08000 A30		B513S08000 AS3		B514S08000 KC7030		8
B513S10000 A30		B513S10000 AS3		B514S10000 KC7030		10

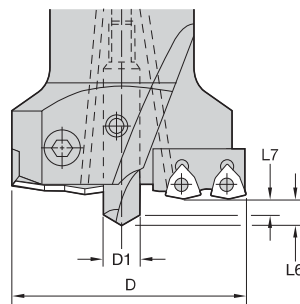

■ HTS DFR • Pilot Drills

D1		high-speed steel				solid carbide			
		L6		L7		L6		L7	
mm	in	mm	in	mm	in	mm	in	mm	in
8,00	.315	4,14	.163	1,73	.068	3,61	.142	1,73	.068
10,00	.394	4,88	.192	1,88	.074	4,19	.165	1,88	.074

HTS DFR™ • Metric

Material Group	Condition	Pocket Seat	Geometry	Grade	Metric						
					Cutting Speed – vc			Recommended Feed Rate (f) by Diameter			
					Range – m/min			Ø	DFR03... 40,00–46,00mm	DFR04 46,00–55,00mm	
min	Starting Value	max									
P	1	S	O	MD	KCU25	79	190	229	mm/r	0,10–0,14	0,12–0,18
			I	MD	KCU25						
		U	O	MD	KCU40	71	130	171	mm/r	0,10–0,14	0,12–0,18
			I	MD	KCU40						
	I	O	MD	KC7140	44	80	106	mm/r	0,10–0,14	0,12–0,18	
		I	MD	KC7140							
	2	S	O	GD	KCU25	75	180	217	mm/r	0,10–0,14	0,12–0,18
				GD	KCU25						
		U	O	GD	KCU40	71	120	271	mm/r	0,10–0,14	0,12–0,18
			I	GD	KCU40						
	I	O	GD	KC7140	44	70	106	mm/r	0,10–0,14	0,12–0,18	
		I	GD	KC7140							
	3	S	O	GD	KCU25	60	140	169	mm/r	0,10–0,14	0,12–0,18
				GD	KCU25						
		U	O	GD	KCU40	50	100	121	mm/r	0,10–0,14	0,12–0,18
			I	GD	KCU40						
	I	O	GD	KC7140	30	60	72	mm/r	0,10–0,14	0,12–0,18	
		I	GD	KC7140							
	4	S	O	GD	KCU25	79	120	229	mm/r	0,10–0,14	0,12–0,18
				GD	KCU25						
		U	O	GD	KCU40	71	100	171	mm/r	0,10–0,14	0,12–0,18
			I	GD	KCU40						
	I	O	GD	KC7140	44	80	106	mm/r	0,10–0,14	0,12–0,18	
		I	GD	KC7140							
5	S	O	GD	KCU40	62	100	190	mm/r	0,06–0,11	0,07–0,14	
			GD	KCU40							
	U	O	GD	KC7140	47	60	114	mm/r	0,06–0,11	0,07–0,14	
		I	GD	KC7140							
I	O	GD	KC7140	31	40	76	mm/r	0,06–0,11	0,07–0,14		
	I	GD	KC7140								
6	S	O	GD	KCU40	59	95	180	mm/r	0,07–0,11	0,08–0,13	
			GD	KCU40							
	U	O	GD	KC7140	45	57	108	mm/r	0,07–0,11	0,08–0,13	
		I	GD	KC7140							
I	O	GD	KC7140	30	38	72	mm/r	0,07–0,11	0,08–0,13		
	I	GD	KC7140								
M	1	S	O	MD	KCU40	40	110	134	mm/r	0,07–0,11	0,12–0,18
			I	MD	KC7140						
		U	O	MD	KC7140	31	70	86	mm/r	0,07–0,11	0,12–0,18
			I	MD	KC7140						
	2	S	O	MD	KCU40	38	99	127	mm/r	0,07–0,11	0,12–0,18
				MD	KC7140						
		U	O	MD	KC7140	31	63	86	mm/r	0,07–0,11	0,12–0,18
			I	MD	KC7140						
	3	S	O	MD	KCU40	32	88	107	mm/r	0,07–0,11	0,12–0,18
				MD	KC7140						
		U	O	MD	KC7140	31	56	86	mm/r	0,07–0,11	0,12–0,18
			I	MD	KC7140						
I	O	MD	KC7140	22	40	61	mm/r	0,07–0,11	0,12–0,18		
	I	MD	KC7140								

Condition: S = Stable cutting conditions;
 U = Unstable cutting conditions;
 I = Interrupted cutting conditions

Pocket seat: I = Inboard insert;
 O = Outboard insert



■ HTS DFR™ • Metric

Indexable Drills

Material Group	Condition	Pocket Seat	Geometry	Grade	Metric						
					Cutting Speed – vc			Recommended Feed Rate (f) by Diameter			
					Range – m/min			Ø	DFR03... 40,00–46,00mm	DFR04... 46,00–55,00mm	
min	Starting Value	max									
K	1	O	GD	KCPK10	79	171	229	mm/r	0,11–0,20	0,13–0,27	
			GD	KCPK10							
		I	LD	KCU25	64	117	156				
			LD	KCU25							
		O	LD	KCU40	40	72	96				
			LD	KCU40							
	2	S	O	GD	KCPK10	75	162	217			
				GD	KCPK10						
		U	O	GD	KCU25	64	111	156			
				GD	KCU25						
		I	O	LD	KCU40	40	68	96			
				LD	KCU40						
3	S	O	GD	KCPK10	68	146	195				
			GD	KCPK10							
	U	O	GD	KCU25	59	100	144				
			GD	KCU25							
	I	O	GD	KCU40	35	62	84				
			GD	KCU40							
N	1	S	ST	KD1425	128	240	358	mm/r	0,06–0,09	0,11–0,19	
			ST	KD1425							
		U	O	LD	KCU40	102	160				239
				LD	KCU40						
		I	O	LD	KCU40	67	104				155
				LD	KCU40						
	2	S	O	ST	KD1425	119	223	333			
				ST	KD1425						
		U	O	LD	KCU40	102	149	239			
				LD	KCU40						
		I	O	LD	KCU40	67	97	155			
				LD	KCU40						
	3	S	O	ST	KD1425	110	206	308			
				ST	KD1425						
		U	O	LD	KCU40	102	138	239			
				LD	KCU40						
		I	O	LD	KCU40	67	89	155			
				LD	KCU40						
	4	S	O	ST	KD1425	119	223	333			
				ST	KD1425						
		U	O	LD	KCU40	102	149	239			
				LD	KCU40						
		I	O	LD	KCU40	67	97	155			
				LD	KCU40						
5	S	O	ST	KD1425	92	220	262				
			ST	KD1425							
	U	O	LD	KCU40	72	140	167				
			LD	KCU40							
	I	O	LD	KCU40	46	90	107				
			LD	KCU40							

Condition: S = Stable cutting conditions;
 U = Unstable cutting conditions;
 I = Interrupted cutting conditions

Pocket seat: I = Inboard insert;
 O = Outboard insert

Difficult Applications Made Easy

Use DS and LP geometries to avoid bird nesting and long, stringy chips in low-carbon steel applications.

- The new DS insert style can be used on Drill Fix™ DFT™, HTS, and KSEM PLUS™ tooling systems.
- LP-style inserts can be used on Drill Fix DFSP™ as outboard inserts.
- Use the new geometries in all applications where long chips are an issue.

See pages J4–J50 for Drill Fix indexable drills.

See pages H80–H82 and H84–H101, and H106 for KSEM PLUS A1 and B1 head systems.



Experience the advantages at your Authorised Kennametal Distributor or at kennametal.com.

- Head shipped with clamping and adjusting screws.
- Order pilot drill separately; see page J76.
- Order cartridges separately; see pages J74.

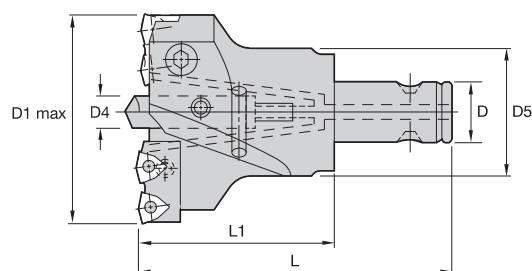

■ HTS Adjustable Heads • DFT™ inserts

Indexable Drills

catalogue number	D1	D1 max	D5	D	L	L1	kg	pilot drill	cartridge interior		cartridge exterior		gage insert	
									n	n	n	ni		
3.76045R028V	45	50	28	13	85	50	0.3	B510S08.	3.77000R050V	1	3.77000R051V	1	DFT0303.	4
3.76050R028V	50	55	28	13	85	50	0.4	B510S08.	3.77000R052V	1	3.77000R053V	1	DFT0303.	4
3.76055R032V	55	58	33	16	100	60	0.4	B510S08.	3.77000R038V	1	3.77000R039V	1	DFT05T3.	4
3.76058R032V	58	63	33	16	100	60	0.4	B510S10.	3.77000R023V	1	3.77000R024V	1	DFT05T3.	4
3.76063R032V	63	68	33	16	100	60	0.4	B510S10.	3.77000R025V	1	3.77000R024V	1	DFT05T3.	4
3.76063R040V	63	68	41	22	115	70	0.5	B510S10.	3.77000R025V	1	3.77000R024V	1	DFT05T3.	4
3.76068R040V	68	73	41	22	115	70	0.8	B510S10.	3.77000R026V	1	3.77000R027V	1	DFT05T3.	4
3.76073R040V	73	78	41	22	115	70	0.8	B510S15.	3.77000R026V	1	3.77000R027V	1	DFT05T3.	4
3.76078R040V	78	84	41	22	115	70	0.8	B510S15.	3.77000R028V	1	3.77000R029V	1	DFT06T3.	4
3.76078R048V	78	84	49	27	120	70	0.9	B510S15.	3.77000R028V	1	3.77000R029V	1	DFT06T3.	4
3.76084R048V	84	90	49	27	120	70	1.0	B510S15.	3.77000R028V	1	3.77000R029V	1	DFT06T3.	4
3.76090R048V	90	96	49	27	120	70	1.0	B510S15.	3.77000R030V	1	3.77000R031V	1	DFT06T3.	4
3.76096R048V	96	102	49	27	120	70	1.1	B510S20.	3.77000R030V	1	3.77000R031V	1	DFT06T3.	4
3.76096R058V	96	102	59	32	130	80	1.2	B510S20.	3.77000R030V	1	3.77000R031V	1	DFT06T3.	4
3.76102R058V	102	108	59	32	130	80	1.7	B510S20.	3.77000R081V	1	3.77000R082V	1	DFT05T3.	6
3.76108R058V	108	115	59	32	130	80	1.8	B510S20.	3.77000R083V	1	3.77000R084V	1	DFT06T3.	6
3.76115R070V	115	122	71	40	145	90	2.9	B510S20.	3.77000R085V	1	3.77000R086V	1	DFT06T3.	6
3.76122R070V	122	130	71	40	145	90	2.9	B510S25.	3.77000R079V	1	3.77000R080V	1	DFT06T3.	6
3.76130R070V	130	140	71	40	145	90	3.0	B510S25.	3.77000R087V	1	3.77000R088V	1	DFT06T3.	6
3.76140R080V	140	150	81	50	160	100	4.3	B510S25.	3.77000R077V	1	3.77000R078V	1	DFT0704.	6
3.76150R080V	150	158	81	50	160	100	4.5	B510S25.	3.77000R075V	1	3.77000R076V	1	DFT0704.	6
3.76158R080V	158	162	81	50	160	100	4.5	B510S25.	3.77000R073V	1	3.77000R074V	1	DFT0704.	6
3.76162R080V	162	170	80	50	160	100	4.5	B510S30.	3.77000R048V	1	3.77000R049V	1	DFT0704.	6
3.76180R110	180	186	110	60	185	125	6.0	B510S30.	3.77000R030V	3	3.77000R031V	1	DFT06T3.	8
3.76195R110	195	201	110	60	185	125	6.5	B510S30.	3.77000R081V	3	3.77000R082V	1	DFT05T3.	12
3.76213R125	213	220	125	60	200	125	7.5	B510S30.	3.77000R083V	3	3.77000R084V	1	DFT06T3.	12
3.76230R160	230	240	160	80	230	150	8.5	B510S30.	3.77000R079V	2	3.77000R080V	2	DFT06T3.	12
3.76260R160 *	260	270	160	80	230	150	9.0	B510S30.	3.77000R077V	2	3.77000R078V	2	DFT06T3.	12

NOTE: *Made-to-order standard item. Standard pricing, manufacturing lead time, and minimum order quantity applies.
n: number of cartridges required by head.
ni: number of inserts required by head.



- Head shipped with clamping and adjusting screws.
- Order pilot drill separately; see page J76.
- Order cartridges separately; see pages J74–J75.

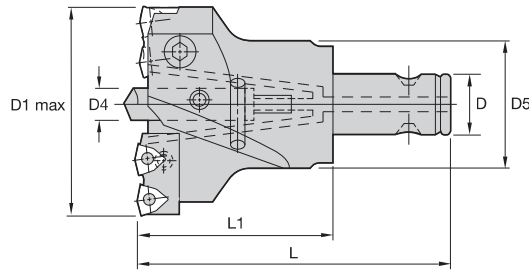

HTS Adjustable Heads • DFT™ and SPHX Inserts

catalogue number	D1	D1 max	pilot drill	cartridge interior		cartridge interior 2		insert		cartridge exterior SPHX		gage insert	
				n		n		n	ni	n	ni		
3.76045R028V	45	50	B510S08.	3.77000R250V	1	—	—	DFT0303.	3	3.77000R251V	1	SPHX0703.	1
3.76050R028V	50	55	B510S08.	3.77000R252V	1	—	—	DFT0303.	3	3.77000R253V	1	SPHX0703.	1
3.76055R032V	55	58	B510S08.	3.77000R038V	1	—	—	DFT05T3.	3	3.77000R239V	1	SPHX0903.	1
3.76058R032V	58	63	B510S10.	3.77000R023V	1	—	—	DFT05T3.	3	3.77000R224V	1	SPHX0903.	1
3.76063R032V	63	68	B510S10.	3.77000R025V	1	—	—	DFT05T3.	3	3.77000R224V	1	SPHX0903.	1
3.76063R040V	63	68	B510S10.	3.77000R025V	1	—	—	DFT05T3.	3	3.77000R224V	1	SPHX0903.	1
3.76068R040V	68	73	B510S10.	3.77000R026V	1	—	—	DFT05T3.	3	3.77000R227V	1	SPHX0903.	1
3.76073R040V	73	78	B510S15.	3.77000R026V	1	—	—	DFT05T3.	3	3.77000R227V	1	SPHX0903.	1
3.76078R040V	78	84	B510S15.	3.77000R028V	1	—	—	DFT06T3.	3	3.77000R229V	1	SPHX0903.	1
3.76078R048V	78	84	B510S15.	3.77000R028V	1	—	—	DFT06T3.	3	3.77000R229V	1	SPHX0903.	1
3.76084R048V	84	90	B510S15.	3.77000R228V	1	—	—	DFT06T3.	3	3.77000R229V	1	SPHX0903.	1
3.76090R048V	90	96	B510S15.	3.77000R230V	1	—	—	DFT06T3.	3	3.77000R231V	1	SPHX0903.	1
3.76096R048V	96	102	B510S20.	3.77000R230V	1	—	—	DFT06T3.	3	3.77000R231V	1	SPHX0903.	1
3.76096R058V	96	102	B510S20.	3.77000R230V	1	—	—	DFT06T3.	3	3.77000R231V	1	SPHX0903.	1
3.76102R058V	102	108	B510S20.	3.77000R081V	1	—	—	DFT05T3.	5	3.77000R282V	1	SPHX0903.	1
3.76108R058V	108	115	B510S20.	3.77000R083V	1	—	—	DFT06T3.	5	3.77000R284V	1	SPHX1204.	1
3.76115R070V	115	122	B510S20.	3.77000R085V	1	—	—	DFT06T3.	5	3.77000R286V	1	SPHX1204.	1
3.76122R070V	122	130	B510S25.	3.77000R079V	1	—	—	DFT06T3.	5	3.77000R280V	1	SPHX1204.	1
3.76130R070V	130	140	B510S25.	3.77000R087V	1	—	—	DFT06T3.	5	3.77000R288V	1	SPHX1204.	1
3.76140R080V	140	150	B510S25.	3.77000R077V	1	—	—	DFT0704.	5	3.77000R278V	1	SPHX1505.	1
3.76150R080V	150	158	B510S25.	3.77000R075V	1	—	—	DFT0704.	5	3.77000R276V	1	SPHX1204.	1
3.76158R080V	158	162	B510S25.	3.77000R073V	1	—	—	DFT0704.	5	3.77000R274V	1	SPHX1204.	1
3.76162R080V	162	170	B510S30.	3.77000R248V	1	—	—	DFT0704.	5	3.77000R249V	1	SPHX1505.	1
3.76180R110	180	186	B510S30.	3.77000R230V	3	—	—	DFT06T3.	7	3.77000R231V	1	SPHX0903.	1
3.76195R110	195	201	B510S30.	3.77000R081V	3	—	—	DFT05T3.	11	3.77000R282V	1	SPHX0903.	1
3.76213R125	213	220	B510S30.	3.77000R083V	3	—	—	DFT06T3.	11	3.77000R284V	1	SPHX1204.	1
3.76230R160	230	240	B510S30.	3.77000R079V	2	3.77000R080V	1	DFT06T3.	11	3.77000R280V	1	SPHX1204.	1
3.76260R160 *	260	270	B510S30.	—	2	—	—	DFT06T3.	11	3.77000R078V	1	SPHX1204.	1

NOTE: *Made-to-order standard item. Standard pricing, manufacturing lead time, and minimum order quantity applies.
 n: number of cartridges required by head.
 ni: number of inserts required by head.

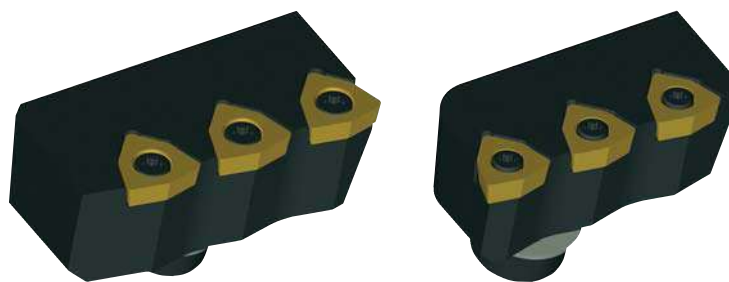

■ HTS Interior and Exterior Cartridges • DFT™ Inserts

Indexable Drills

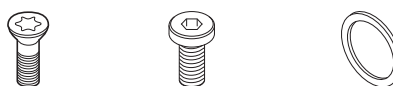

catalogue number	gage insert	number of inserts	insert screw	cartridge screw	fan washer	Nm	ft. lbs.
3.77000R023V	DFT05T3..	2	191.924	192.593	192.903	5,0	3.69
3.77000R024V	DFT05T3..	2	191.924	192.593	192.903	5,0	3.69
3.77000R025V	DFT05T3..	2	191.924	192.593	192.903	5,0	3.69
3.77000R026V	DFT05T3..	2	191.924	192.593	192.903	5,0	3.69
3.77000R027V	DFT05T3..	2	191.924	192.593	192.903	5,0	3.69
3.77000R028V	DFT06T3..	2	191.848	129.612	192.111	10,0	7.38
3.77000R029V	DFT06T3..	2	191.848	129.612	192.111	10,0	7.38
3.77000R030V	DFT06T3..	2	191.848	129.616	192.111	10,0	7.38
3.77000R031V	DFT06T3..	2	191.848	129.616	192.111	10,0	7.38
3.77000R038V	DFT05T3..	2	191.924	192.593	192.903	5,0	3.69
3.77000R039V	DFT05T3..	2	191.924	192.593	192.903	5,0	3.69
3.77000R048V	DFT0704..	3	191.698	125.830	192.112	35,0	25.81
3.77000R049V	DFT0704..	3	191.698	125.830	192.112	35,0	25.81
3.77000R050V	DFT0303..	2	192.432	192.592	192.902	5,0	3.69
3.77000R051V	DFT0303..	2	192.432	192.592	192.902	5,0	3.69
3.77000R052V	DFT0303..	2	192.432	192.592	192.902	5,0	3.69
3.77000R053V	DFT0303..	2	192.432	192.592	192.902	5,0	3.69
3.77000R073V	DFT0704..	3	191.698	—	192.112	35,0	25.81
3.77000R074V	DFT0704..	3	191.698	—	192.112	35,0	25.81
3.77000R075V	DFT0704..	3	191.698	—	192.112	35,0	25.81
3.77000R076V	DFT0704..	3	191.698	—	192.112	35,0	25.81
3.77000R077V	DFT0704..	3	191.698	—	192.112	35,0	25.81
3.77000R078V	DFT0704..	3	191.698	—	192.112	35,0	25.81
3.77000R079V	DFT06T3..	3	191.848	125.820	192.112	35,0	25.81
3.77000R080V	DFT06T3..	3	191.848	125.820	192.112	35,0	25.81
3.77000R081V	DFT05T3..	3	191.924	125.820	192.112	35,0	25.81
3.77000R082V	DFT05T3..	3	191.924	125.820	192.112	35,0	25.81
3.77000R083V	DFT06T3..	3	191.848	125.820	192.112	35,0	25.81
3.77000R084V	DFT06T3..	3	191.848	125.820	192.112	35,0	25.81
3.77000R085V	DFT06T3..	3	191.848	—	192.112	35,0	25.81
3.77000R086V	DFT06T3..	3	191.848	125.820	192.112	35,0	25.81
3.77000R087V	DFT06T3..	3	191.848	125.820	192.112	35,0	25.81
3.77000R088V	DFT06T3..	3	191.848	125.820	192.112	35,0	25.81

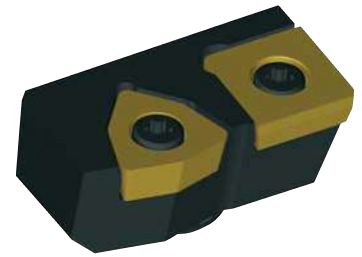

■ HTS Finishing Interior Cartridges • For Use with Exterior Cartridges Equipped with SPHX Inserts



catalogue number	gage insert	number of inserts	insert screw	washer	Nm	ft. lbs.
3.77000R228V	DFT06T3..	2	191.848	192.111	10,0	7.38
3.77000R230V	DFT06T3..	2	191.848	192.111	10,0	7.38
3.77000R248V	DFT0704..	3	191.698	192.112	35,0	25.81
3.77000R250V	DFT0303..	2	192.432	192.902	5,0	3.69
3.77000R252V	DFT0303..	2	192.432	192.902	5,0	3.69

NOTE: Modified interior cartridges for use with SPHX-equipped exterior cartridges only.

■ HTS Finishing Exterior Cartridges • SPHX Inserts

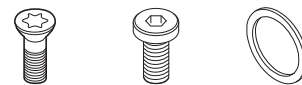

catalogue number	gage insert inside	number of inserts	gage insert outside	number of inserts	insert screw	screw	washer	Nm	ft. lbs.
3.77000R224V	DFT05T3..	2	SPHX0903..	1	191.924	193.451	192.903	5,0	3.69
3.77000R227V	DFT05T3..	2	SPHX0903..	1	191.924	192.593	192.903	5,0	3.69
3.77000R229V	DFT06T3..	2	SPHX0903..	1	191.916	129.612	192.111	10,0	7.38
3.77000R231V	DFT06T3..	2	SPHX0903..	1	191.916	129.616	192.111	10,0	7.38
3.77000R239V	DFT05T3..	2	SPHX0903..	1	191.924	193.451	192.903	5,0	3.69
3.77000R249V	DFT0704..	3	SPHX1505..	1	191.698	125.830	192.112	35,0	25.81
3.77000R251V	DFT0303..	2	SPHX0703..	1	192.432	193.450	192.902	5,0	3.69
3.77000R253V	DFT0303..	2	SPHX0703..	1	192.432	193.450	192.902	5,0	3.69
3.77000R274V	DFT0704..	3	SPHX1505..	1	191.698	—	192.112	35,0	25.81
3.77000R276V	DFT0704..	3	SPHX1505..	1	191.698	—	192.112	35,0	25.81
3.77000R278V	DFT0704..	3	SPHX1505..	1	191.698	—	192.112	35,0	25.81
3.77000R280V	DFT06T3..	3	SPHX1204..	1	191.916	125.820	192.112	35,0	25.81
3.77000R282V	DFT05T3..	3	SPHX0903..	1	191.924	125.820	192.112	35,0	25.81
3.77000R284V	DFT06T3..	3	SPHX1204..	1	191.916	125.820	192.112	35,0	25.81
3.77000R286V	DFT06T3..	3	SPHX1204..	1	191.916	—	192.112	35,0	25.81
3.77000R288V	DFT06T3..	3	SPHX1204..	1	191.916	125.820	192.112	35,0	25.81

- Change drill diameter by shortening the outer cartridge.
- Shorten at 90° to the contact face A and the support face B.
- Shortening reduces the effective drill diameter by two times the amount removed.

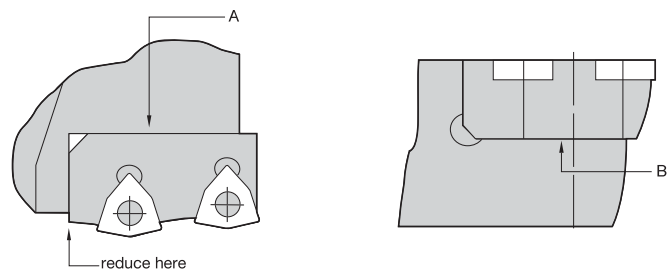

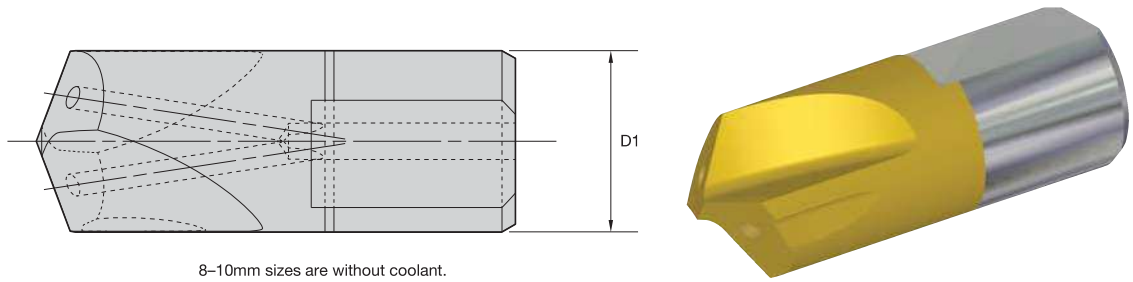

8–10mm sizes are without coolant.



■ HTS DFT™ • Pilot Drills

Indexable Drills

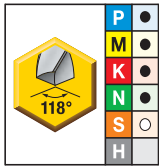

high-speed steel uncoated

A30

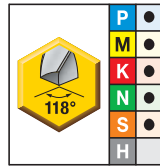

high-speed steel coated

AS3



carbide drills

KC7315

- first choice
- alternate choice

A30		AS3		KC7315		D1
B510S08000 A30		B510S08000 AS3		B511S08000 KC7315		8,00
B510S10000 A30		B510S10000 AS3		B511S10000 KC7315		10,00
B510S15000 A30		B510S15000 AS3		B511S15000 KC7315		15,00
B510S20000 A30		B510S20000 AS3		B511S20000 KC7315		20,00
B510S25000 A30		B510S25000 AS3		B511S25000 KC7315		25,00
B510S30000 A30		B510S30000 AS3		B511S30000 KC7315		30,00

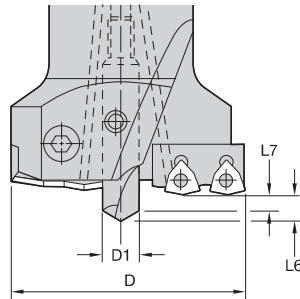

■ Pilot Drill Setting Lengths

D1		2–4 x D				4–6 x D				>6 x D			
		L6		L7		L6		L7		L6		L7	
mm	in	mm	in	mm	in	mm	in	mm	in	mm	in	mm	in
8,00	.315	3,00	.118	0,80	.032	3,40	.134	1,20	.047	3,80	.150	1,60	.063
10,00	.394	4,00	.158	1,30	.051	4,30	.169	1,60	.063	4,60	.181	1,90	.075
15,00	.591	6,20	.244	2,10	.083	6,50	.256	2,40	.095	6,80	.268	2,70	.106
20,00	.787	8,10	.319	2,60	.102	8,40	.331	2,90	.114	8,70	.343	3,20	.126
25,00	.984	10,50	.413	3,50	.138	7,40	.429	3,90	.154	11,30	.445	4,30	.169
30,00	1181	12,30	.484	4,10	.158	12,80	.504	4,50	.177	13,20	.520	5,00	.197

- Reducers are shipped with drive ring and clamping screws.

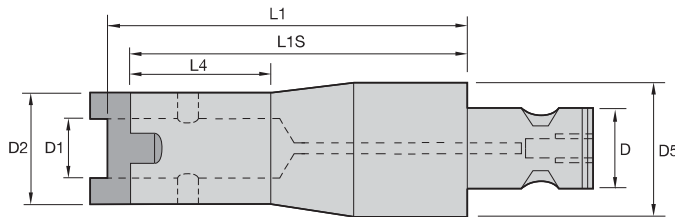

Reducers

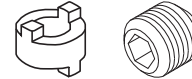

catalogue number	D1 coupling size	D coupling size	D2	D5	L1	L1S	L4	drive ring	clamping screw	Nm	ft. lbs.
5.34280R028080	13B	50	27,6	80,0	90,0	80,0	50,0	192.419	192.156	10,2	7.5
5.34280R032080	16	50	31,6	80,0	90,0	80,0	55,0	192.420	192.156	10,2	7.5
5.34280R040080	22	50	39,6	80,0	92,0	80,0	57,0	192.421	192.157	16,3	12.0
5.34280R048080	27	50	47,6	80,0	92,0	80,0	57,0	192.422	191.727	20,3	15.0
5.34280R058080	32	50	57,6	80,0	93,9	80,0	58,9	192.423	191.727	20,3	15.0
5.34240R032100	16	22	31,6	40,0	110,0	100,0	55,0	192.420	192.156	10,2	7.5
5.34248R040100	22	27	39,6	48,0	112,0	100,0	57,0	192.421	192.157	16,3	12.0
5.34258R048100	27	32	47,6	58,0	112,0	100,0	57,0	192.422	191.727	20,3	15.0
5.34270R058100	32	40	57,6	70,0	113,9	100,0	58,9	192.423	191.727	20,3	15.0
5.34280R070150	40	50	69,6	80,0	163,9	150,0	68,9	192.424	191.728	33,9	25.0

NOTE: Assemble components using recommended torque values.

- Extensions are shipped with drive ring and clamping screws.

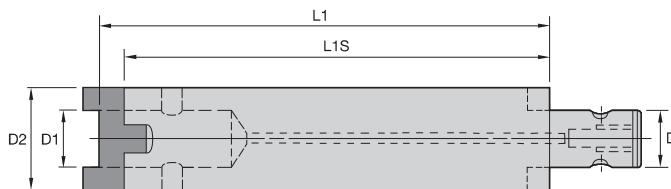

Extensions

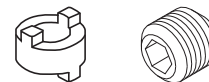

catalogue number	D1 coupling size	D coupling size	D2	L1	L1S	drive ring	clamping screw	Nm	ft. lbs.
5.34132R032100	16	16	32,0	110,0	100,0	192.420	192.156	10,2	7.5
5.34125R025150	13A	13A	25,0	160,0	150,0	193.371	193.372	10,2	7.5
5.34128R028150	13B	13B	28,0	160,0	150,0	192.419	192.156	10,2	7.5
5.34170R070186	40	40	70,0	200,0	186,0	192.424	191.728	33,9	25.0
5.34132R032200	16	16	32,0	210,0	200,0	192.420	192.156	10,2	7.5
5.34140R040200	22	22	40,0	212,0	200,0	192.421	192.157	16,3	12.0
5.34148R048200	27	27	48,0	212,0	200,0	192.422	191.727	20,3	15.0
5.34180R080204	50	50	80,0	220,0	204,0	192.425	191.728	33,9	25.0
5.34158R058300	32	32	58,0	314,0	300,0	192.423	191.727	33,9	25.0
5.34170R070300	40	40	70,0	314,0	300,0	192.424	191.728	33,9	25.0
5.34180R080300	50	50	80,0	316,0	300,0	192.425	191.728	33,9	25.0
5.34170R070500	40	40	70,0	514,0	500,0	192.424	191.728	33,9	25.0
5.34180R080500	50	50	80,0	516,0	500,0	192.425	191.728	33,9	25.0

NOTE: Assemble components using recommended torque values.

- Shanks are shipped with drive ring and clamping screws.

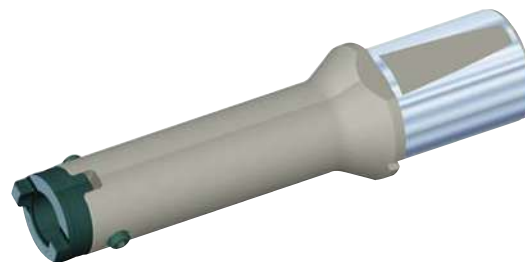
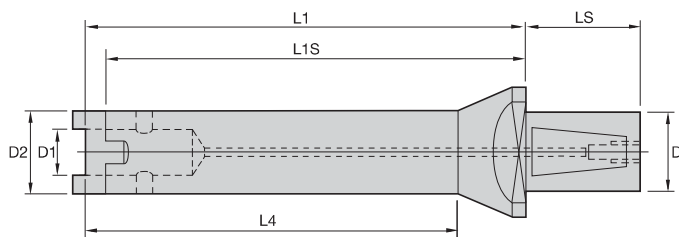

■ Basic Shank WN/WD • Metric

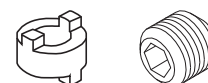

catalogue number	D1 coupling size	D	D2	L1	L1S	L4	LS	drive ring	clamping screw	Nm
5.34032-025115	13A	32,0	25,0	125,0	115,0	110,0	58,0	193.371	193.372	10,2
5.34032-028115	13B	32,0	28,0	125,0	115,0	110,0	58,0	192.419	192.156	10,2
5.34032-032125	16	32,0	32,0	135,0	125,0	120,0	58,0	192.420	192.156	10,2
5.34050-040148	22	50,0	40,0	160,0	148,0	140,0	68,0	192.421	192.157	16,3
5.34050-048168	27	50,0	48,0	175,0	168,0	160,0	68,0	192.422	191.727	20,3
5.34050-058186	32	50,0	58,0	200,0	186,0	180,0	68,0	192.423	191.727	20,3
5.34032-025200	13A	32,0	25,0	210,0	200,0	195,0	58,0	193.371	193.372	10,2
5.34032-028200	13B	32,0	28,0	210,0	200,0	195,0	58,0	192.419	192.156	10,2
5.34050-032200	16	50,0	32,0	210,0	200,0	165,0	68,0	192.420	192.156	10,2
5.34050-025300	13A	50,0	25,0	310,0	300,0	270,0	68,0	193.371	193.372	10,2
5.34050-028300	13B	50,0	28,0	310,0	300,0	265,0	68,0	192.419	192.156	10,2
5.34050-040300	22	50,0	40,0	312,0	300,0	267,0	68,0	192.421	192.157	10,2
5.34050-048300	27	50,0	48,0	312,0	300,0	267,0	68,0	192.422	191.727	16,3
5.34050-058300	32	50,0	58,0	314,0	300,0	254,0	68,0	192.423	191.727	20,3
5.34050-032350	16	50,0	32,0	360,0	350,0	315,0	68,0	192.420	192.156	10,2
5.34050-025450	13A	50,0	25,0	460,0	450,0	420,0	68,0	193.371	193.372	10,2
5.34050-028450	13B	50,0	28,0	460,0	450,0	415,0	68,0	192.419	192.156	10,2
5.34050-040450	22	50,0	40,0	462,0	450,0	417,0	68,0	192.421	192.157	10,2
5.34050-048450	27	50,0	48,0	462,0	450,0	417,0	68,0	192.422	191.727	16,3
5.34050-058450	32	50,0	58,0	464,0	450,0	404,0	68,0	192.423	191.727	20,3
5.34050-032500	16	50,0	32,0	510,0	500,0	465,0	68,0	192.420	192.156	10,2
5.34050-040600	22	50,0	40,0	612,0	600,0	567,0	68,0	192.422	192.157	10,2
5.34050-048600	27	50,0	48,0	612,0	600,0	567,0	68,0	192.422	191.727	16,3
5.34050-058600	32	50,0	58,0	614,0	600,0	554,0	68,0	192.423	191.727	20,3

NOTE: Assemble components using recommended torque values.

- Shanks are shipped with drive ring and clamping screws.

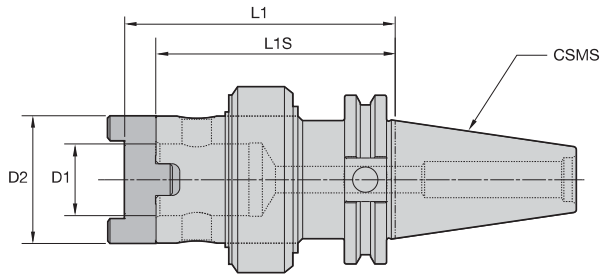

CV Taper Shank • Form AD • Rotary Coolant Ring

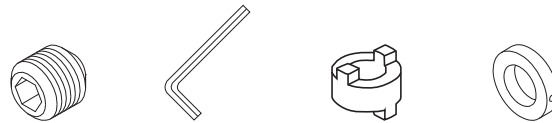

catalogue number	CSMS system size	D1 coupling size	clamping screw	hex wrench	drive ring	coolant ring	ft. lbs.
CV50RMHTS13M394	CV50	13B	192.156	170.004	192.419	302.011	7.5
CV50RMHTS16M394	CV50	16	192.156	170.004	192.420	302.011	7.5
CV50RMHTS22M394	CV50	22	192.157	170.004	192.421	302.011	12.0
CV50RMHTS27M394	CV50	27	191.727	170.006	192.422	302.011	15.0
CV50RMHTS32M394 *	CV50	32	191.727	170.006	192.423	302.011	15.0
CV50RMHTS40M413	CV50	40	191.728	170.008	192.424	302.009	26.0
CV50RMHTS50M413	CV50	50	191.728	170.008	192.425	302.010	26.0

NOTE: Assemble components using recommended torque values.

*Made-to-order standard item. Standard pricing, manufacturing lead time, and minimum order quantity applies.

- Shanks are shipped with drive ring and clamping screws.

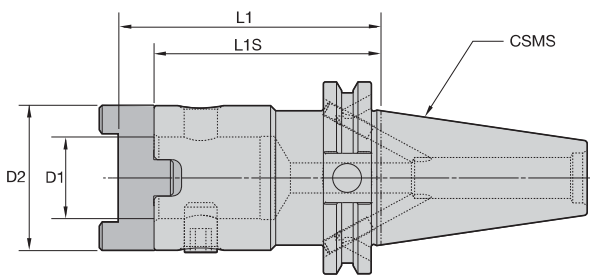

CV Taper Shank • Form B/AD Coolant

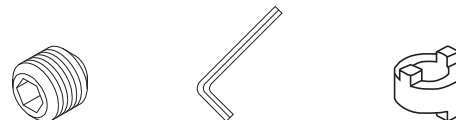

catalogue number	CSMS system size	D1 coupling size	clamping screw	hex wrench	drive ring	ft. lbs.
CV50BHTS13M295	CV50	13B	192.156	170.004	192.419	7.5
CV50BHTS16M295	CV50	16	192.156	170.004	192.420	7.5
CV50BHTS22M295	CV50	22	192.157	170.004	192.421	12.0
CV50BHTS27M295	CV50	27	191.727	170.006	192.422	15.0
CV50BHTS32M314	CV50	32	191.727	170.006	192.423	15.0
CV50BHTS40M314	CV50	40	191.728	170.008	192.424	26.0
CV50BHTS50M314	CV50	50	191.728	170.008	192.425	26.0

NOTE: Assemble components using recommended torque values.

- Shanks are shipped with drive ring and clamping screw.

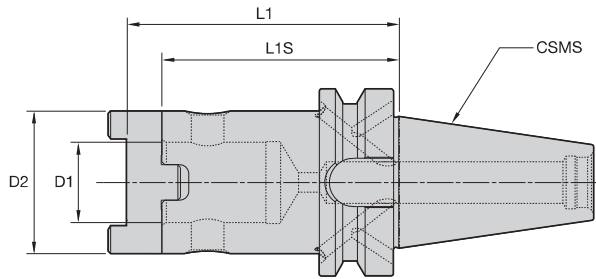

BT Taper Shank • Form B/AD Coolant

Indexable Drills

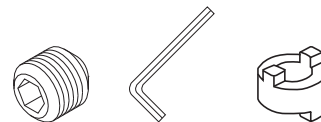

catalogue number	CSMS system size	D1 coupling size	D2	L1	L1S	clamping screw	hex wrench	drive ring	Nm	ft. lbs.
BT50BHTS22075M	BT50	22	40,0	87,0	75,0	192.157	170.005	192.421	16,0	12,0
BT50BHTS32080M	BT50	32	58,0	94,0	80,0	MS1276	170.006	192.423	20,0	15,0
BT50BHTS40080M	BT50	40	70,0	94,0	80,0	191.728	170.008	192.424	34,0	26,0
BT50BHTS50080M	BT50	50	80,0	96,0	80,0	191.728	170.008	192.425	34,0	26,0

NOTE: Assemble components using recommended torque values.

- Shanks are shipped with drive ring and clamping screw.

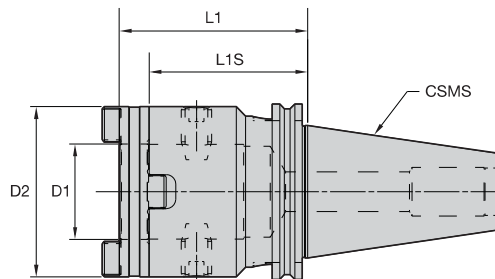

DV Taper Shank • Form B/AD Coolant

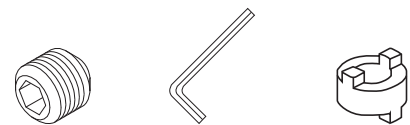

catalogue number	CSMS system size	D1 coupling size	D2	L1	L1S	clamping screw	hex wrench	drive ring
5.36050-154040	DV50	40	70,0	100,0	84,0	191.728	170.008	192.424
5.36050-154050	DV50	50	90,0	100,0	84,0	191.729	170.008	192.426

NOTE: Assemble components using recommended torque values.

		40	(2x) MS2221S	2,5mm			
		50	(2x) MS1296S	3mm			

- Shanks are shipped with drive ring and clamping screw.

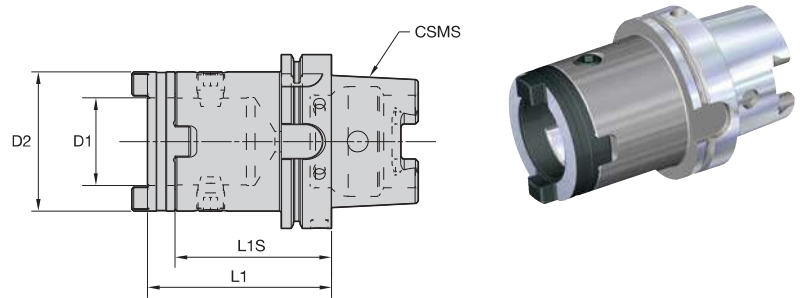

■ **HSK100A Taper Shank**

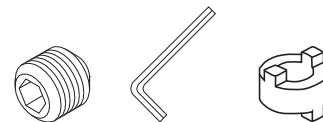

catalogue number	CSMS system size	D1 coupling size	D2	L1	L1S	clamping screw	hex wrench	drive ring	Nm	ft. lbs.
HSK100AHTS40085M	HSK100A	40	70,0	99,0	85,0	191.728	170.008	192.424	35,0	25,0
HSK100AHTS50090M	HSK100A	50	80,0	106,0	90,0	191.728	170.008	192.425	35,0	25,0

NOTE: Assemble components using recommended torque values.

- Shanks are shipped with drive ring and clamping screws.

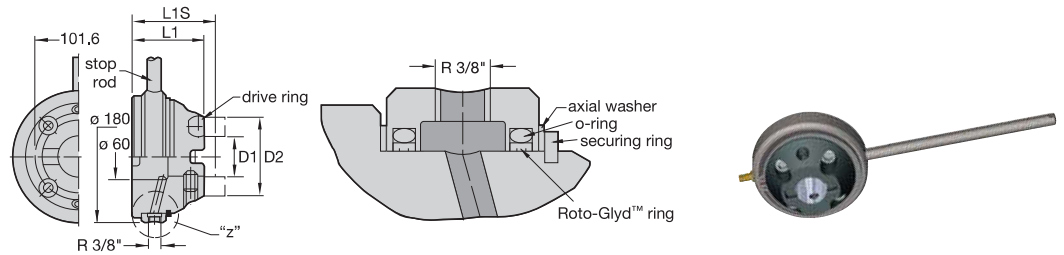

■ **Flanged Adaptor (Including Drive Ring)**

catalogue number	D1
5.34350-090100	50,00

NOTE: Adaptor includes all items shown except the nipple. Nipple must be ordered separately.
If replacement becomes necessary, the nipple is manufactured with a predetermined breaking point for safety purposes.
Maximum RPM is 1500. Maximum pressure is 72 psi or 5 bar.

■ **Spare Parts**



drive ring	clamping screw	coolant ring	O-ring	securing ring	axial washer	ROTO-GLYD ring	stop bar	nipple
192.426	191.729	302.014	192.731	192.126	192.158	192.730	460.716	192.759

■ HTS DFT™ • Metric



					Metric							
Material Group	Condition	Pocket Seat	Geometry	Grade	Cutting Speed – vc			Recommended Feed Rate (f) by Diameter				
					Range – m/min			Ø	DFT03... 45,00–55,00mm	DFT05... 55,00–78,00mm	DFT06... 78,00–140,00mm	DFT07... 140,00–270,00mm
					min	Starting Value	max					
P	1	S	O MD	KCU25	94	190	229	mm/r	0,06–0,10	0,08–0,12	0,10–0,14	0,13–0,19
			I MD	KCU40								
		U	O MD	KCU40	71	130	171	mm/r	0,06–0,10	0,08–0,12	0,10–0,14	0,13–0,19
			I MD	KC7140								
		I	O MD	KCU40	44	80	106	mm/r	0,06–0,10	0,08–0,12	0,10–0,14	0,13–0,19
			I MD	KC7140								
	2	S	O HP	KCU25	94	180	229	mm/r	0,10–0,14	0,12–0,18	0,12–0,18	0,12–0,20
			I HP	KCU40								
		U	O HP	KCU40	71	120	1714	mm/r	0,10–0,14	0,12–0,18	0,12–0,18	0,12–0,20
			I HP	KC7140								
		I	O HP	KCU40	44	70	106	mm/r	0,10–0,14	0,12–0,18	0,12–0,18	0,12–0,20
			I HP	KC7140								
	3	S	O HP	KCU25	70	140	169	mm/r	0,10–0,14	0,12–0,18	0,12–0,18	0,12–0,20
			I HP	KCU40								
		U	O HP	KCU40	50	100	121	mm/r	0,10–0,14	0,12–0,18	0,12–0,18	0,12–0,20
			I HP	KC7140								
		I	O HP	KCU40	30	60	72	mm/r	0,10–0,14	0,12–0,18	0,12–0,18	0,12–0,20
			I HP	KC7140								
	4	S	O HP	KCU25	94	120	229	mm/r	0,10–0,14	0,12–0,18	0,12–0,18	0,12–0,20
			I HP	KCU40								
		U	O HP	KCU40	71	100	171	mm/r	0,10–0,14	0,12–0,18	0,12–0,18	0,12–0,20
			I HP	KC7140								
		I	O HP	KCU40	44	80	106	mm/r	0,10–0,14	0,12–0,18	0,12–0,18	0,12–0,20
			I HP	KC7140								
5	S	O HP	KCU25	78	100	190	mm/r	0,05–0,07	0,06–0,08	0,06–0,10	0,08–0,12	
		I HP	KCU40									
	U	O HP	KCU40	47	60	114	mm/r	0,05–0,07	0,06–0,08	0,06–0,10	0,08–0,12	
		I HP	KC7140									
	I	O HP	KCU40	31	40	76	mm/r	0,05–0,07	0,06–0,08	0,06–0,10	0,08–0,12	
		I HP	KC7140									
6	S	O HP	KCU25	74	95	180	mm/r	0,04–0,07	0,05–0,08	0,06–0,10	0,08–0,12	
		I HP	KCU40									
	U	O HP	KCU40	45	57	108	mm/r	0,04–0,07	0,05–0,08	0,06–0,10	0,08–0,12	
		I HP	KC7140									
	I	O HP	KCU40	30	38	72	mm/r	0,04–0,07	0,05–0,08	0,06–0,10	0,08–0,12	
		I HP	KC7140									
M	1	S	O MD	KCU25	48	110	134	mm/r	0,07–0,11	0,12–0,18	0,14–0,20	0,16–0,22
			I MD	KCU40								
		U	O MD	KCU40	31	70	86	mm/r	0,07–0,11	0,12–0,18	0,14–0,20	0,16–0,22
			I MD	KC7140								
		I	O MD	KC7140	22	50	61	mm/r	0,07–0,11	0,12–0,18	0,14–0,20	0,16–0,22
			I MD	KC7140								
	2	S	O MD	KCU25	48	99	134	mm/r	0,07–0,11	0,12–0,18	0,14–0,20	0,16–0,22
			I MD	KCU40								
		U	O MD	KCU40	31	63	86	mm/r	0,07–0,11	0,12–0,18	0,14–0,20	0,16–0,22
			I MD	KC7140								
		I	O MD	KC7140	22	45	61	mm/r	0,07–0,11	0,12–0,18	0,14–0,20	0,16–0,22
			I MD	KC7140								
3	S	O MD	KCU25	48	88	134	mm/r	0,07–0,11	0,12–0,18	0,14–0,20	0,16–0,22	
		I MD	KCU40									
	U	O MD	KCU40	31	56	86	mm/r	0,07–0,11	0,12–0,18	0,14–0,20	0,16–0,22	
		I MD	KC7140									
	I	O MD	KC7140	22	40	61	mm/r	0,07–0,11	0,12–0,18	0,14–0,20	0,16–0,22	
		I MD	KC7140									

Condition: S = Stable cutting conditions;
 U = Unstable cutting conditions;
 I = Interrupted cutting conditions

Pocket seat: I = Inboard insert;
 O = Outboard insert

HTS DFT™ • Metric

		Metric											
Material Group	Condition	Pocket Seat	Geometry	Grade	Cutting Speed – vc			Recommended Feed Rate (f) by Diameter					
					Range – m/min			Ø	DFT03... 45,00–55,00mm	DFT05... 55,00–78,00mm	DFT06... 78,00–140,00mm	DFT07... 140,00–270,00mm	
					min	Starting Value	max						
K	1	S	O	HP	KCPK10	94	171	229	mm/r	0,11–0,20	0,13–0,27	0,15–0,31	0,17–0,33
			I	HP	KCPK10								
		U	O	HP	KCU25	64	117	156	mm/r	0,11–0,20	0,13–0,27	0,15–0,31	0,17–0,33
	2	S	O	HP	KCPK10	94	162	229	mm/r	0,11–0,20	0,13–0,27	0,15–0,31	0,17–0,33
			I	HP	KCPK10								
		U	O	HP	KCU25	64	111	156	mm/r	0,11–0,20	0,13–0,27	0,15–0,31	0,17–0,33
	3	S	O	HP	KCPK10	90	146	217	mm/r	0,11–0,20	0,13–0,27	0,15–0,31	0,15–0,31
			I	HP	KCPK10								
		U	O	HP	KCU25	59	100	144	mm/r	0,11–0,20	0,13–0,27	0,15–0,31	0,15–0,31
N	1	S	O	ST	KD1425	154	240	358	mm/r	0,06–0,09	0,11–0,19	0,12–0,20	0,14–0,25
			I	ST	KD1425								
		U	O	HP	KC7140	102	160	239	mm/r	0,06–0,09	0,11–0,19	0,12–0,20	0,14–0,25
	2	S	O	HP	KCU40	102	149	239	mm/r	0,06–0,09	0,11–0,19	0,12–0,20	0,14–0,25
			I	HP	KCU40								
		U	O	HP	KCU40	67	97	155	mm/r	0,06–0,09	0,11–0,19	0,12–0,20	0,14–0,25
	3	S	O	ST	KD1425	154	206	358	mm/r	0,06–0,09	0,11–0,19	0,12–0,20	0,14–0,25
			I	ST	KD1425								
		U	O	HP	KCU40	102	138	239	mm/r	0,06–0,09	0,11–0,19	0,12–0,20	0,14–0,25
4	S	O	HP	KCU40	67	89	155	mm/r	0,06–0,09	0,11–0,19	0,12–0,20	0,14–0,25	
		I	HP	KCU40									
	U	O	ST	KD1425	154	223	358	mm/r	0,06–0,09	0,11–0,19	0,12–0,20	0,14–0,25	
5	S	O	ST	KD1425	112	220	262	mm/r	0,06–0,09	0,11–0,19	0,12–0,20	0,14–0,25	
		I	ST	KD1425									
	U	O	HP	KCU40	72	140	167	mm/r	0,06–0,09	0,11–0,19	0,12–0,20	0,14–0,25	
S	1	S	O	HP	KC7140	24	40	49	mm/r	0,04–0,07	0,05–0,08	0,07–0,10	0,07–0,10
			I	HP	KC7140								
		U	O	HP	KC7140	18	30	37	mm/r	0,04–0,07	0,05–0,08	0,07–0,10	0,07–0,10
	2	S	O	HP	KC7140	15	25	30	mm/r	0,04–0,07	0,05–0,08	0,07–0,10	0,07–0,10
			I	HP	KC7140								
		U	O	HP	KC7140	25	35	48	mm/r	0,04–0,07	0,05–0,08	0,07–0,10	0,07–0,10
2	S	O	HP	KC7140	18	25	34	mm/r	0,04–0,07	0,05–0,08	0,07–0,10	0,07–0,10	
		I	HP	KC7140									
	U	O	HP	KC7140	14	20	27	mm/r	0,04–0,07	0,05–0,08	0,07–0,10	0,07–0,10	

Condition: S = Stable cutting conditions;
 U = Unstable cutting conditions;
 I = Interrupted cutting conditions

Pocket seat: I = Inboard insert;
 O = Outboard insert



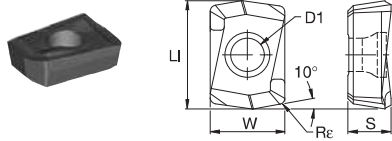

DFR-GD

● first choice
○ alternate choice

P	●	●	●	●
M	○	○	○	○
K	●	●	○	○
N	○	○	○	○
S	○	○	●	●
H	○	○	○	○

catalogue number	LI	W	D1	S	Rε	KCPK10	KCU25	KCU40	KC7140
DFR020204GD	7,12	4,90	2,30	2,79	0,40	●	●	●	●
DFR030204GD	8,71	6,00	2,50	2,88	0,40	●	●	●	●
DFR040304GD	10,76	7,38	2,85	3,79	0,40	●	●	●	●

Indexable Drills

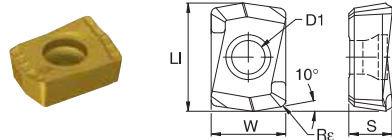

DFR-MD

● first choice
○ alternate choice

P	●	●	●	●
M	○	○	○	○
K	○	○	○	○
N	○	○	○	○
S	○	○	●	●
H	○	○	○	○

catalogue number	LI	W	D1	S	Rε	KCU25	KCU40	KC7140
DFR020204MD	7,12	4,90	2,30	2,79	0,40	●	●	●
DFR030204MD	8,71	6,00	2,50	2,88	0,40	●	●	●
DFR040304D28MD	10,76	7,26	2,85	3,79	0,40	-	-	●
DFR040304MD	10,76	7,38	2,85	3,79	0,40	●	●	●

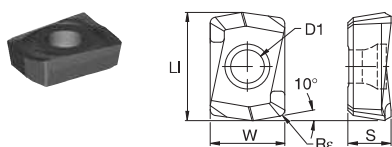

DFR-LD

● first choice
○ alternate choice

P	○	○	○	○
M	○	○	○	○
K	●	●	●	○
N	○	○	○	○
S	○	○	○	○
H	○	○	○	○

catalogue number	LI	W	D1	S	Rε	KCPK10	KCU25	KCU40	KC7140
DFR020204LD	7,12	4,90	2,30	2,79	0,40	●	●	●	●
DFR030204LD	8,71	6,00	2,50	2,86	0,40	●	●	●	●
DFR040304LD	10,76	7,38	2,85	3,76	0,40	●	●	●	●

P	■
M	■
K	■
N	●
S	■
H	■

- first choice
- alternate choice

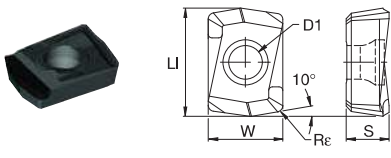
DFR • PCD • Single-Tipped

catalogue number	LI	W	D1	S	Rε		KD1425
DFR040304ST	10,50	7,40	2,85	3,18	0,40	●	

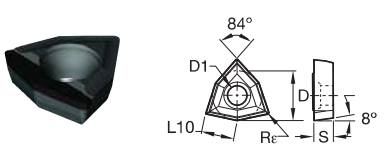
DFT • PCD • Single-Tipped

catalogue number	L10	D	D1	S	Rε		KD1425
DFT05T308ST	5,19	8,00	3,40	3,75	0,80	●	
DFT06T308ST	6,52	10,00	4,40	3,75	0,80	●	
DFT070408ST	7,84	12,00	4,40	4,75	0,80	●	
DFT090508ST	9,83	15,00	5,50	5,19	0,80	●	
DFT110508ST	11,53	17,60	5,85	4,81	0,80	●	



DFR™ • PCD • Metric

Material Group	Condition	Pocket Seat	Geometry	Grade	Metric					
					Cutting Speed – vc			Recommended Feed Rate (fz) by Diameter		
					Range – m/min					
					min	Starting Value	max	Ø	DFR04 20,50–24,00mm	
N	1	S	O	ST	KD1425	396	720	841	mm/r	0,06–0,08
			I	ST	KD1425					
	2	S	O	ST	KD1425	369	670	782	mm/r	0,12–0,18
			I	ST	KD1425					
	3	S	O	ST	KD1425	341	619	723	mm/r	0,12–0,18
			I	ST	KD1425					
	4	S	O	ST	KD1425	475	720	841	mm/r	0,12–0,18
			I	ST	KD1425					
	5	S	O	ST	KD1425	480	720	864	mm/r	0,06–0,08
			I	ST	KD1425					



Indexable Drills

DFT™ • PCD • Metric

Material Group	Condition	Pocket Seat	Geometry	Grade	Metric										
					Cutting Speed – vc			Recommended Feed Rate (f) by Diameter							
					Range – m/min										
					min	Starting Value	max	Ø	DFT03 16–24,00mm	DFT05 25–32,00mm	DFT06 33–40,00mm	DFT07 41–48,00mm	DFT09 49–68,00mm	DFT11 69–82,00mm	
N	1	S	ST/C	KD1425	480	720	864	mm/r	0,05–0,07	0,07–0,09	0,10–0,14	0,12–0,16	0,14–0,18	0,14–0,18	
			I	ST/C											KD1425
	2	S	O	ST/C	KD1425	447	670	804	mm/r	0,05–0,07	0,07–0,09	0,10–0,14	0,12–0,16	0,14–0,18	0,14–0,18
			I	ST/C	KD1425										
	3	S	O	ST/C	KD1425	413	619	743	mm/r	0,05–0,07	0,07–0,09	0,10–0,14	0,12–0,16	0,14–0,18	0,14–0,18
			I	ST/C	KD1425										
	4	S	O	ST/C	KD1425	447	670	804	mm/r	0,05–0,07	0,07–0,09	0,10–0,14	0,12–0,16	0,14–0,18	0,14–0,18
			I	ST/C	KD1425										
	5	S	O	ST/C	KD1425	480	720	864	mm/r	0,05–0,07	0,07–0,09	0,10–0,14	0,12–0,16	0,14–0,18	0,14–0,18
			I	ST/C	KD1425										

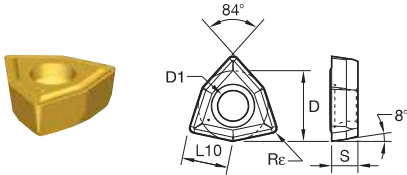

● first choice
○ alternate choice

P	●	●	●	●
M	○	○	○	○
K	●	●	●	○
N	○	○	○	○
S	○	○	○	○
H	○	○	○	○

DFT-GD

catalogue number	L10	D	D1	S	Rε	KCPK10	KCU25	KCU40	KC7140
DFT030204GD	3,97	6,00	2,25	2,45	0,40	●	●	●	○
DFT030304GD	3,97	6,00	2,65	2,95	0,40	●	●	●	○
DFT05T308GD	5,29	8,00	3,40	3,75	0,80	●	●	●	○
DFT06T308GD	6,62	10,00	4,40	3,75	0,80	●	●	●	○
DFT070408GD	7,94	12,00	4,40	4,75	0,80	●	●	●	○
DFT090508GD	9,92	15,00	5,50	5,25	0,85	●	●	●	○

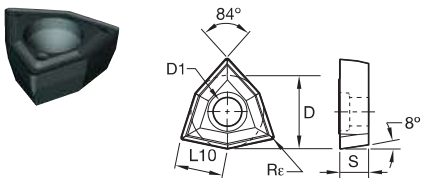

● first choice
○ alternate choice

P	●	●	●	●
M	○	○	○	○
K	●	●	○	○
N	○	○	○	○
S	○	○	○	○
H	○	○	○	○

DFT-HP

catalogue number	L10	D	D1	S	Rε	KCPK10	KCU25	KCU40	KC7140	KMF
DFTX20204HP	3,31	5,00	2,25	2,45	0,40	○	●	●	○	○
DFT030204HP	3,97	6,00	2,25	2,45	0,40	●	●	●	○	○
DFT030304HP	3,97	6,00	2,65	2,95	0,40	●	●	●	○	○
DFT05T308HP	5,29	8,00	3,50	3,75	0,80	●	●	●	○	○
DFT06T308HP	6,62	10,00	4,40	3,75	0,80	●	●	●	○	○
DFT070408HP	7,94	12,00	4,40	4,75	0,80	●	●	●	○	○
DFT090508HP	9,92	15,00	5,50	5,25	0,85	●	●	●	○	○

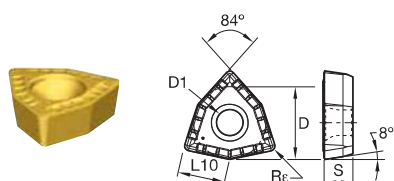

● first choice
○ alternate choice

P	●	●	●	●
M	○	○	○	○
K	●	●	○	○
N	○	○	○	○
S	○	○	○	○
H	○	○	○	○

DFT-MD

catalogue number	L10	D	D1	S	Rε	KCU25	KCU40	KC7140
DFTX20204MD	3,31	5,00	2,25	2,45	0,40	●	●	○
DFT030204MD	3,97	6,00	2,25	2,45	0,40	●	●	○
DFT030304MD	3,97	6,00	2,65	2,95	0,40	●	●	○
DFT05T308MD	5,29	8,00	3,40	3,75	0,80	●	●	○
DFT06T308MD	6,62	10,00	4,40	3,75	0,80	●	●	○
DFT070408MD	7,94	12,00	4,40	4,75	0,80	●	●	○
DFT090508MD	9,92	15,00	5,50	5,25	0,80	●	●	○
DFT110508MD	11,64	17,60	5,85	4,88	0,80	○	○	○

- DS geometry for improved control of chip flow, chip breakage, and chip curling.
- These inserts support drilling in P0 and P1 steel, higher alloyed tool steels, and stainless steels where high feed rates cannot be used to provide short chips.



Indexable Drills

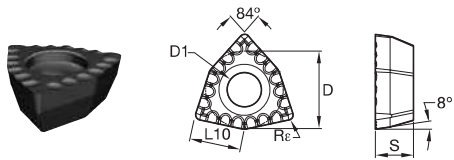

■ DFT • DS

catalogue number	L10	D	D1	S	Rr	
DFTX20204DS	3,31	5,00	2,25	2,45	0,40	●
DFT030304DS	3,97	6,00	2,65	2,95	0,40	●
DFT05T308DS	5,29	8,00	3,40	3,75	0,80	●
DFT06T308DS	6,62	10,00	4,40	3,75	0,80	●
DFT070408DS	7,94	12,00	4,40	4,75	0,80	●
DFT090508DS	9,92	15,00	5,50	5,25	0,80	●

● first choice
○ alternate choice

P	●
M	○
K	○
N	○
S	○
H	○



KCU40

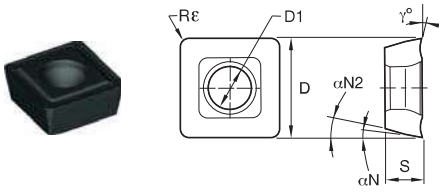

● first choice
○ alternate choice

P	●	●	●	●
M	○	○	○	○
K	●	●	●	○
N	○	○	○	○
S	○	○	○	○
H				

■ SP..X..(R)HP

catalogue number	D	D1	S	Rε	γ°	αN	αN2	KCPK10	KCU25	KCU40	KC7140
SPGX050204HP	5,56	2,25	2,38	0,40	10	7	11	-	●	●	●
SPGX060304RHP	6,35	2,65	3,18	0,40	10	7	11	-	●	●	●
SPGX070304RHP	7,94	2,85	3,18	0,40	10	7	11	-	●	●	●
SPGX070308HP	7,94	2,85	3,18	0,80	10	7	11	-	●	●	-
SPPX09T308RHP	9,53	3,60	3,97	0,80	10	7	11	-	●	●	●
SPPX09T310HP	9,53	3,60	3,97	1,00	10	7	11	●	●	●	-
SPPX120408RHP	12,70	4,60	4,76	0,80	10	7	11	-	●	●	●
SPPX120412HP	12,70	4,60	4,76	1,20	10	7	11	●	●	●	-
SPPX15T508RHP	15,73	5,50	5,95	0,80	10	7	11	-	●	●	●
SPPX15T512HP	15,73	5,50	5,95	1,20	10	7	11	●	●	●	-

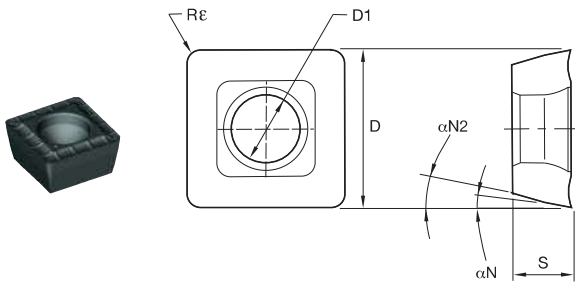

■ SP..X..MD

catalogue number	D	D1	S	Rε	γ°	αN	αN2	KCPK10	KCU25	KCU40	KC7140
SPGX050204MD	5,56	2,25	2,38	0,40	16	7	11	-	●	●	●
SPGX060304MD	6,35	2,65	3,18	0,40	20	7	11	●	●	●	●
SPGX070304MD	7,94	2,85	3,18	0,40	16	7	11	●	●	●	●
SPGX070308MD	7,94	2,85	3,18	0,80	16	7	11	●	●	●	-
SPPX09T308MD	9,53	3,60	3,97	0,80	16	7	11	-	●	●	●
SPPX09T310MD	9,53	3,60	3,97	1,00	16	7	11	●	●	●	-
SPPX120408MD	12,70	4,60	4,76	0,80	16	7	11	-	●	●	●
SPPX120412MD	12,70	4,60	4,76	1,20	16	7	11	●	●	●	-
SPPX15T508MD	15,73	5,50	5,95	0,80	16	7	11	-	●	●	●
SPPX15T512MD	15,73	5,50	5,95	1,20	16	7	11	●	●	●	-



Indexable Drills

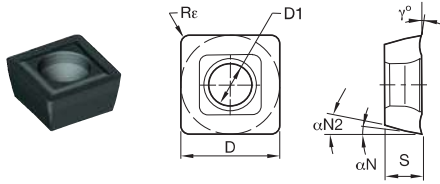

● first choice
○ alternate choice

P	●	●	●
M	○	○	○
K	●	●	●
N	○	○	○
S	○	○	○
H			

■ SP..X..FP

Indexable Drills

catalogue number	D	D1	S	Re	γ°	αN	$\alpha N2$	KCPK10	KCU25	KCU40
SPGX060304FP	6,35	2,85	3,18	0,40	6	7	11	●	●	●
SPGX070304FP	7,94	2,85	3,18	0,40	6	7	11	●	●	●
SPGX070308FP	7,94	2,85	3,18	0,80	6	7	11	●	●	●
SPPX09T308FP	9,53	3,60	3,97	0,80	6	7	11	●	●	●
SPPX09T310FP	9,53	3,60	3,97	1,00	6	7	11	●	●	●
SPPX120408FP	12,70	4,60	4,76	0,80	6	7	11	●	●	●
SPPX120412FP	12,70	4,60	4,76	1,20	6	7	11	●	●	●
SPPX15T508FP	15,73	5,50	5,95	0,80	6	7	11	●	●	●
SPPX15T512FP	15,73	5,50	5,95	1,20	6	7	11	●	●	●

- LP geometry for improved control of chip flow, chip breakage, and chip curling.
- These inserts support drilling in P0 and P1 steel, higher alloyed tool steels, and stainless steels where high feed rates cannot be used to provide short chips.

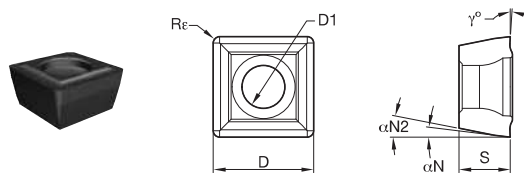

● first choice
○ alternate choice

P	●
M	○
K	○
N	○
S	○
H	



■ SP..X..LP

catalogue number	D	D1	S	Re	γ°	αN	$\alpha N2$	KCU40
SPGX050204LP	5,42	2,25	2,38	0,40	4	7	11	●
SPGX060304LP	6,35	2,65	3,18	0,40	4	7	11	●
SPPX070304LP	7,80	2,85	3,18	0,40	4	7	11	●
SPPX09T308LP	9,38	3,60	3,97	0,80	4	7	11	●
SPPX120408LP	12,56	4,60	4,76	0,80	4	7	11	●

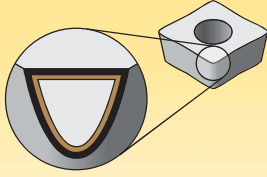

Coatings provide high-speed capability and are engineered for finishing to light roughing.

P	Steel
M	Stainless Steel
K	Cast Iron
N	Non-Ferrous
S	High-Temp Alloys
H	Hardened Materials

wear resistance ← → toughness

Grade	Coating	Grade Description	Material															
			P	M	K	N	S	H	05	10	15	20	25	30	35	40	45	
KCPK10		Composition: With an advanced CVD TiCN-Al ₂ O ₃ coating combined with a cobalt-enriched carbide substrate, this grade offers a balanced combination of deformation-resistance and edge toughness. Application: The KCPK10™ grade offers outstanding abrasion and crater wear resistance for high-speed machining of steels and cast irons. Use for very high cutting speeds with low to medium feed rates.	P															
	Al ₂ O ₃ TiCN																	
KCU25		Composition: This advanced CVD TiCN-Al ₂ O ₃ coating, together with a newly engineered tough carbide substrate, ensures adequate deformation resistance along with excellent edge strength, and offers very good wear resistance over a wide range of machining conditions. Application: KCU25, as a high productivity grade with high speeds and feeds, is the first choice for productive process with very good reliability in steels, stainless steels, and cast irons.	P															
	Al ₂ O ₃ TiCN																	
KCU40		Composition: With a multilayered PVD TiN-TiAlN coating and a tough substrate, this grade withstands interruptions and provides high wear resistance for long tool life. Application: The KCU40 grade is the first choice for high reliability in most materials. This grade should be used at medium speeds and high feeds due to sharper edges, and as a grade for high toughness applications. It covers steel, stainless steel, cast iron, and high-temp alloys under certain conditions.	P															
	PVD TiN_TiAlN																	

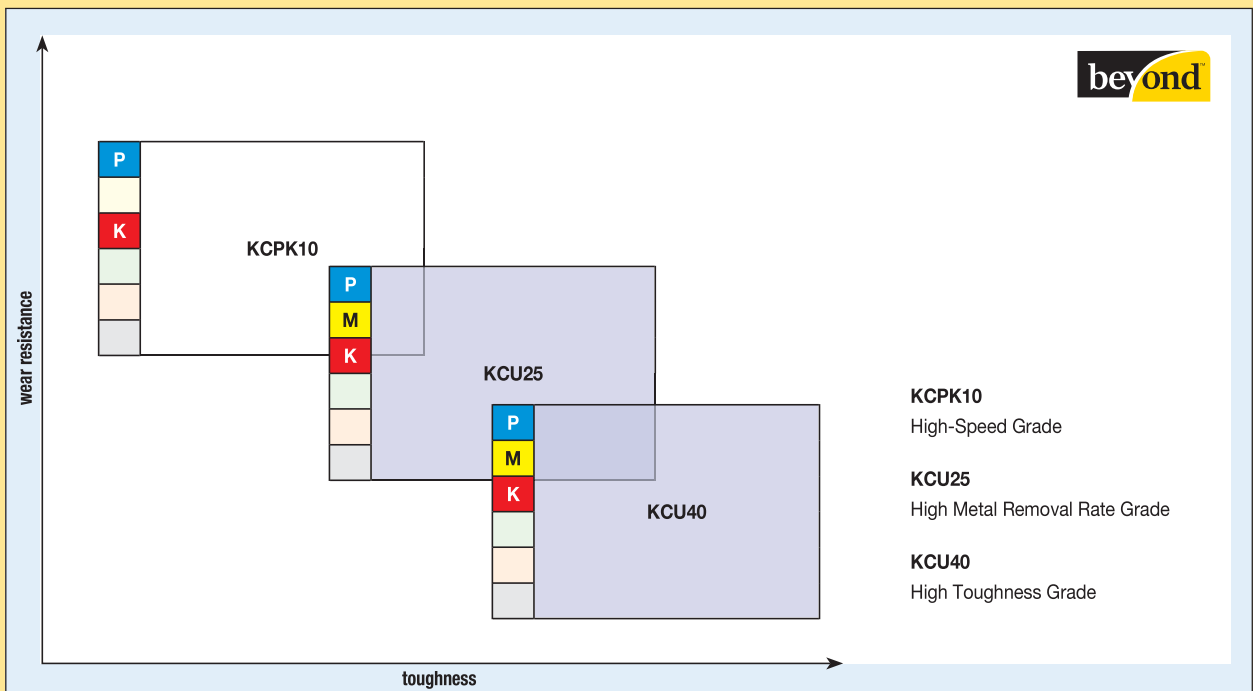

■ Feed Force Requirement

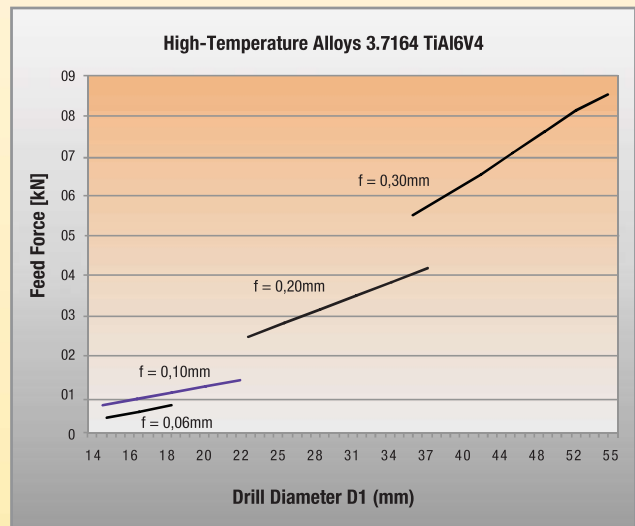
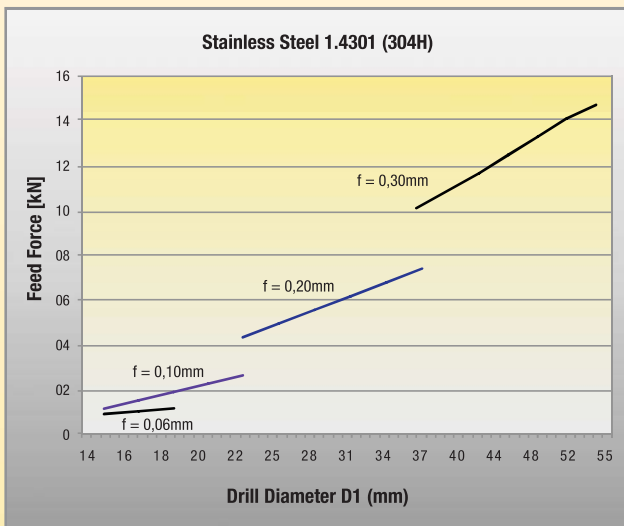
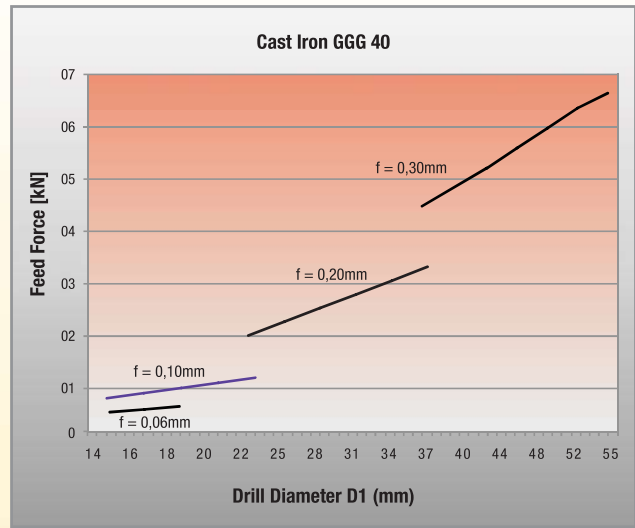
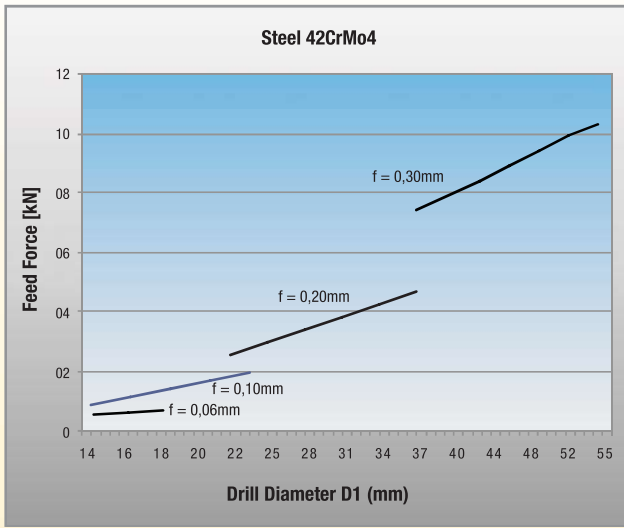

■ Power Recommendation

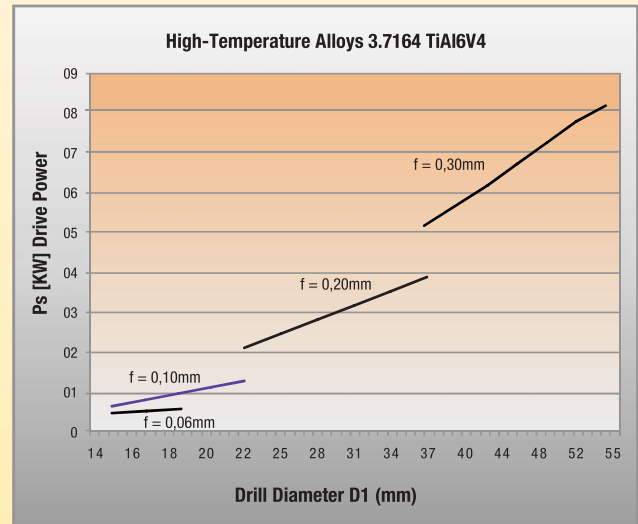
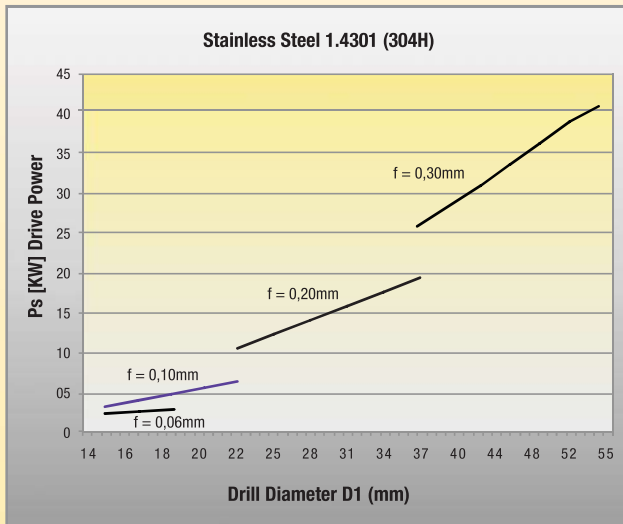
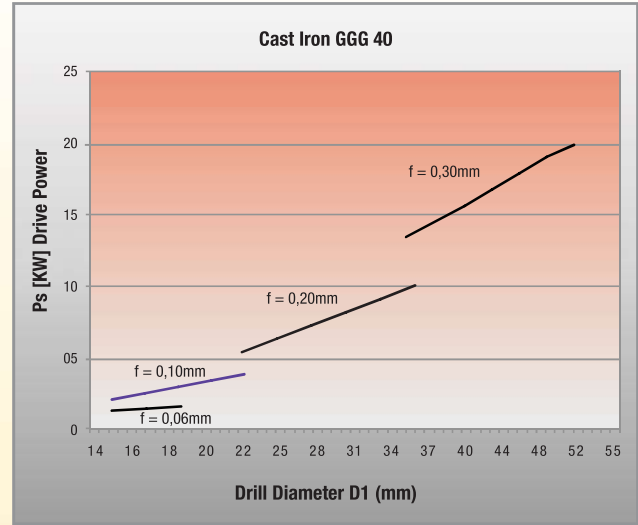
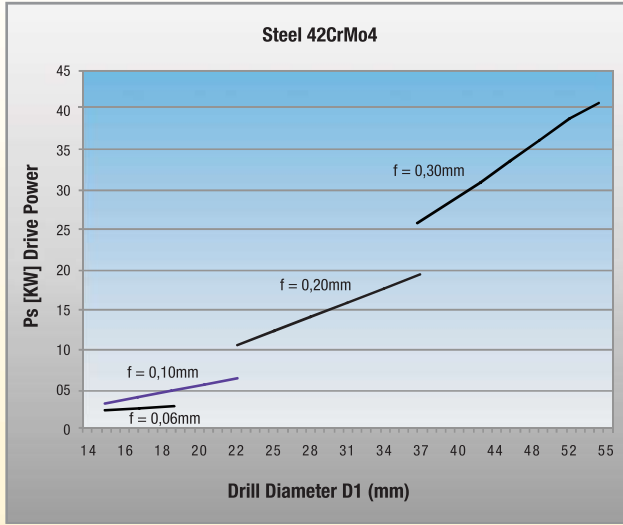

Torque Recommendation

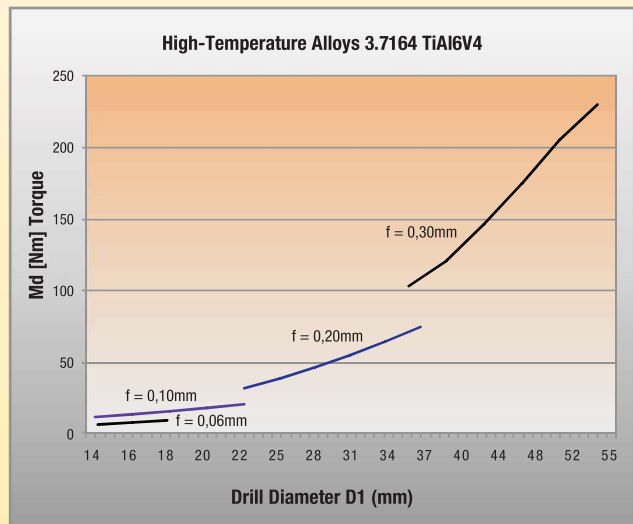
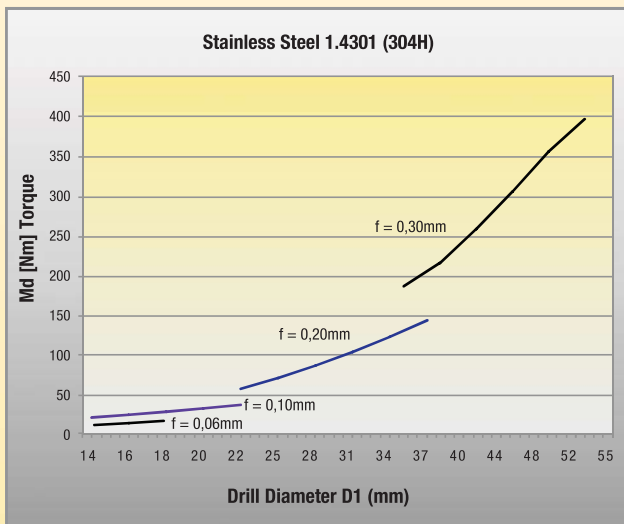
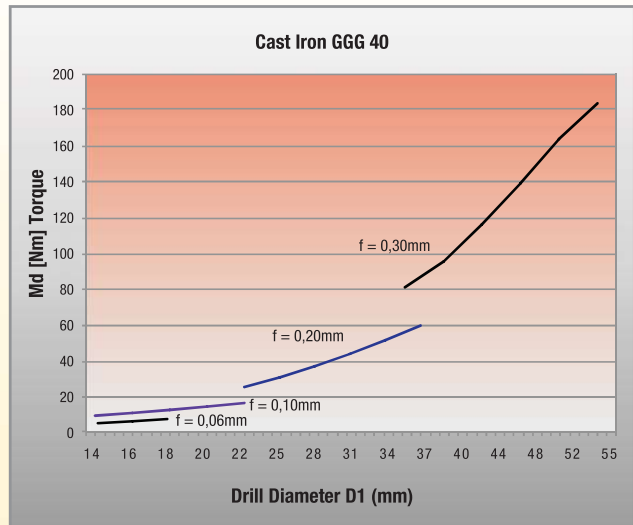
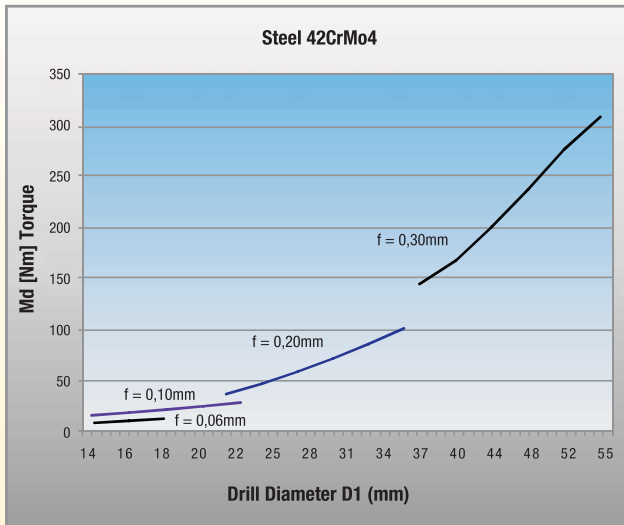

NOVO KNOWS CAD/CAM

With the addition of NOVO™ applications to your team, your CAD/CAM capabilities become much more accurate, streamlined, and productive.

Before NOVO: The programmer would be in their CAD/CAM software, programming a part. Using the tedious method of finding a tool in a catalogue, and then manually inputting the tooling information from the catalogue into the CAD/CAM software.

The concern is that assumptions are made, and only partial tooling information is entered.

With NOVO: The powerful digital intelligence of NOVO applications not only help the programmer find the right tool for the metalcutting job, but also automatically integrates all the tooling data into a complete CAD/CAM solution. The integration of all the tooling data increases the viability of the part being programmed, and is delivered quickly — saving you time.

NOVO applications can ensure you have the right tools on your machines, in the right sequence. Resulting in flawless execution that accelerates every job, and maximises every shift. kennametal.com/novo



➤ CTR™ Counterboring Tools

CTR counterboring tools are designed for high-production screw-head counterbores and similar counterboring operations. Tools can be adapted to almost all applications for optimum cutting performance and long tool life.

Extremely unequal insert positioning and flutes prevent chattering and generate less noise. A precise 90° bottom can be achieved with the S2 S inserts.

Features and Benefits

Productivity and Reliability

- S2 S inserts reduce additional drill operations to achieve a precise 90° bottom.
- Chatter-free operations for improved surface quality due to extremely unequal insert positioning and flutes.
- Achieve high metal removal rates to reduce machine time and manufacturing costs.

Versatility

- Counterboring tools can be used in steel, stainless steel, non-ferrous materials, cast irons, and heat-resistant alloy applications.
- Toolholders are double- or triple-fluted at a diameter range of 15–46mm (.591–1.811") with through-coolant capabilities.
- S2 S standard inserts are double-edged and available in various grades and geometries.

Achieve high metal removal rates to reduce machine time and manufacturing costs.



Customisation

- Length and diameter variations with and without adjustable cartridges available.
- Combination and multistep tooling based on drilling tools, like the Drill Fix™ system, with short distance and small diameter steps.
- Various radii and customised grades available upon request.

- Counterboring tool shipped with insert screws and Torx wrench.
- Order inserts separately; see pages J99–J101.

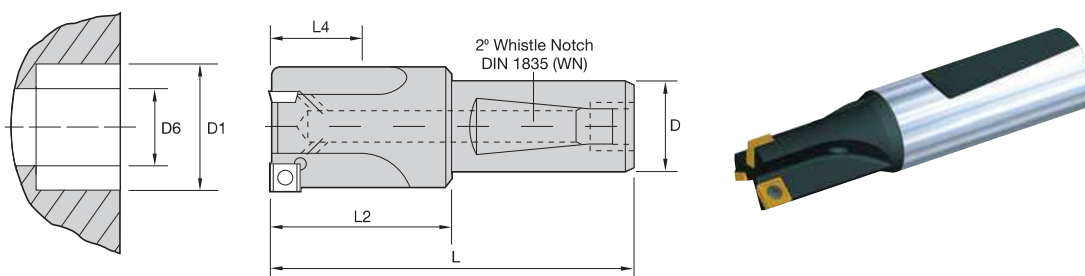

■ S2 S Whistle Notch WN Shank • Metric

catalogue number	D1	tol min D1	tol max D1	D	D6	L	L2	L4 max	gage insert	number of inserts
CBTF150R2WD20N2M	15,14	-0,120	0,120	20	6,0	81	31	8,5	SPHX060204R..	2
CBTF160R2WD20N2M	16,14	-0,120	0,120	20	7,0	81	31	8,5	SPHX060204R..	2
CBTF170R2WD20N2M	17,14	-0,120	0,120	20	8,0	86	36	13,5	SPHX060204R..	2
CBTF180R2WD20N2M	18,14	-0,120	0,120	20	8,4	86	36	13,5	SPHX070304R..	2
CBTF180R2WD20N3M	18,14	-0,120	0,120	20	8,4	86	36	13,5	SPHX060204R..	3
CBTF200R2WD20N2M	20,17	-0,120	0,120	20	8,5	86	36	16,0	SPHX070304R..	2
CBTF200R2WD20N3M	20,17	-0,120	0,120	20	8,5	86	36	16,0	SPHX060204R..	3
CBTF210R2WD20N2M	21,17	-0,120	0,120	20	8,5	86	36	16,0	SPHX070304R..	2
CBTF210R2WD20N3M	21,17	-0,120	0,120	20	10,5	86	36	11,0	SPHX060204R..	3
CBTF220R2WD20N2M	22,17	-0,120	0,120	20	10,4	86	36	16,0	SPHX070304R..	2
CBTF220R2WD20N3M	22,17	-0,120	0,120	20	10,5	86	36	16,0	SPHX060204R..	3
CBTF230R2WD20N2M	23,17	-0,120	0,120	20	10,5	91	41	21,0	SPHX090304R..	2
CBTF230R2WD20N3M	23,17	-0,120	0,120	20	10,5	91	41	16,0	SPHX070304R..	3
CBTF240R2WD20N2M	24,17	-0,120	0,120	20	10,5	91	41	18,5	SPHX090304R..	2
CBTF240R2WD20N3M	24,17	-0,120	0,120	20	10,5	91	41	16,0	SPHX070304R..	3
CBTF250R2WD20N2M	25,17	-0,120	0,120	20	12,0	96	46	23,5	SPHX090304R..	2
CBTF250R2WD20N3M	25,17	-0,120	0,120	20	10,5	96	46	21,0	SPHX070304R..	3
CBTF260R2WD20N2M	26,17	-0,120	0,120	20	13,0	96	46	23,5	SPHX090304R..	2
CBTF270R2WD20N3M	27,17	-0,120	0,120	20	10,5	96	46	21,0	SPHX090304R..	3
CBTF280R2WD20N3M	28,17	-0,120	0,120	20	15,0	101	51	23,5	SPHX090304R..	3
CBTF300R2WD20N3M	30,17	-0,120	0,120	20	15,0	101	51	23,0	SPHX090304R..	3
CBTF320R2WD20N3M	32,20	-0,120	0,120	20	17,0	101	51	23,0	SPHX090304R..	3
CBTF330R2WD20N3M	33,20	-0,120	0,120	20	17,0	101	51	25,5	SPHX090304R..	3
CBTF340R2WD32N3M	34,20	-0,120	0,120	32	18,0	111	51	25,5	SPHX090304R..	3
CBTF350R2WD32N3M	35,20	-0,120	0,120	32	19,0	111	51	25,5	SPHX090304R..	3
CBTF360R2WD32N3M	36,20	-0,120	0,120	32	19,0	116	56	27,5	SPHX090304R..	3
CBTF380R2WD32N3M	38,20	-0,120	0,120	32	22,0	121	61	30,0	SPHX120404R..	3
CBTF400R2WD32N3M	40,20	-0,120	0,120	32	21,0	121	61	30,5	SPHX120404R..	3
CBTF420R2WD32N3M	42,20	-0,120	0,120	32	22,0	126	66	33,5	SPHX120404R..	3
CBTF460R2WD32N3M	46,20	-0,120	0,120	32	25,0	126	66	33,5	SPHX120404R..	3

■ Spare Parts



gage insert	insert screw	wrench	Torx size
SPHX060204R..	192.432	170.028	T8
SPHX070304R..	192.432	170.028	T8
SPHX090304R..	191.924	170.024	T9
SPHX120404R..	191.916	170.025	T15

- Double-sided insert style.

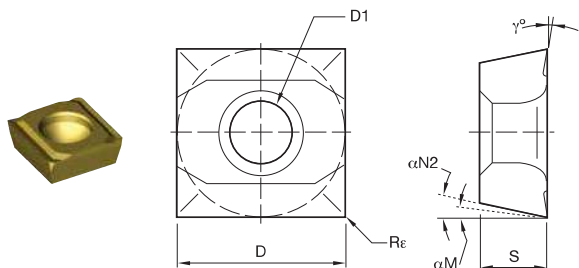

- first choice
- alternate choice

P	●	●	●	●
M	○	○	○	●
K	○	○	○	○
N	○	○	○	○
S	○	○	○	○
H	○	○	○	○

■ SPHX..R-20

catalogue number	D	D1	S	R ϵ	γ°	$\alpha N2$	$\alpha N M$	KCU25	KCU40	KC7215	KC7140
SPHX060202R20	6,35	2,85	2,38	0,20	12	11	7	-	-	●	-
SPHX060204R20	6,35	2,85	2,38	0,40	12	11	7	●	●	-	●
SPHX060206R20	6,35	2,85	2,38	0,60	12	11	7	-	-	●	-
SPHX060208R20	6,35	2,85	2,38	0,80	12	11	7	-	-	●	-
SPHX070302R20	7,94	2,85	3,18	0,20	12	11	7	-	-	●	-
SPHX070304R20	7,94	2,85	3,18	0,40	12	11	7	●	●	-	●
SPHX070306R20	7,94	2,85	3,18	0,60	12	11	7	-	-	●	-
SPHX070308R20	7,94	2,85	3,18	0,80	12	11	7	-	-	●	-
SPHX070310R20	7,94	2,85	3,18	1,00	12	11	7	-	-	●	-
SPHX070312R20	7,94	2,85	3,18	1,20	12	11	7	-	-	●	-
SPHX090304R20	9,53	3,50	3,18	0,40	12	11	7	●	●	●	●
SPHX090308R20	9,53	3,50	3,18	0,80	12	11	7	●	●	-	-
SPHX090310R20	9,53	3,50	3,18	1,00	12	11	7	-	-	●	-
SPHX090312R20	9,53	3,50	3,18	1,20	12	11	7	-	-	●	-
SPHX090316R20	9,53	3,50	3,18	1,60	12	11	7	-	-	●	-
SPHX120404R20	12,70	4,50	4,76	0,40	12	11	7	●	●	-	●
SPHX120408R20	12,70	4,50	4,76	0,80	12	11	7	●	●	-	-
SPHX120410R20	12,70	4,50	4,76	1,00	12	11	7	-	-	●	-
SPHX120412R20	12,70	4,50	4,76	1,20	12	11	7	-	-	●	-
SPHX120416R20	12,70	4,50	4,76	1,60	12	11	7	-	-	●	-
SPHX120420R20	12,70	4,50	4,76	2,00	12	11	7	-	-	●	-
SPHX150504R20	15,88	5,50	5,95	0,40	12	11	7	●	●	-	-
SPHX150508R20	15,88	5,50	5,95	0,80	12	11	7	●	●	-	-
SPHX150512R20	15,88	5,50	5,95	1,20	12	11	7	-	-	●	-
SPHX150516R20	15,88	5,50	5,95	1,60	12	11	7	-	-	●	-
SPHX150520R20	15,88	5,50	5,95	2,00	12	11	7	-	-	●	-

NOTE: SPHX...R-20: This geometry is first choice for steel applications.



Indexable Drills

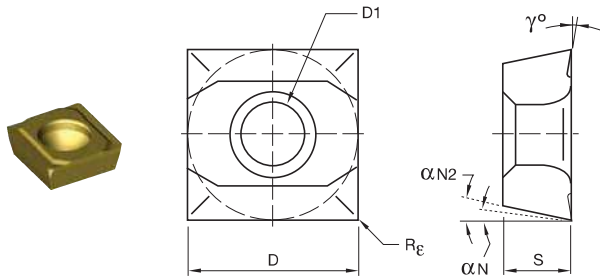

● first choice
○ alternate choice

P	○	○	○	○	○	○	○
M	○	○	○	○	○	○	○
K	●	●	●	●	●	●	●
N	○	○	○	○	○	○	○
S	○	○	○	○	○	○	○
H	○	○	○	○	○	○	○

SPHX..R-21

Indexable Drills

catalogue number	D	D1	S	Rε	γ°	αN2	αN	KCPK10	KCU25	KCU40	KC7215	KM1
SPHX060202R21	6,35	2,85	2,38	0,20	4	11	7	-	-	-	●	-
SPHX060204R21	6,35	2,85	2,38	0,40	4	11	7	●	●	●	-	-
SPHX060204R-21	6,35	2,85	2,38	0,40	4	11	7	-	-	-	-	●
SPHX060206R21	6,35	2,85	2,38	0,60	4	11	7	-	-	-	●	-
SPHX060208R21	6,35	2,85	2,38	0,80	4	11	7	-	-	-	●	-
SPHX070304R21	7,94	2,85	3,18	0,40	4	11	7	●	●	●	-	-
SPHX070304R-21	7,94	2,85	3,18	0,40	4	11	7	-	-	-	-	●
SPHX070306R21	7,94	2,85	3,18	0,60	4	11	7	-	-	-	●	-
SPHX070308R21	7,94	2,85	3,18	0,80	4	11	7	●	-	●	-	-
SPHX070310R21	7,94	2,85	3,18	1,00	4	11	7	-	-	-	●	-
SPHX090304R21	9,53	3,50	3,18	0,40	4	11	7	●	●	●	-	-
SPHX090304R-21	9,53	3,50	3,18	0,40	4	11	7	-	-	-	-	●
SPHX090308R21	9,53	3,50	3,18	0,80	4	11	7	●	●	●	-	-
SPHX090310R21	9,53	3,50	3,18	1,00	4	11	7	-	-	-	●	-
SPHX090312R21	9,53	3,50	3,18	1,20	4	11	7	-	-	-	●	-
SPHX090316R21	9,53	3,50	3,18	1,60	4	11	7	-	-	-	●	-
SPHX120404R21	12,70	4,50	4,76	0,40	4	11	7	●	●	●	-	-
SPHX120404R-21	12,70	4,50	4,76	0,40	4	11	7	-	-	-	-	●
SPHX120408R21	12,70	4,50	4,76	0,80	4	11	7	-	-	-	●	-
SPHX120410R21	12,70	4,50	4,76	1,00	4	11	7	-	-	-	●	-
SPHX120412R21	12,70	4,50	4,76	1,20	4	11	7	-	-	-	●	-
SPHX120416R21	12,70	4,50	4,76	1,60	4	11	7	-	-	-	●	-
SPHX120420R21	12,70	4,50	4,76	2,00	4	11	7	-	-	-	●	-
SPHX150504R-21	15,88	5,50	5,95	0,40	4	11	7	-	-	-	-	●

NOTE: SPHX...R-21: This geometry is first choice for cast iron applications.

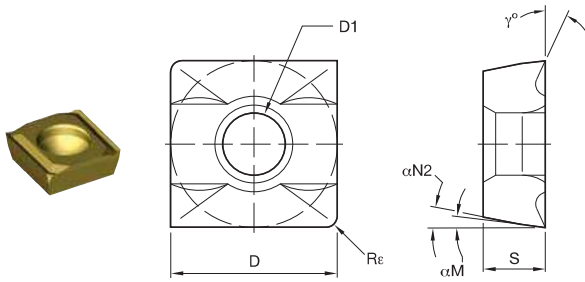

- first choice
- alternate choice

P	■	
M	■	
K	■	○
N	■	●
S	■	
H	■	

■ **SPHX..R-22**

catalogue number	D	D1	S	Re	γ°	αN2	αN M	KM1
SPHX060204R-22	6,35	2,85	2,38	0,40	25	11	—	●
SPHX070304R-22	7,94	2,85	3,18	0,40	25	11	—	●
SPHX090304R-22	9,53	3,50	3,18	0,40	25	11	—	●
SPHX120404R-22	12,70	4,50	4,76	0,40	25	11	—	●
SPHX150504R-22	15,88	5,50	5,95	0,40	25	11	7	●

NOTE: SPHX...R-22: This geometry is first choice for aluminium applications.



Indexable Drills