



TSCHORN®

Probes & Tools Technology

2023

Version 1



Our commitment to environmental protection

Because it is our earth. And we only have it once.



We produce with 100% green electricity.

We use long-lasting and energy-saving LED lighting throughout the company.



Look for the **Green Packing logo** in the catalogue.:



All these products have already been switched to sustainable packaging.

Example:
Thanks to Green Packing, we save over 3000 liters of foam every year - only with the 3D Tester SLIMplus.



We ship environmentally conscious and 100% recyclable:

Shipping: with shipping boxes at least 70% recycled raw material

Protecting: with wrapping paper containing at least 70% waste paper

Packing: with plastic-free product packaging

Labelling: with sustainable paper labels

Sealing: with plastic-free paper tape

Marking: with environmentally friendly mailing bags made of paper



**Our probing and
make the world
simple, precise**

**clamping technologies
of manufacturing
and competitive.**

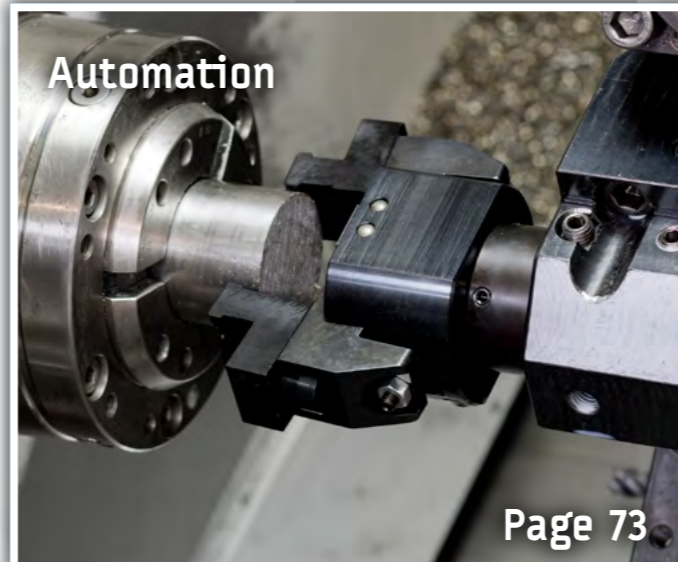
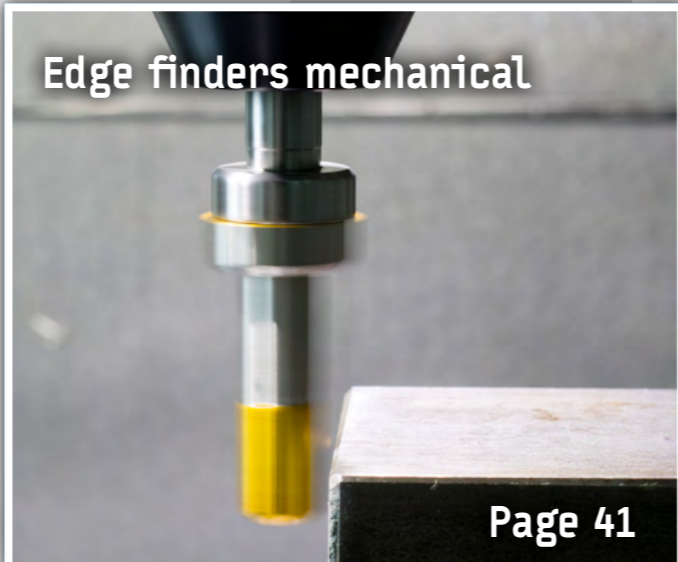
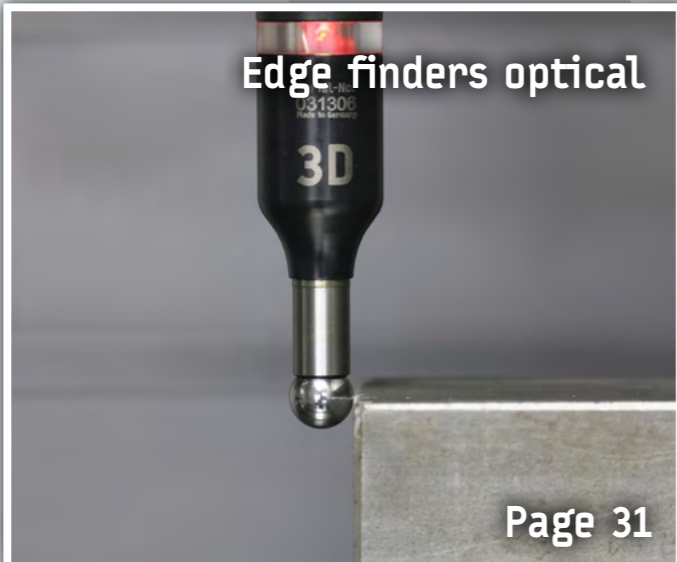
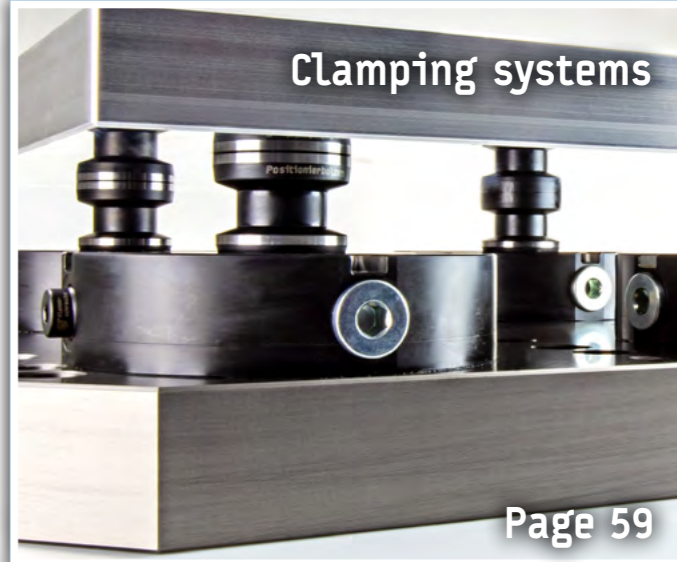

Your sales contact



Maik Schoch



☎ +49 7181 606986 7
@ maik.schoch@tschorn-gmbh.de



Sina Kortmann



☎ +49 7181 606986 7
@ sina.kortmann@tschorn-gmbh.de

Repair service



Crashed?

All our devices can be repaired.

Our worldwide resellers support you for any repair or service question.



Tschorn 4.0

Tschorn 4.0: Automatic probing system for every application

With the Tschorn 4.0 probing systems, you can measure tools and/or workpieces quickly and easily on your machine.

The investment is not worthwhile on your old machine?

It is! - With the cost-effective TSCHORN 4.0 system, the investment is also worthwhile for you!

Benefit from numerous advantages:

- time saving
- repeatability +/- 3 µm
- The accuracy is independent from the user.
- The receiver can flexibly be placed outside.
- The user has a good overview of the status LEDs at all times.

Now all you have to do is decide which system variant is right for you:



WP110 & TP100 are our well-known automatic probing system TSCHORN 4.0.



WP200 & TP125 are the further development of our well-known automatic probing system TSCHORN 4.0 (see above: WP110 and TP100).



TP135 is like TP125, but with direct cable connection.

Example of use probing edges:



Advantages (WP110/TP100):

- electrical functionality reacts to electrical contact
- 10 mm ball
- cost-efficient

Application range:
Mainly zero point probing and tool probing in a dry environment



WP110

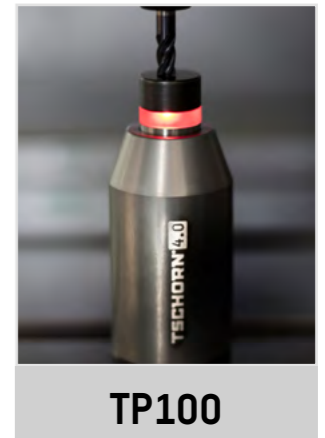

TP100

Probing systems
WP110 & TP100



RC100

The receiver can flexibly be placed outside.



WP200



TP125

Probing systems
WP200 & TP125

Advantages (WP200/TP125):

- tactile functionality - reacts to touch
- exchangeable styli
- Measurements are possible in the machining process with corrections
- Tool correction during machining
- Tool breakage control

Application range:
Zero point probing and tool probing, even in a wet environment

Tschorn 4.0

Tschorn 4.0

Functionality WP110 & TP100

The workpiece probe as well as the tool probe detect any contact with an electrical conductive workpiece or tool.

In the moment of the contact, a probing signal is sent to the receiver. The receiver is connected to the machine control and forwards the probing signal for further processing by the measuring macros (measuring cycles) integrated in the machine control.



Functionality WP200 & TP125

The workpiece probe as well as the tool probe detect any movement of the probing head or deflecting of the probing ball.

At the moment of deflection, a probing signal is sent to the receiver. The receiver is connected to the machine control and forwards the probing signal for further processing by the measuring macros (measuring cycles) integrated in the machine control.



Calibration

Please calibrate the probes before first use. We recommend repeating the calibration process regularly, as this compensates for the calibration deviations that arise in the interaction between the measuring system and the machine control.

For easy calibration, our calibration aid (art.no. 0014KH100) is available as an accessory.



Software: Smart-Macros from Tschorn

Smart-Macros from Tschorn are available free of charge for Siemens and Fanuc.

Tschorn Smart-Macros have been especially developed and synchronised for the TSCHORN 4.0 probing systems. Original Tschorn Smart-Macros enable best probing and repeatability precision.

Spindle orientation: Generally, probing is possible on all machines, whether with or without spindle orientation. Highest accuracy can be achieved with spindle orientation. Errors in the machine, the run-out or the probe are compensated during calibration. Without spindle orientation, this compensation is limited.

3 way probing:

In order to probe as quickly and precisely as possible, the probing process is divided into 3 consecutive probeings:

1. The first probing is made with fast feed and saves movement time.
2. This is followed by a second probing with medium feed.
3. Finally, the third probing follows with a slow measuring feed for maximum precision.

Manual Fanuc macros tool probing



Manual Fanuc macros workpiece probing



also for
Siemens
available

Installation questions?

Simply tell us about your machine and machine control and we will tell you immediately how quickly the installation can be carried out on your machine! You can also find more information about the installation in the video:



Dimensions

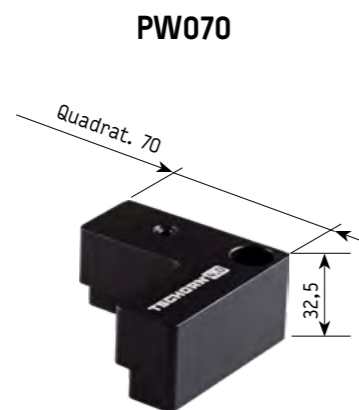
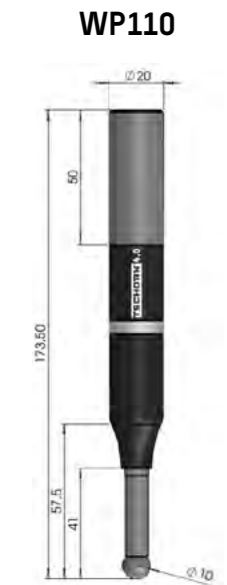

We currently have styli with diameters of 2 mm, 3 mm and 4 mm available. The probe is designed for Ø3x20 mm as standard.

Please note:

WP200 is designed for the standard stylus Ø3x20mm. With this, you achieve the highest accuracy. When using other sizes, the tolerance/accuracy may change.

Art.no.: 0014ST320 - Ø3 x 20 mm

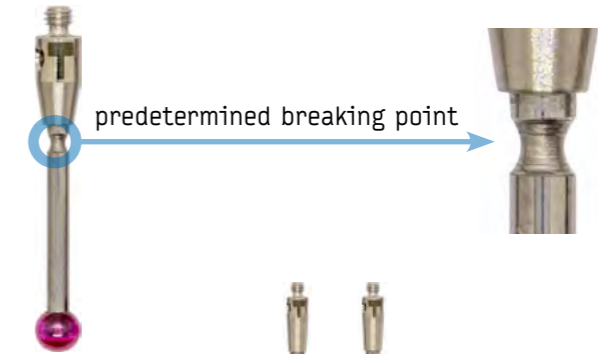

Art.no.: 0014ST210 - Ø2 x 10 mm
Art.no.: 0014ST220 - Ø2 x 20 mm
Art.no.: 0014ST230 - Ø2 x 30 mm

Art.no.: 0014ST420 - Ø4 x 20 mm
Art.no.: 0014ST430 - Ø4 x 30 mm

Order data:

Article no.	Description
0014WP110	Probing system workpiece probe WP110 (incl. receiver RC100)
0014TP100	Probing system tool probe TP100 (incl. receiver RC100)
0014WTP01	Complete system (workpiece/tool probe WP110/TP100) (incl. receiver RC100)
0014WP200	Probing system workpiece probe WP200 (incl. receiver RC100)
0014TP125	Probing system tool probe TP125 (incl. receiver RC100)
0014WTP02	Complete system (workpiece/tool probe WP200/TP125) (incl. RC100)
0014TP135	Tool probe TP135 (cable connection)
0014ST210	Stylus Ø2x10 (M2)
0014ST220	Stylus Ø2x20 (M2)
0014ST230	Stylus Ø2x30 (M2)
0014ST320	Stylus Ø3x20 (M2)
0014ST420	Stylus Ø4x20 (M2)
0014ST430	Stylus Ø4x30 (M2)
0014KH100	Calibration aid KH100 Ø20 x 100 mm
0014PW070	Pos. station PW070
0014PW100	Pos. station with airblow for TP100
0014PW125	Pos. station with airblow for TP125



Your sales contact



Maik Schoch



+49 7181 606986 7
@ maik.schoch@tschorn-gmbh.de



Sina Kortmann



+49 7181 606986 7
@ sina.kortmann@tschorn-gmbh.de

Repair service



Crashed?

All our devices can be repaired.

Our worldwide resellers support you for any repair or service question.



3D Testers

3D Digital

3D Digital

Revolutionary: Digital & Analogue on one display!

Analogue display
Rough scale

Analogue display
Fine scale 0,01 mm
from -0,250

Digitale Anzeige
Auflösung 0,005 mm

Probing status LED
Off = Rough scale
Green = Fine scale
Red = Warning range



Revolutionary! The new **3D Tester Digital** combines the best of two worlds, as the 3D Tester Digital is digital and analogue at the same time: The digital display with numbers allows you to accurately read digitally. Tracking a rapidly changing digital display with your eyes is nearly impossible. Since it is difficult for your eye to follow a rapidly changing digital display with certainty, the additional analog display of the 3D Tester Digital gives you security when reading. Because a moving pointer can be followed visually much better and more reliably. Additionally, a built-in LED shows the status of your probing with the help of different colours and protects you from overpassing and a possible resulting defect. With the 3D Tester Digital, you quickly and easily determine workpiece zero points and lengths in all axial directions (X/Y/Z) and you can adjust your workpiece or vice to the machine axis.

How to work with the 3D Tester Digital:

Clamp the 3D Tester into your tool holder, adjust the run-out and there you go:



Rough scale (1.5 till 0,25 mm)

Fast approach and safe probing thanks to the analogue rough display. The eye can easily follow the progress as the black bar decreases clockwise.



Fine scale (0,25 till 0 mm)

At -0,250 mm, the display changes to the fine scale and the green LED lights up.



Zero point (precisely reached)

When the „0“ is reached, the spindle axis is positioned precisely on the edge of the workpiece.



Danger of crash (0 mm till ERR01)

When overpassing, the LED warns in red and the black bar builds up clockwise to the right. Shortly before crash (>1 mm), you can see ERR01 on the display.



Of course, the 3D Tester Digital is small and slim, waterproof (IP67) and is delivered with a serial number and a test certificate. The scope of delivery also includes a CR2450 battery and a ceramic probe tip Ø3. Both items are available as spare parts. Switch on the 3D Tester Digital by moving the probe tip in any direction X, Y or Z. If not used, the probe switches off after 2 minutes.

3D Digital



Revolutionary: Digital & Analogue on one display!



Delivery starts in January 2023

Article no.	Description	Shank	Ball
001D30012	3D Digital	Ø12	Ø3
001D32450	Spare battery CR2450		



You can find spare parts on page 26.

Slim. robust. waterproof. With Tschorn 3D Testers you quickly and easily determine workpiece zero points and length measurements or adjust your workpiece or vice parallel to your machine axis.

3D stands for three-dimensional probing in all axial directions (X/Y/Z) - and all of this is possible with the same indicator resolution.
V2 stands for the newest generation of our 3D Testers.
A seal protects the 3D Tester from oil and coolant (IP67).

3D Tester

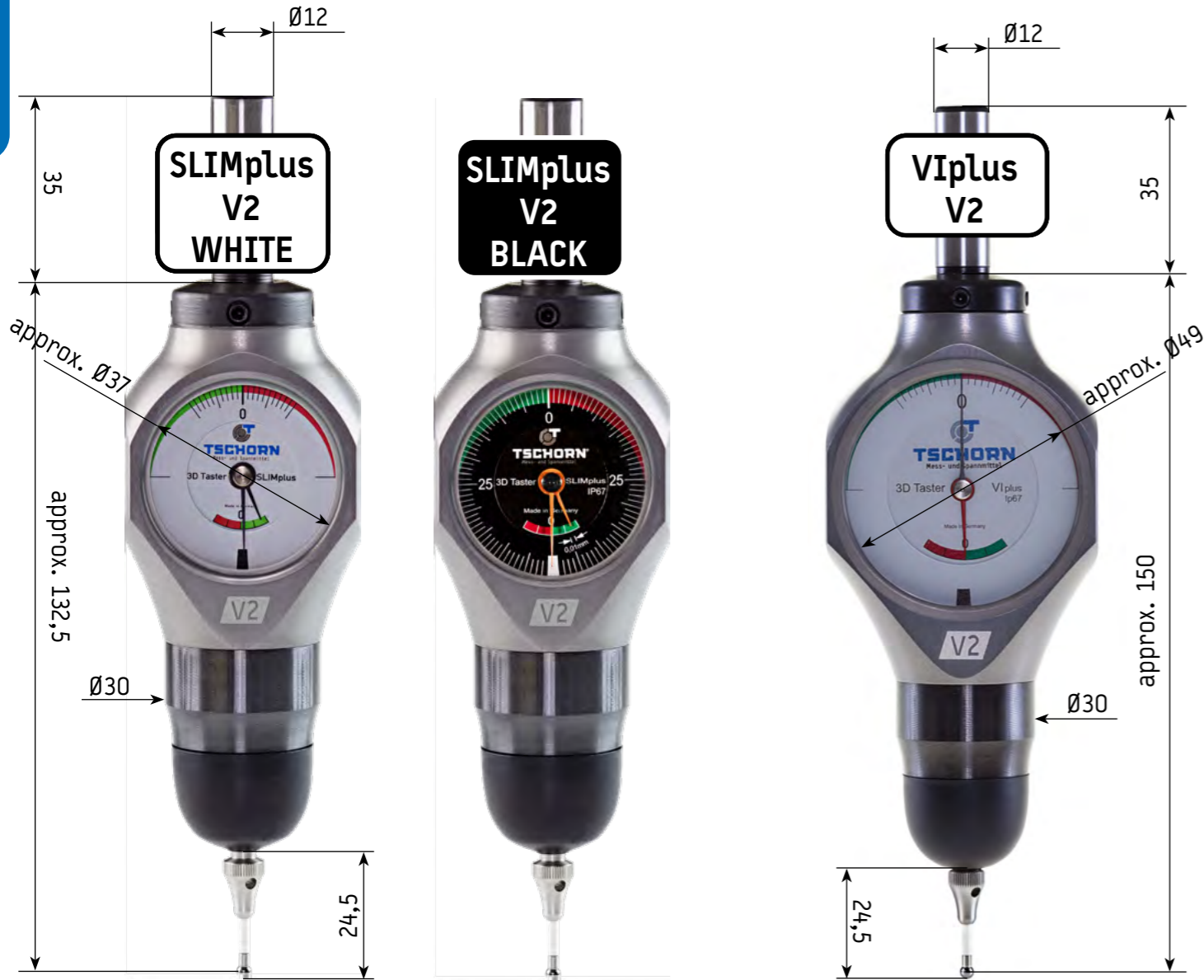

The universal device, the bestseller

Identical to SLIMplus WHITE but easier to read because of the black dial face

Especially on big machines easier to read but nevertheless slim built



3D Tester

How to work with the 3D Tester:

Clamp the 3D Tester into your tool holder.
Adjust the run-out as explained in the manual.
Approach your workpiece with the 3D Tester.
As soon as the indicators show „0“, the spindle axis precisely stands on the workpiece edge.

Crashed? Contact your reseller for service!

Delivery contains:

3D Tester with serial number, incl. probe tip ceramic Ø3, adjusting key, with factory certificate

Article No.	Description	Shank	Length	Tester
001V2D012*	3D Tester SLIMplus V2 WHITE	Ø12	approx. 132,5 mm	Ø3
001V2DB12*	3D Tester SLIMplus V2 BLACK	Ø12	approx. 132,5 mm	Ø3
001V2DA40	3D Tester SLIMplus V2 WHITE with shank DIN69871 A40	DIN69871 A40	approx. 132,5 mm	Ø3
001V2V012	3D Tester VIplus V2	Ø12	approx. 150,0 mm	Ø3

*also available with shank Ø8 and Ø10 as special construction.

You can find spare parts on page 26.



The special probe tip Ø56:

Depth extreme!



Video



Advantages:

- probing extremely depth
- also parallel running

Because its diameter is bigger than the body of the 3D Tester this probe tip allows probing in almost endless depth and opens up new possibilities. When using slim tool holders to clamp the 3D Tester (diameter smaller than 50 mm), you can extend the depth of probing as deep as you want. Find your workpiece position and check parallelism in almost endless depth.



Article No.	Description	Length	Tester
00163D056	Probe tip Ø56 for 3D Tester SLIMplus	62	Ø56

SAVEplus

The 3D Tester SAVEplus is also characterized by its slim design - however, it is the cost-effective variant among our 3D Tester models.

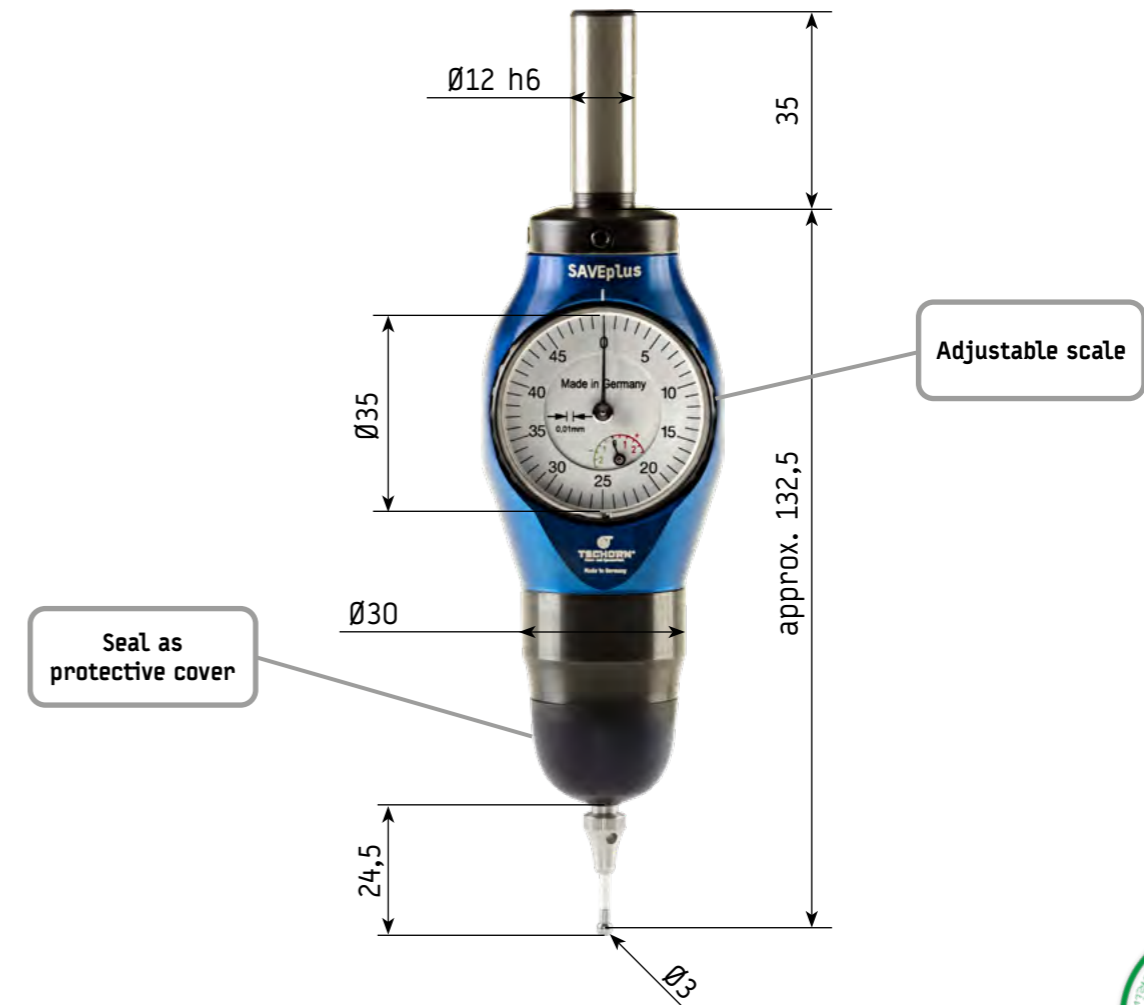

Delivery contains:

3D Tester incl. probe tip ceramic Ø3

Article No.	Description	Shank	Length	Tester
00163B012	3D Tester SAVEplus	Ø12	approx. 134 mm	Ø3



Crashed? Contact your reseller for service!



Spare parts

The spare parts can be used for our 3D Tester models.



Easy screwing in and unscrewing of the probe tip thanks to the practical borehole.

Two hexagon keys size 2 are supplied with each 3D Tester SLIMplus, VIplus and DREHplus.

Article No.	Description	Length	Tester
00163C003	Probe tip ceramic	approx. 27 mm	Ø3
00163C006	Probe tip long ceramic	approx. 62 mm	Ø6
00163D099	Seal for 3D Tester	-	-



Important Note:

When changing the probe tip, make sure not to damage the seal (see picture 1.), and check the run-out each time after changing the probe tip (see picture 2.). You will find a detailed description in the operating instructions.



Videos for training



3D Tester: Scope of delivery



3D Tester: Run-out



3D Tester: Probing



Repair service



Crashed?

All our 3D-Testers can be repaired.

Our worldwide resellers support you for any repair or service question.



The plus for your lathe!

Tool measurement in all axes also in the rotating center (Y)

Innovative probing technology

The conical probing corpus allows you to measure any possible cutting insert with various radii and / or angles at any point of the probing corpus. You probe until both indicators show „0“. In this position, the outline of the conical probing corpus is exactly on the symmetry axis.

No other measuring equipment gives you the possibility to measure the rotating centre so simply, precisely and directly in your lathe.

Y=0 corresponds to the rotating centre. As a result, you ensure the best possible processing, achieve long lifetime and preserve best surfaces.



Y axis
Here you see Y=0

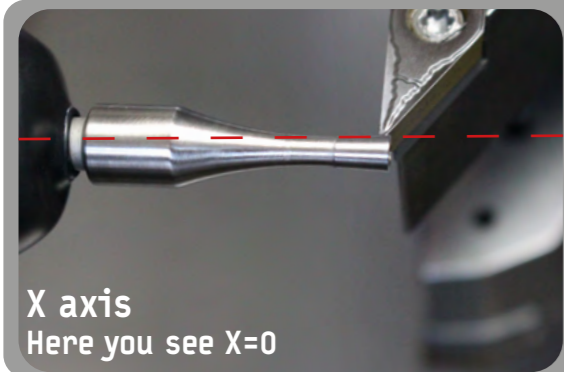

X axis
Here you see X=0

Without any further calculation, you measure your tools to the centre of the spindle, respectively X=0.

Also in Z, you can measure all tools, taking into account the length offset in your machine.

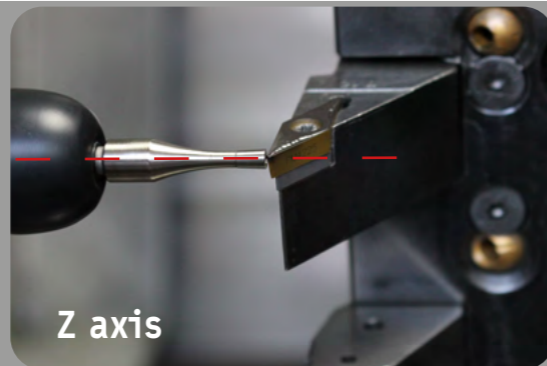

Z axis

Measure your tools in all axes - especially in Y

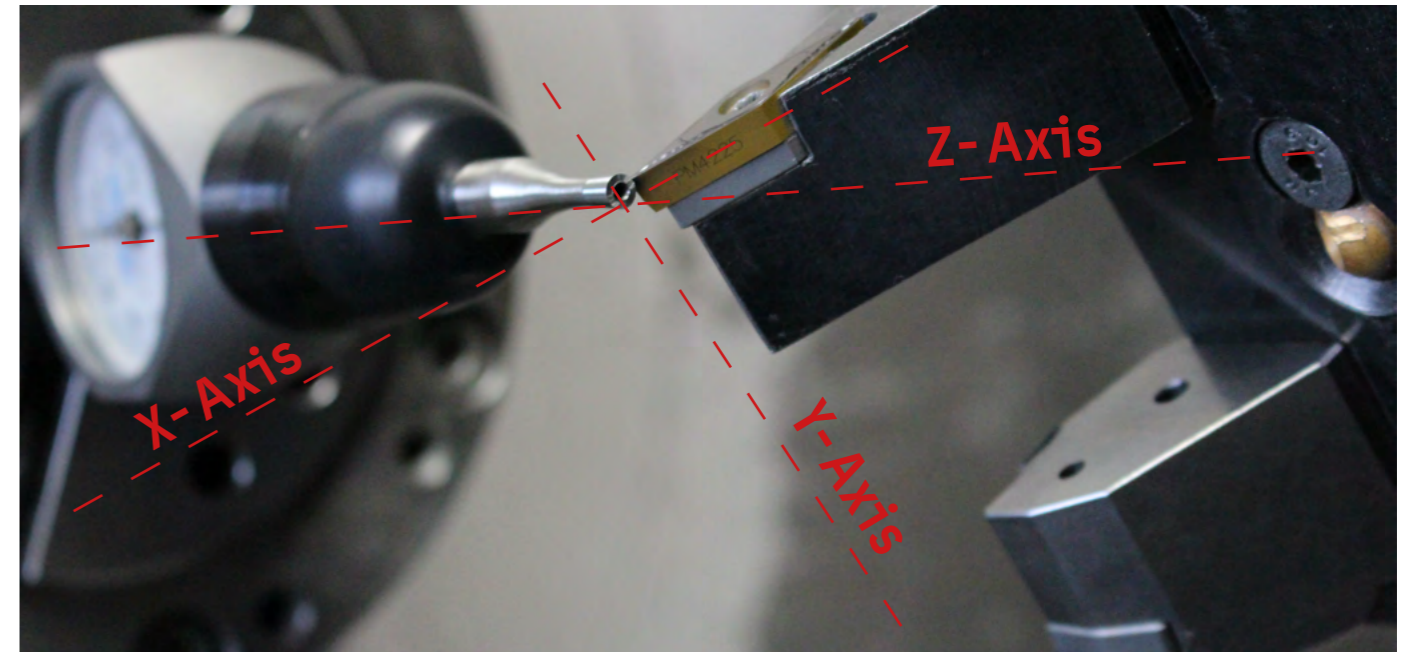

No other measuring equipment gives you the possibility to measure your tool to the rotating centre simply, precisely and directly in your lathe. This is made possible by our unique probing technology which we have developed specifically for the use in your lathe.

On a ball, it is impossible to precisely measure sharp turning tools. This is why the 3D Tester DREHplus has a patented conical probing corpus. With this, you directly probe the centre of the spindle, both in X axis and in Y axis.

No need for further calculations, since X = 0 and Y = 0.

 Crashed? Contact your reseller for repair service!



Delivery contains:

3D Tester incl. probe tip DREHplus, adjusting key, with factory certificate

Article No.	Description	Shank	Length	Tester
001V2T020	3D Tester V2 DREHplus V2	Ø20	approx. 138 mm	Ø3,6/Ø3,2
00163T036	Probe tip DREHplus	-	approx. 34 mm	Ø3,6/Ø3,2

Your sales contact



Maik Schoch



+49 7181 606986 7
@ maik.schoch@tschorn-gmbh.de



Sina Kortmann



+49 7181 606986 7
@ sina.kortmann@tschorn-gmbh.de

Repair service



Crashed?

All our devices can be repaired.

Our worldwide resellers support you for any repair or service question.



Edge finders optical

Edge finders optical



Edge finders 3D
Developed by us.
Produced only by us.

Functionality:
If a conductive workpiece and the probing ball touch (within the axis X, Y and Z), the electrical circuit gets closed and a LED signal appears.

When the LED signal appears, the workpiece's edge is reached with a distance of 5 mm (= radius of probing ball Ø10).

In Z axis, the reference length has to be measured and taken into account respectively.

Probing X/Y axis

Probing X/Y axis

Pass over

Probing Z axis

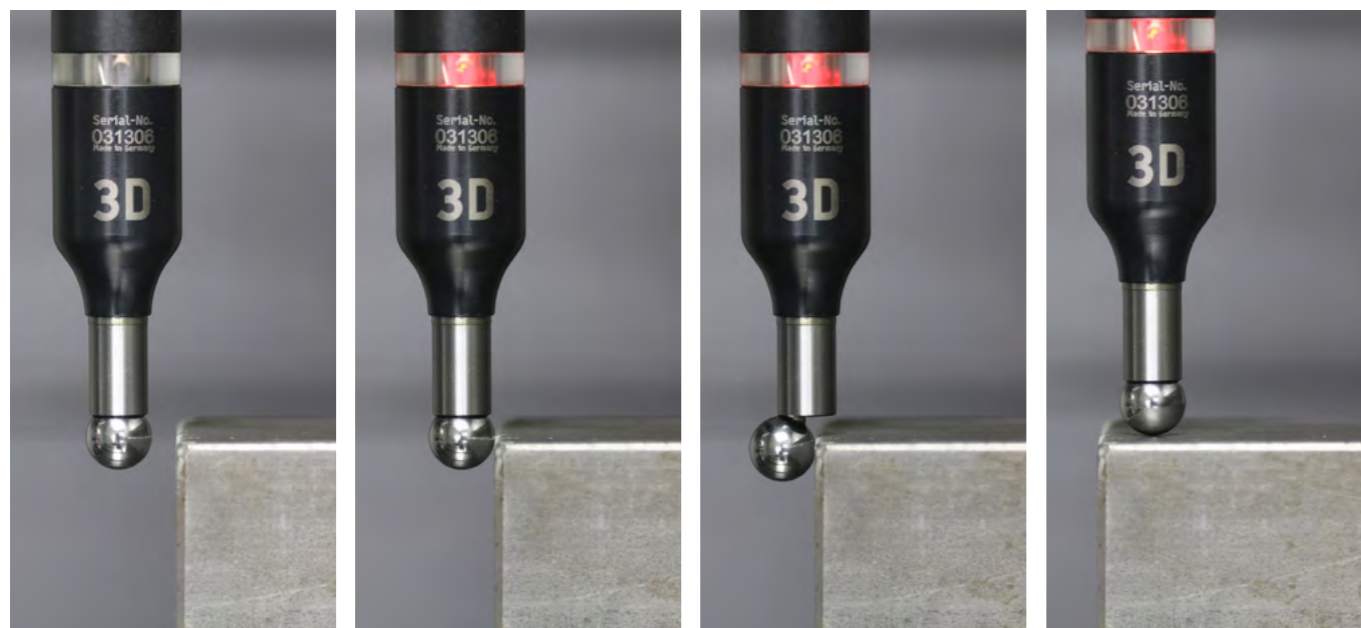

Probing accuracy <= 0.010 mm !

3D version:
Probing in X, Y and Z !



Application:

For accurate zero point determination and bore centers to the spindle with an accuracy of probing smaller than 0.010 mm.

Please note:

Protection against humidity is essential for the edge finder due to the built-in electronic components.

Delivery includes:

Edge finder with serial number and test certificate in a plastic case.

Article No.	Description	Shank	Length	Probing ball	Battery
001031200	Edge finder 3D	Ø12	approx. 111	Ø10	12V-Type 27A
001031600	Edge finder 3D	Ø16	approx. 111	Ø10	12V-Type 23A
001032000	Edge finder 3D	Ø20	approx. 106	Ø10	12V-Type 23A
001032500	Edge finder 3D	Ø25	approx. 116	Ø10	12V-Type 23A

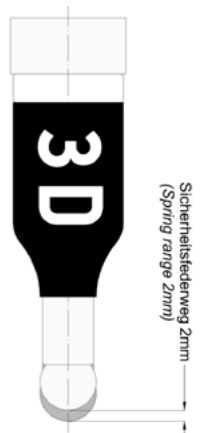

Edge finders optical 3D in wooden case

Article No.	Description	Shank	Length	Probing ball	Battery
001031299	Edge finder 3D	Ø12	approx. 111	Ø10	12V-Type 27A
001031699	Edge finder 3D	Ø16	approx. 111	Ø10	12V-Type 23A
001032099	Edge finder 3D	Ø20	approx. 106	Ø10	12V-Type 23A
001032599	Edge finder 3D	Ø25	approx. 116	Ø10	12V-Type 23A



3D Precision probe

Probing accuracy ≤ 0.005 mm

3D version:
Probing in X, Y and Z

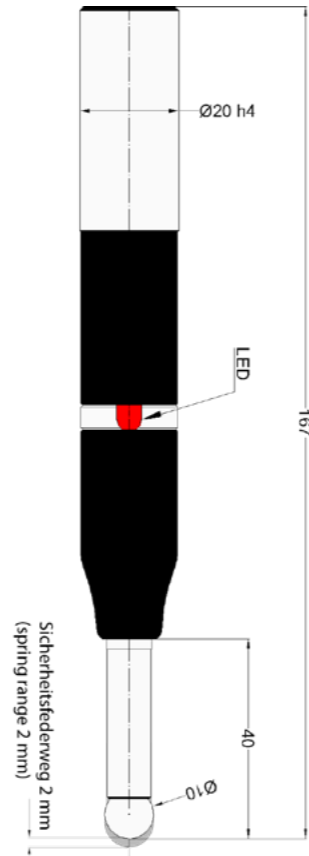

Application:

Our 3D precision probe is a highly precise measuring device which gives out highly precise three dimensional probing results on metal-cutting machines.

Accuracy:

Within all three axis, the accuracy of probing is smaller than 0.005 μ m.

Please note:

Protection against humidity is essential for the edge finder due to the built-in electronic components.

Delivery includes:

3D precision probe with serial number and test certificate in a plastic case (for clean storage).

Article no.	Description	Shank	Length	Probing ball	Battery
001532000	3D precision probe	Ø20	approx. 167	Ø10	12V-Typ 23A

Edge finders optical & acoustic

Probing accuracy ≤ 0.010 mm

3D version:
Probing in X, Y and Z

2D version:
Probing in X and Y



Application:

For accurate zero point determination and bore centers to the spindle with an accuracy of probing smaller than 0.010 mm. When you reach the position, you hear an additional acoustic signal.

Please note:

Protection against humidity is essential for the edge finder due to the built-in electronic components.

Delivery includes:

Edge finder with serial number and test certificate in a plastic case.

Article no	Description	Shank	Length	Probing ball	Battery
001122000	Edge finder optical + acoustic 2D	Ø20	approx. 119	Ø10	12V-Typ 23A
001132000	Edge finder optical + acoustic 3D	Ø20	approx. 131	Ø10	12V-Typ 23A

3D Precision probe

Edge Find. opt. & acoust.

Edge finder optical 2D

Edge finders optical



Probing accuracy ≤ 0.010 mm !

2D version:
Probing in X and Y !

Application:

For accurate zero point determination and bore centers to the spindle with an accuracy of probing smaller than 0.010 mm.

Please note:

Protection against humidity is essential for the edge finder due to the built-in electrical components.

Delivery includes:

Edge finder with serial number and test certificate in a plastic case.

Article No.	Description	Shank	Length	Probing ball	Battery
001021200	Edge finder 2D	Ø12	approx. 99	Ø10	12V-Type 27A
001021600	Edge finder 2D	Ø16	approx. 99	Ø10	12V-Type 23A
001022000	Edge finder 2D	Ø20	approx. 94	Ø10	12V-Type 23A
001022500	Edge finder 2D	Ø25	approx. 104	Ø10	12V-Type 23A
00102M200	Edge finder 2D	MK2	approx. 133	Ø10	12V-Type 27A

Edge finder optical 2D in wooden case

Article No.	Description	Shank	Length	Probing ball	Battery
001021299	Edge finder 2D	Ø12	approx. 99	Ø10	12V-Type 27A
001021699	Edge finder 2D	Ø16	approx. 99	Ø10	12V-Type 23A
001022099	Edge finder 2D	Ø20	approx. 94	Ø10	12V-Type 23A
001022599	Edge finder 2D	Ø25	approx. 104	Ø10	12V-Type 23A



Edge finder optical 2D Eco

TSCHORN^{ECO}

The cost-effective version of our optical 2D edge finder: without serial number, without factory certificate - but Made in Germany

Article No.	Description	Shank	Length	Probing ball	Battery
0010216EP	Edge finder 2D	Ø16	approx. 99	Ø10	12V-Type 23A
0010220EP	Edge finder 2D	Ø20	approx. 94	Ø10	12V-Type 23A



Edge finders optical



Crashed? Contact your reseller for repair service!

Spare parts for optical edge finders

Article No.	Description	Volt
0011Z6000	Spare battery 23A	12V
0012Z6000	Spare battery 27A	12V



Edge finder gun-drilling

Quick and precise determination of the workpiece position on gun-drilling machines

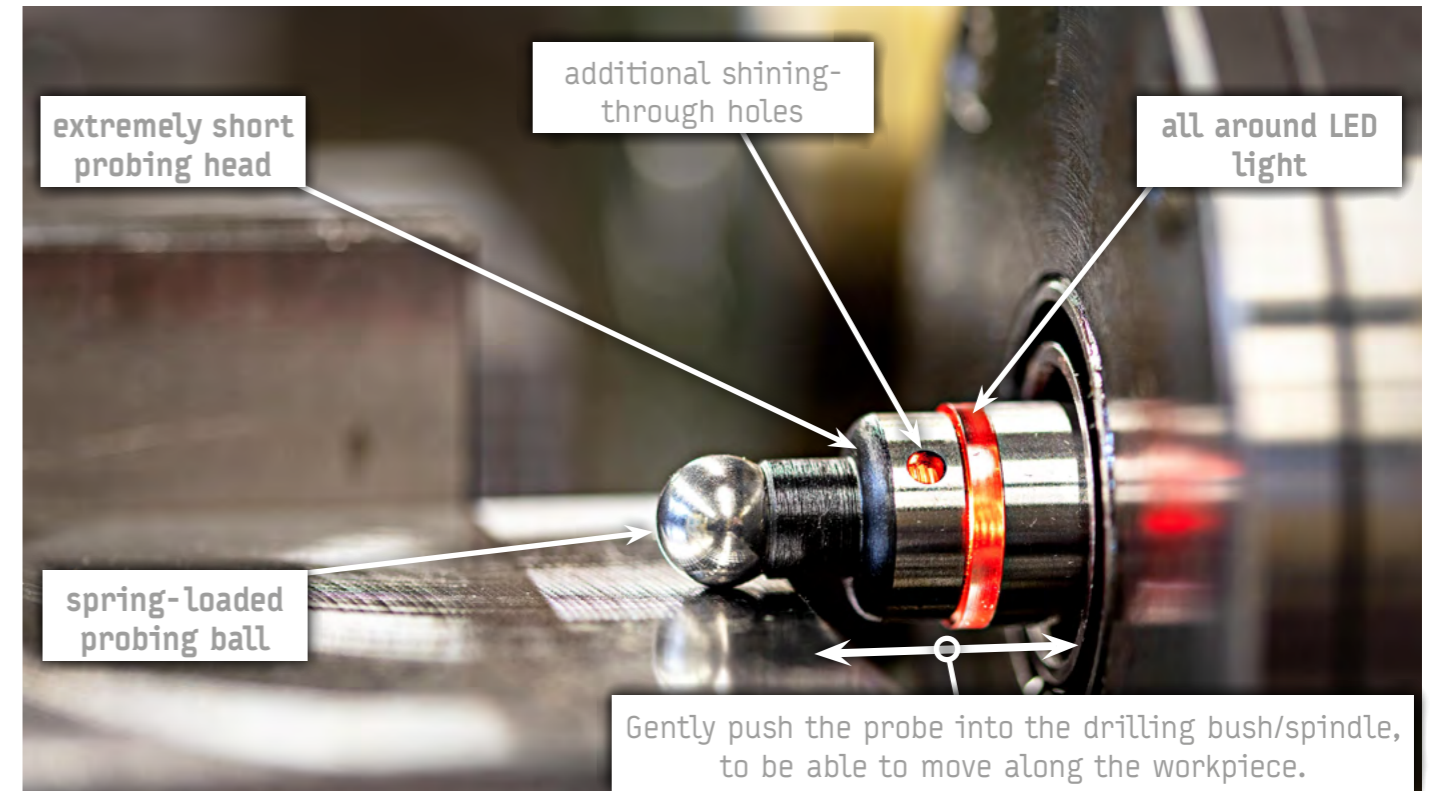
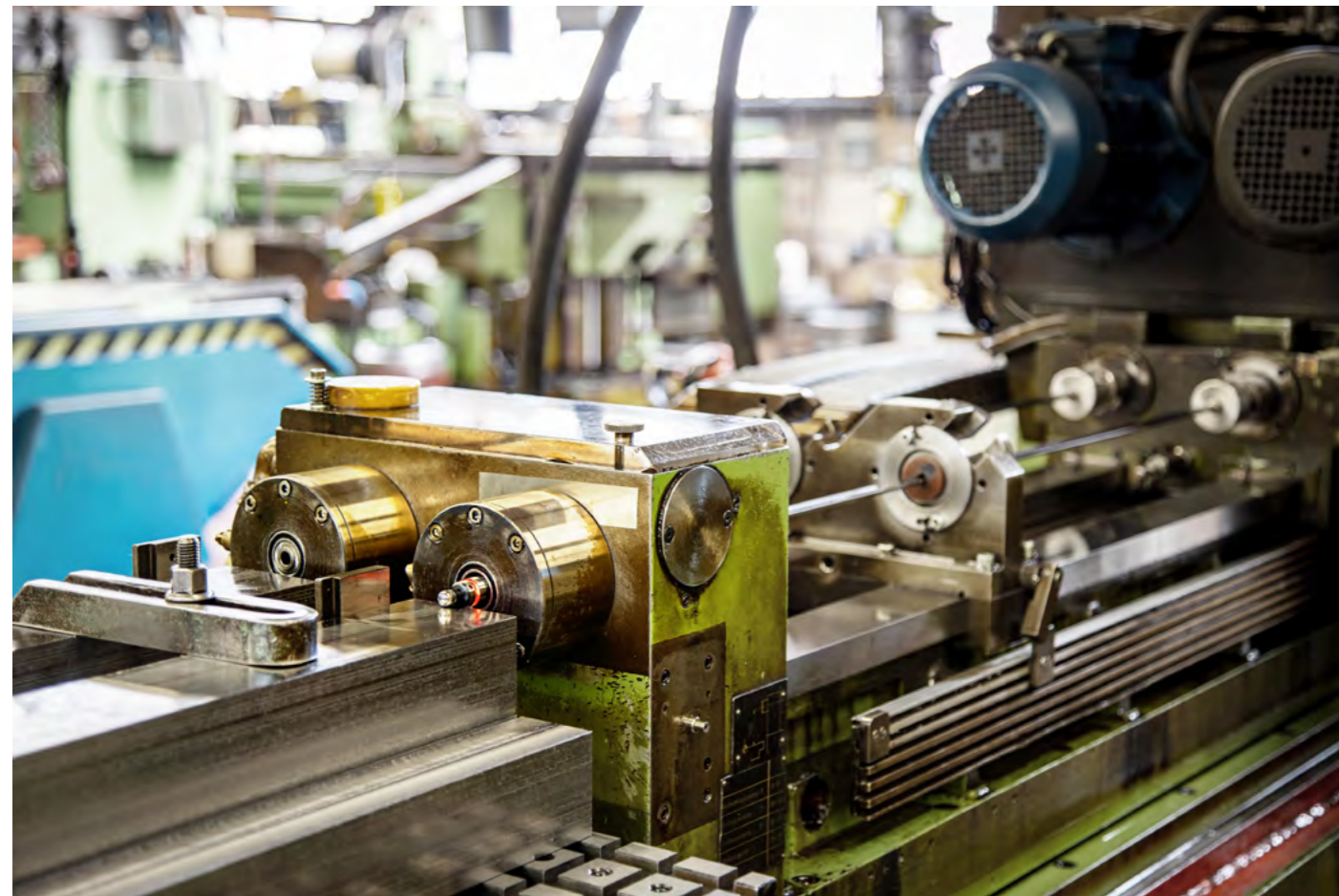
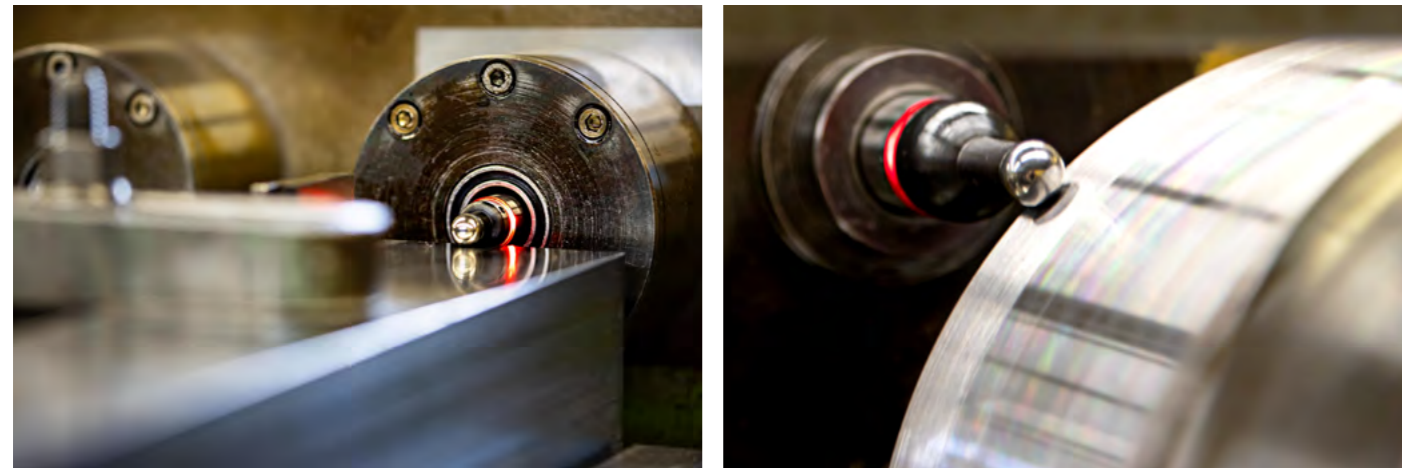

Innovative construction:

The shank and the probe head have been optimized for the use on gun-drilling machines. The construction has been optimized in a way that the edge finder can be pushed gently into the drilling bush/spindle. That's why the edge finder can be moved past the workpiece even if the distance between the drilling bush and the workpiece is extremely small.

Optical LED probing signal:

Thanks to additional shining-through holes and the all around LED light, the LED probing signal can always be seen easily and clearly, even when the distance between the drilling bush and the workpiece is very close.

Operating mode:

The red LED of the edge finder lights up as soon as the ball touches an electrical conductive workpiece. This reduces the time required to determine the workpiece position to a minimum compared to the conventional method.

Built-in security:

The probing ball is spring-mounted in the edge finder. This ensures protection from overrunning in X and Y.



Wide application range: chose between two shank diameters Ø18 and Ø25.
The edge finder for gun-drilling is clamped directly at the shank in the drilling bush/spindle.

Edge finder gun-drilling

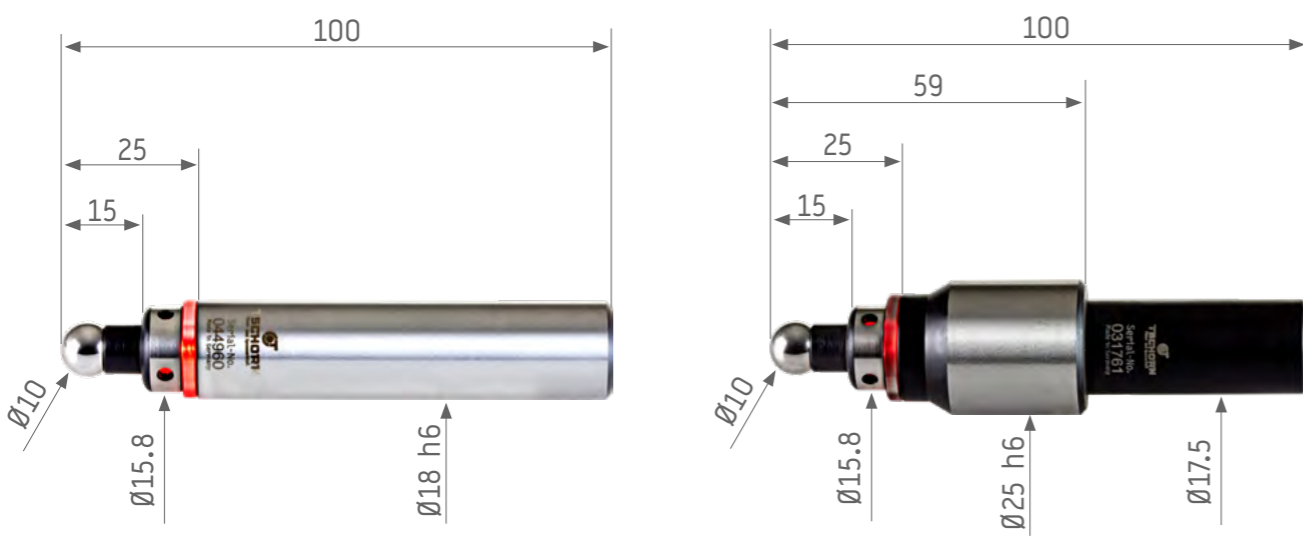

Article No.	Description	Shank	Probing ball
001821800	Edge finder gun-drilling 2D - shank Ø18	Ø18	Ø10
001822500	Edge finder gun-drilling 2D - shank Ø25	Ø25	Ø10
0011Z6000	Spare battery 23A		

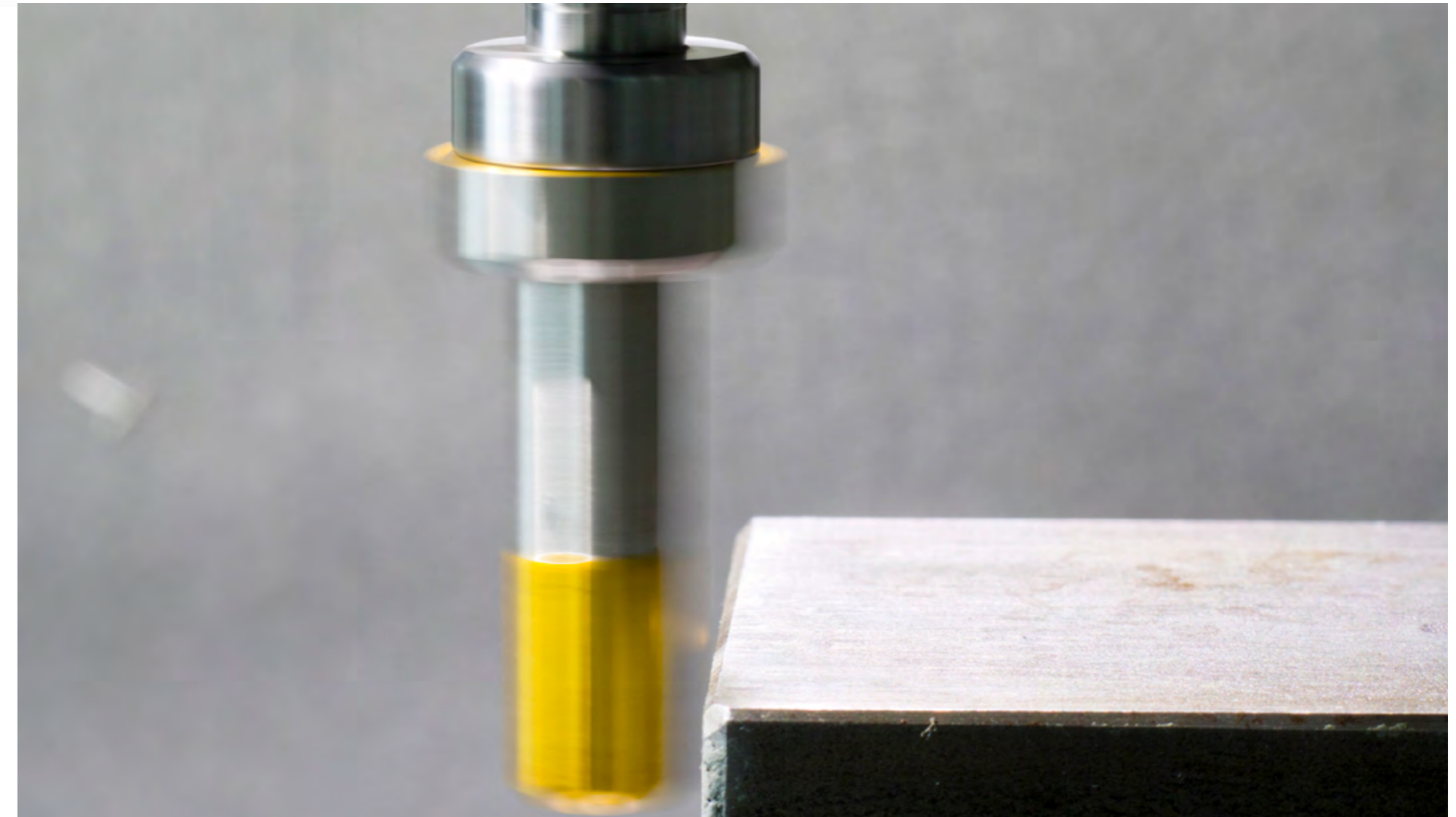

Edge finders mech.

 Crashed? Contact your reseller for service!



The origin of all testers!

To approach reference surfaces or edges with a highly precise repeatability. We deliver all standard version edge finders with probe head Ø6 mm, Ø10 mm as well as the popular probe head Ø10/4 mm. Shanks are available with Ø6 mm, Ø10 mm and also Ø8 mm.

Special versions are our TIN edge finders. These are made out of antimagnetical stainless steel and are coated with a wear-resistant TIN layer.

We deliver all our edge finders in an environmentally friendly cardboard packaging. We also offer a wooden case for storage.



Edge finders mech.

Edge finders mech.



1. The edge finder body can be tilted out from the axis' centre by a gentle tip of the finger and is out-of-the-round.



2. By slowly and carefully approaching the rotating edge finder to the respective reference surface, the oscillation movement steadies successively.



3. When reaching the final position, the edge finder body passes along the edge. Now, the position corresponds to the radius of the tracer.



001001000

001010400

001081000

001081400

001000600

Edge finders mechanical



Standard version:

(Made in India)

The standard version is manufactured by our long-term supplier in India according to our quality standards. Here in Germany, we check the edge finders in details in our quality laboratory so that we can guarantee the unique quality of our edge finders.

Article No.	Description	Shank	Tester
001000600	Edge finder mech.	Ø6	Ø6
001001000	Edge finder mech.	Ø10	Ø10
001010400	Edge finder mech.	Ø10	Ø10 / Ø4
001081000	Edge finder mech.	Ø8 (Ø10)	Ø10
001081400	Edge finder mech.	Ø8 (Ø10)	Ø10
001000699	Edge finder (in wooden case)	Ø6	Ø6
001001099	Edge finder (in wooden case)	Ø10	Ø10
001010499	Edge finder (in wooden case)	Ø10	Ø10 / Ø4
001081099	Edge finder (in wooden case)	Ø8 (Ø10)	Ø10
001081499	Edge finder (in wooden case)	Ø8 (Ø10)	Ø10 / Ø4



Edge finders TIN

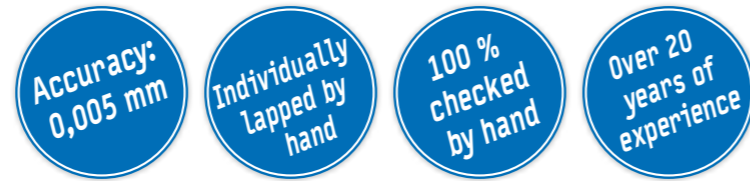

TIN version:

(Made in Germany)

The TIN version is **antimagnetical** and the probe head is made out of stainless steel. The probe head is covered with a wear-resistant TIN layer.

Article No.	Description	Shank	Tester
001TIN010	Edge finder TIN	Ø10	Ø10
001TIN104	Edge finder TIN	Ø10	Ø10 - Ø4



Edge finders straight

Straight version without collar

(Made in India)



Artikel-Nr.	Description	Shank	Tester
001010000	Edge finder mech. Ø10 / Ø10 (straight)	Ø10	Ø10
001010600	Edge finder mech. Ø6-Ø10 / Ø10 (straight)	Ø10	Ø6 - Ø10



Edge finders ECO

TSCHORNECO

The cost-efficient version of our mechanical edge finders. (Made in India)



Article No.	Description	Shank	Tester
0010010EP	Edge finder mech.	Ø10	Ø10
0010104EP	Edge finder mech.	Ø10	Ø10 / Ø4



Spare springs



Article No.	Description	Shank	Tester
001Z01000	Spare spring Ø4,6 x 40 (package contains: 10 pcs.)	Ø10 / Ø8	Ø10 / Ø10-Ø4
001Z00600	Spare spring Ø2,6 x 25 (package contains: 10 pcs.)	Ø6	Ø6

Repair kit

Content:

- 1 - Cover
- 2 - Spring
- 3 - Pin
- 4 - Mounting paste

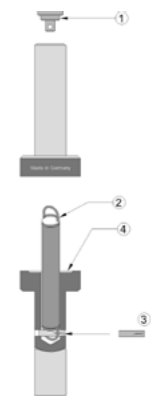

Article No.	Description	Shank	Tester
001K01000	Repair Kit	Ø10 / Ø8	Ø10 / Ø10-Ø4
001K00600	Repair Kit	Ø6	Ø6

Your sales contact



Maik Schoch



+49 7181 606986 7
@ maik.schoch@tschorn-gmbh.de



Sina Kortmann



+49 7181 606986 7
@ sina.kortmann@tschorn-gmbh.de

Repair service



Crashed?

All our devices can be repaired.

Our worldwide resellers support you for any repair or service question.



Zero setters

Zero setter Micro

Zero setters



Micro tools:

We even measured milling tools with $\varnothing 0,1$ mm without any problems.

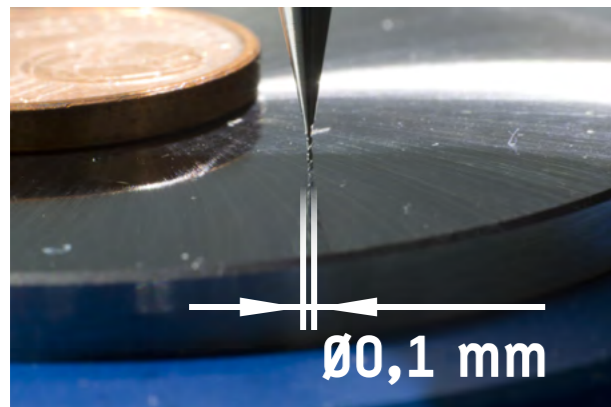

Simple adjustment:
Push tester
Small indicator at -2 mm
Turn scale for large indicator to 0
Ready!

Application:

To determine the position of workpiece surfaces or tool lengths in Z-direction at milling machines or lathes. The zero setter is placed on the workpiece. The spindle has to be moved carefully onto the tracer until the dial gauge indicates „0“. The reference dimension 100 mm to the workpiece has been reached. A safety spring deflection of max. 2 mm is included.

Type:

To allow lateral mounting, a zero setter with built-in magnets is also available.

Delivery includes:

Zero setter with serial number and test certificate.



Zero setters



Article No.	Description	Body	Tester
002400100	Zero setter Micro 100 mm without magnet	Ø54,5	Ø42
002402100	Zero setter Micro 100 mm with magnet	Ø54,5	Ø42
002UM0100	Spare dial gauge for zero setter Micro 100 mm		



Crashed? Contact your reseller for repair service!

Zero setter mechanical

Zero setters

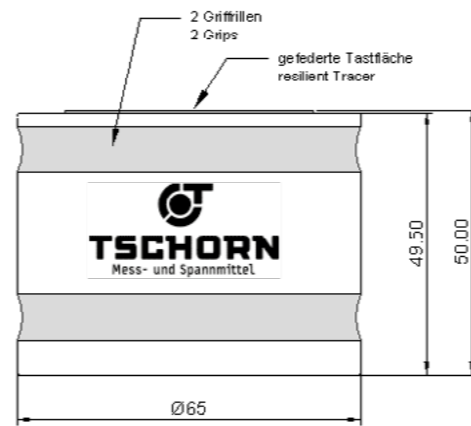

Application:

To determine the position of workpiece surfaces or tool lengths in Z-direction at milling machines or turning lathes. The zero setter is placed on the workpiece. The spindle has to be moved carefully onto the tracer until the dial gauge indicates „0“. The reference dimension 50 mm to the workpiece has been reached. A safety spring deflection of max. 2 mm is included.

Type:

To allow lateral mounting, a zero setter with built-in magnets is also available.

Delivery includes:

Zero setter with serial number and test certificate.

Article No.	Description	Body	Tester
002101000	Zero setter 50 mm without magnet	Ø65	Ø47
002102000	Zero setter 50 mm with magnet	Ø65	Ø47



Zero setter mechanical Eco

TSCHORNECO

The cost-efficient version of our mechanical zero setters: without serial number, without factory certificate - but Made in Germany



Zero setters

Article No.	Description	Body	Tester
0021010EP	Zero setter ECO 50 mm	Ø39	Ø20
0021020EP	Zero setter ECO 50 mm with magnet	Ø39	Ø20



Crashed? Contact your reseller for repair service!

Spare parts for mechanical zero setters

Article No.	Description	Body	Reading
002U01000	Spare dial gauge	Ø40	0,01 mm



Zero setter optical

Quick length measurement when turning and milling.

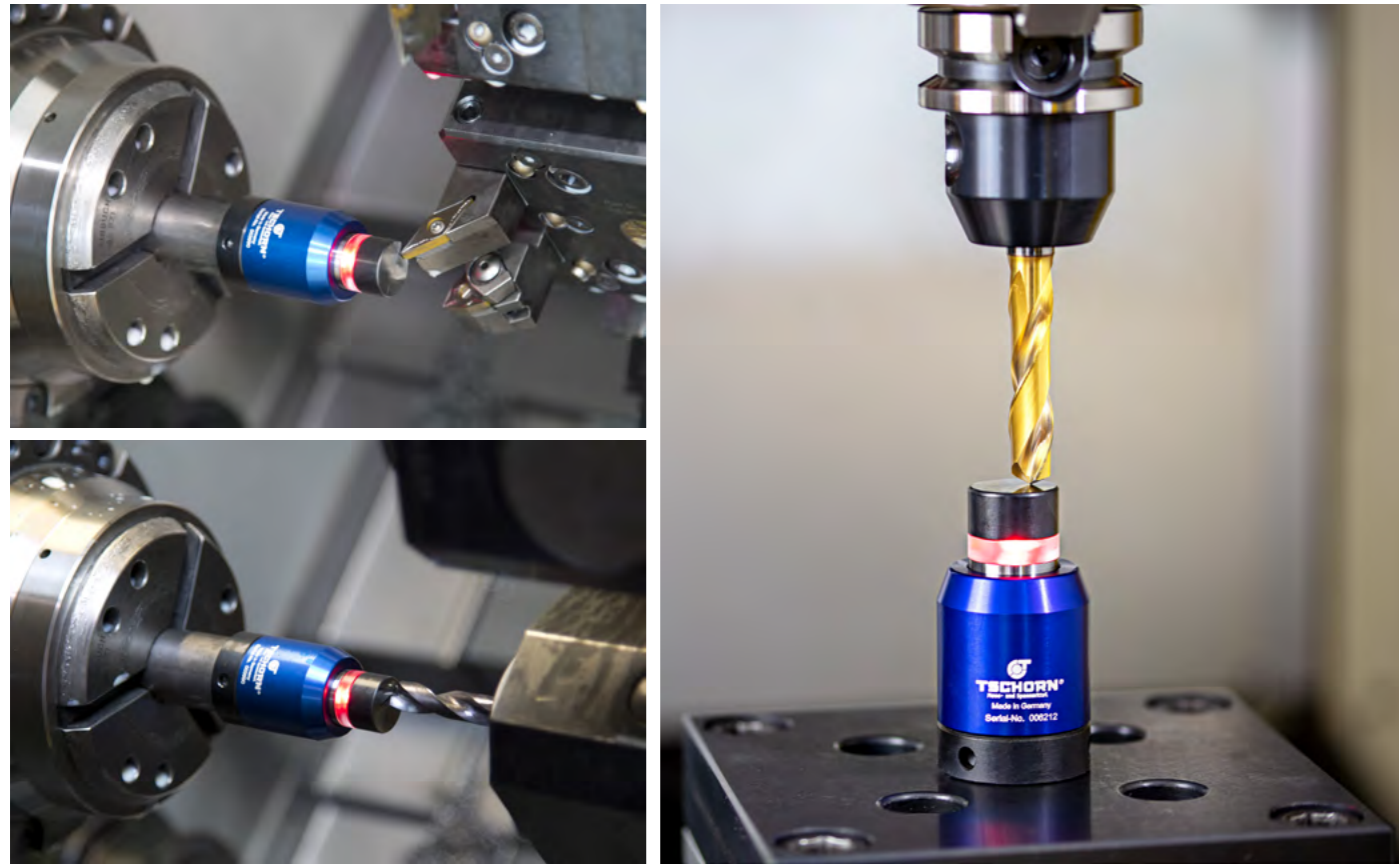

Application on the lathe thought-out in detail

Secure horizontal grip
already at Ø8
thanks to 3 powerful magnets

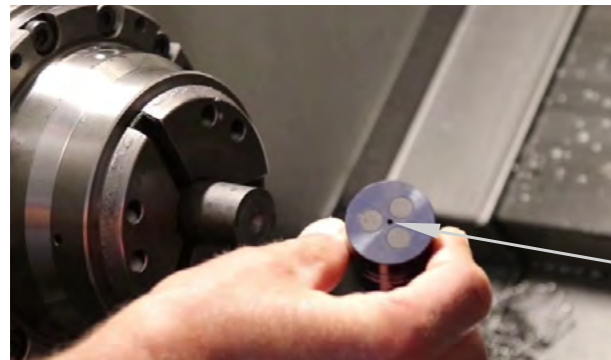

Tolerance for the turning scrap,
avoids measuring faults

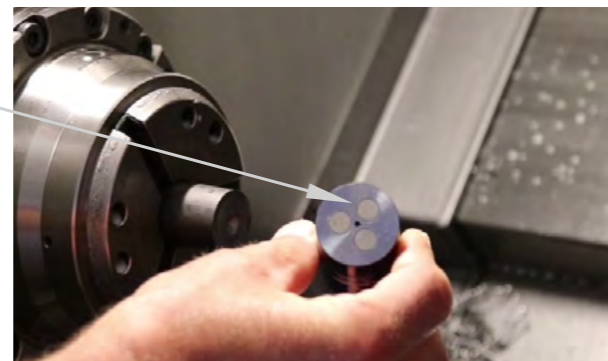

Application:

To determine the position of workpiece surfaces or tool lengths in Z-direction at milling machines or lathes. The zero setter is placed on the workpiece. The spindle has to be moved carefully onto the tracer until the dial gauge indicates „0“. The reference dimension 60 mm to the workpiece has been reached. A safety spring deflection of max. 2 mm is included.

Type:

To allow lateral mounting, a zero setter with built-in magnets is also available.

Delivery includes:

Zero setter with serial number and test certificat.

Article No.	Description	Body	Tester
002060100	Zero setter optical 60 mm without magnet	Ø32	Ø19
002060200	Zero setter optical 60 mm with magnet	Ø32	Ø19
0013Z4400	Spare battery SR44		



Crashed? Contact your reseller for repair service!

Your sales contact



Maik Schoch



+49 7181 606986 7
@ maik.schoch@tschorn-gmbh.de



Sina Kortmann



+49 7181 606986 7
@ sina.kortmann@tschorn-gmbh.de

Repair service



Crashed?

All our devices can be repaired.

Our worldwide resellers support you for any repair or service question.



5D workpiece stopper

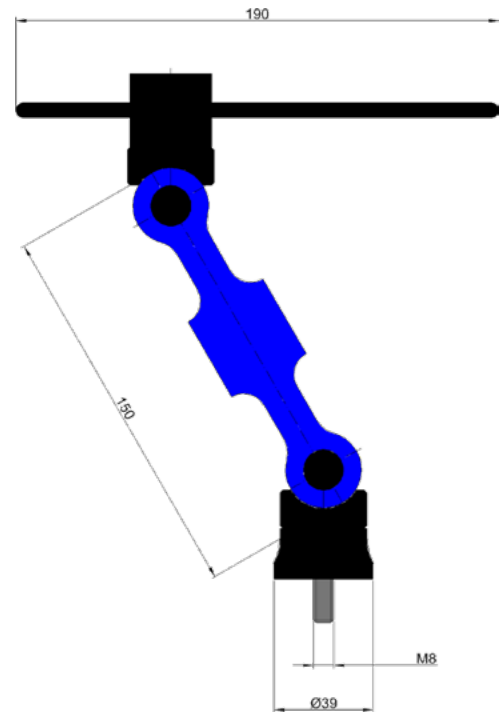

Combination element
to extend or to
combine two stoppers



Application:

One of the various application of the workpiece stopper is as a versatile instrument for the positioning on processing machines or during assembly.

Delivery includes:

Workpiece stopper with slide block M8x12.

Article No.	Description	Size
003420150	5D workpiece stopper	150
003400Z01	Combination element	
002080028	Slide block	M8 x 10
002140301	Slide block	M8 x 12
002140327	Slide block	M8 x 14
002153460	Slide block	M8 x 16
002153478	Slide block	M8 x 18

Slide block
10 - 18 mm

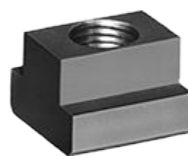

Workpiece stoppers with magnet



With its built-in magnets the workpiece stopper gets fixed directly to a bench vice (for example) and applies for exact positioning of your workpiece. After clamping, it can simply be removed and releases the positioning surface for processing.

The FlexiMag version is also equipped with a flexible rotate and swivel mechanism and makes it possible to position in a wide variety of places.



Article No.	Description	Shank	Holding force
003420001	FlexiMag - workpiece stopper	Ø30	200 N
003420002	EasyMag - workpiece stopper	Ø30	200 N



Your sales contact



Maik Schoch



☎ +49 7181 606986 7
 @ maik.schoch@tschorn-gmbh.de



Sina Kortmann



☎ +49 7181 606986 7
 @ sina.kortmann@tschorn-gmbh.de

Repair service



Crashed?

All our devices can be repaired.

Our worldwide resellers support you for any repair or service question.

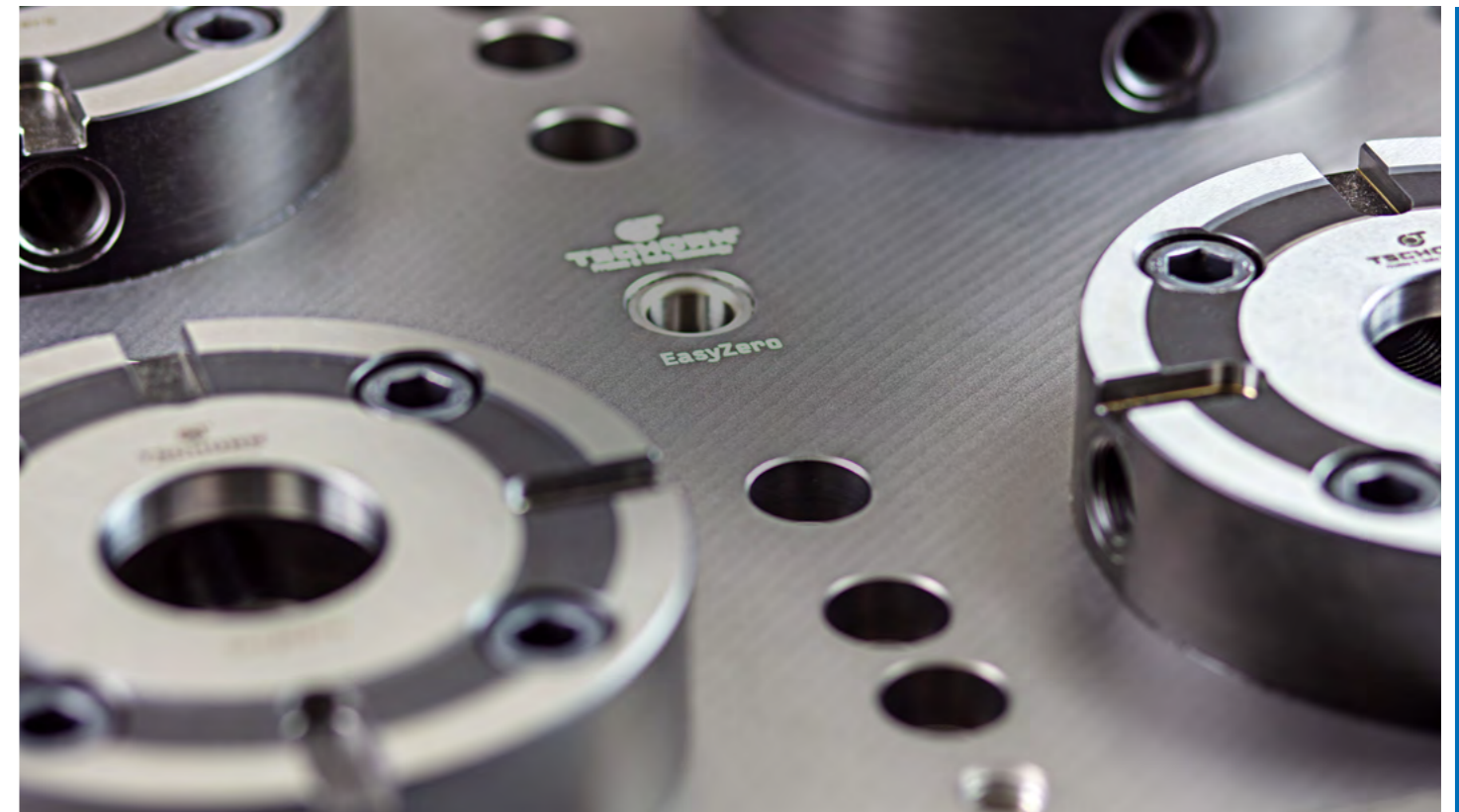

Clamping systems

Zero clamping system

Easy, independent, precise!
- exactly what you need!



Zero clamping system



Article-No.	Description	A	B	H
003501001	EasyZero Zero point system 1 pot	Ø130	-	32
003502001	EasyZero Zero point system 1 pot	Ø130	-	72
003503001	EasyZero Zero point system 1 pot	Ø147	-	125
003504001	EasyZero Zero point system 1 pot	140	175	72
003501002	EasyZero Zero point system 2 pots	340	175	72
003501004	EasyZero Zero point system 4 pots	340	375	72
003511001	EasyZero Adapter plate 1 clamping point	180	180	26
003511002	EasyZero Adapter plate 2 clamping points	346	156	26
003511004	EasyZero Adapter plate 4 clamping points	346	346	26
003521001	EasyZero Positioning stud			
003521002	EasyZero Orienting stud			
003521003	EasyZero Clamping stud			
003521011	EasyZero Cover stud			
003521012	EasyZero Cover for boreholes (package: 5 pcs)			
003521021	EasyZero Clamping screw			
003521031	EasyZero Positioning segment 8 mm (for indexing in the indexing slot)			
003521032	EasyZero Adapter sleeve M12-M10 (for reducing from M12 to M10)			
003521033	EasyZero Positioning round sleeve Ø16 (for positioning of the pots)			



Manual

Minimize set-up times
with EasyZero zero point system



EasyZero - Safety lock

Process reliability thanks to safety lock: conventional spring-loaded zero point systems have limited spring force. That is why they are often error-prone and are a safety risk. On the other hand, the EasyZero zero point system impresses with its insuperable safety lock.

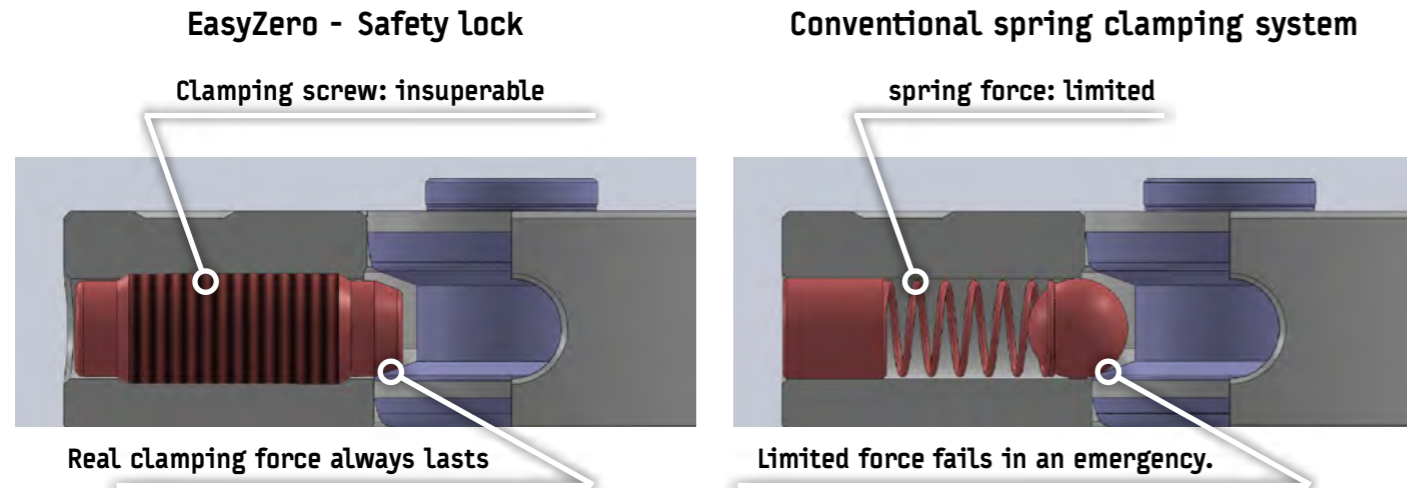

This safety lock has especially been developed for the EasyZero zero point system. It secures clamping devices and workpieces mechanically and insuperably on the machine table. An opening of the safety lock due to overload is impossible - the clamping screw or clamping stud would have to be smashed for this.

Spring force, however, is limited and fails at high machining forces and in an emergency. Dirt can also reduce the spring force and allow risky opening. This usually provokes a crash which can lead to damage to the workpiece, tool or machine and can even cause injury to the machine operator.

Therefore safety first with EasyZero safety lock:

A low crash risk minimizes the risk of injury, prevents damage to the workpiece, tool and machine and ensures precise work results.



Clamping force up to 50 kN
Turning moment max. 60Nm

Clamping screw:



EasyZero - Studs



Positioning stud:
responsible for highly precise positioning.

Orienting stud:
responsible for exact orienting to the axis.

Clamping stud:
with undersize simply useful for safe clamping.

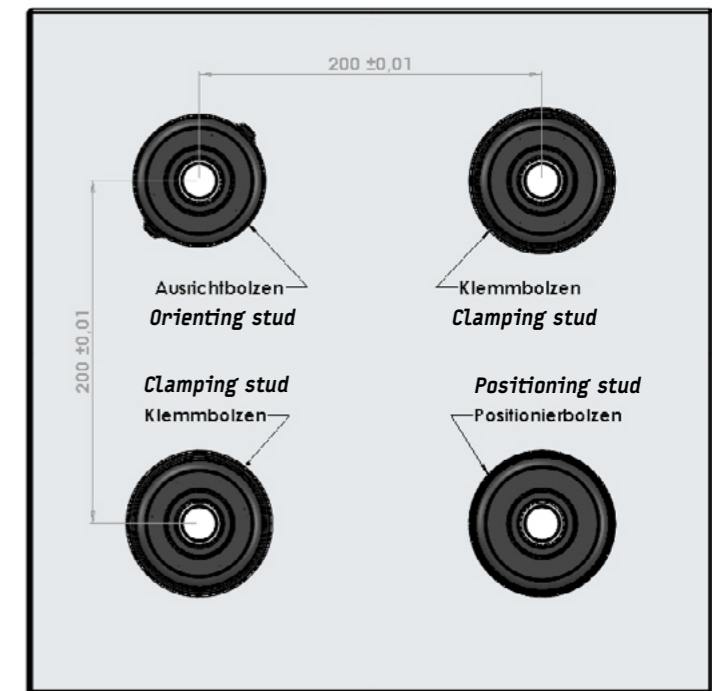

It slips easily:
minimized canting, user-friendly as well as highly precise.

- + Simple inserting
- + Repeatability < 0,005 mm

Useful in every detail!

Zero clamping system

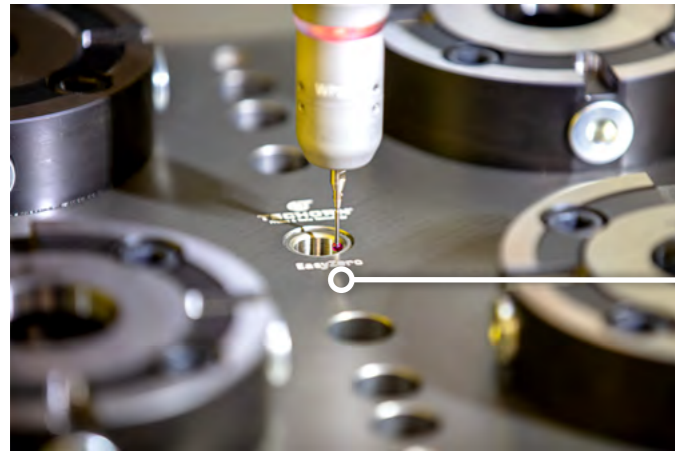

EASY centre point:
Exactly in the middle of the system, there is a hole for quick and precise recording of the centre point.

EASY laid open:
More safety from chips and dirt thanks to the open area.

EASY massively clamped:
Broad and massiv clamping surfaces make the system stable and reduce vibrations.

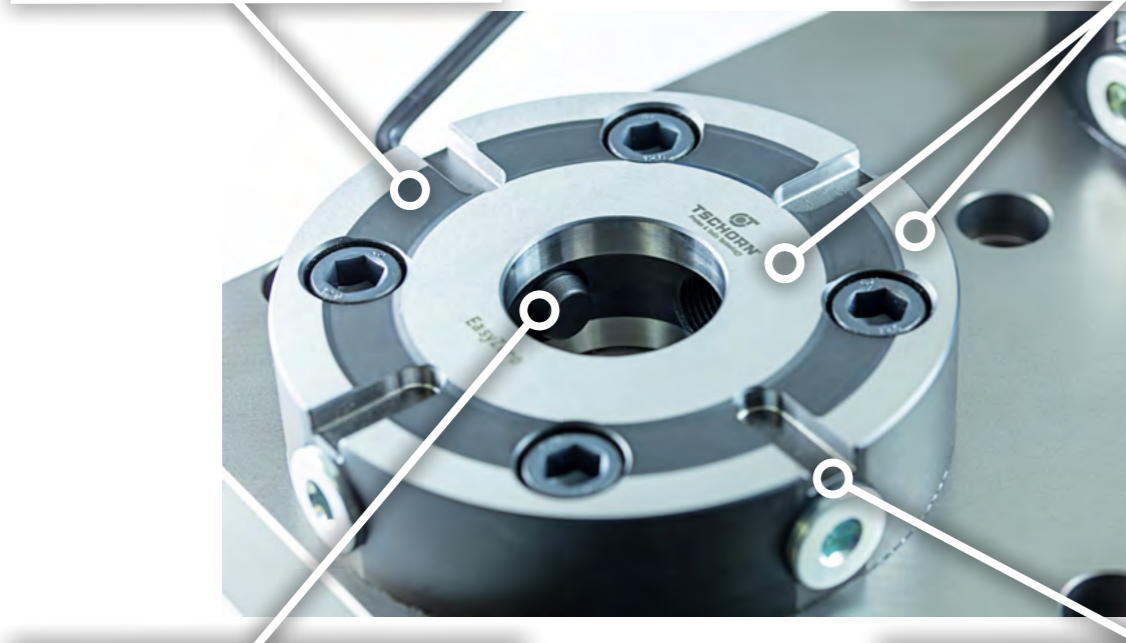

EASY powerful:
With only 60Nm torque, we reach up to 50 kN clamping force.
(Usable in 4 directions)

EASY indexed:
Precisely indexed via the indexing slots width 8 mm.

Systems and accessories

Zero clamping system



Adapter plate
4 clamping points
Art.No. 003511004



Adapter plate
2 clamping points
Art.No. 003511002

Adapter plate
1 clamping point
Art.No. 003511001



Basic system 4 pots
Art.No. 003501004



Basic system 2 pots
Art.No. 003501002

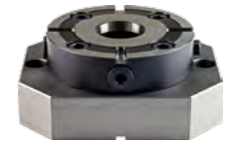

Basic system 1 pot
Art.No. 003501001



Positioning stud
Art.No. 003521001



Orienting stud
Art.No. 003521002



Clamping stud
Art.No. 003521003



Basic system 1 pot
Art-Nr. 003501001



Cover stud
Art.No. 003521011



Clamping screw
Art.No. 003521021



Cover
Art.No. 003521012

Clamping bolts



Quick setting with the clamping bolts: move each single bolt without clamping screw into the slide block of the machine table and position the bolt by hand as a stopper at the workpiece. Tighten the clamping bolt and it automatically helps you to position the workpiece.

Flexible for diverse workpiece shapes: no matter if round, oval, quadratical or even pentagonal - with the help of the clamping bolts, you can clamp all forms.



Safely fixed: the clamping screws are added from above. They clamp the workpiece powerfully and securely. A soft exchangeable brass ring avoids damages or scratches at the workpiece.

Drill-through: there is not much disturbing space under the workpiece - no clamping jaws, no base, nothing is disturbing when you drill-through your workpiece with diverse divisions of pitch circles.

The small disturbing contour enables multi-purpose machining even at places which you normally hardly reach.

Clamping bolt system FlexiClamp



You only buy what you need!

Build your own clamping system!

Full flexibility thanks to the modular principle

New, incredibly fast and individual application: FlexiClamp

Assemble your FlexiClamp clamping system with the parts you need for your machining!

The FlexiClamp bolts are a modern combination of an aluminum body and hardened steel surfaces. The bolts are available in heights of 50 and 80 mm.

The bolts are positioned and fastened using a centric screw with a hexagonal wrench while the bolt is stationary - without any undesired twisting.

You can reach any position on the machine table with the help of the transvers T-slot bar:

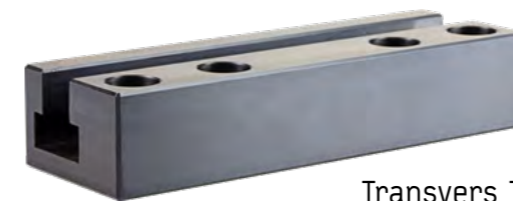

Transvers T-slot bar
Art.No. 003S00Z40



FlexiClamp is also suitable for series production, since the workpiece can be changed in just a few simple steps using the bearing clamping screw:



FlexiClamp

FlexiClamp

Decide which screw you need:

 **Art.No. 003S01000**
Standard screw for small to medium-sized series: minimized interfering contours thanks to the very flat screw head.

 **Art.No. 003S02000**
Bearing clamping screw also for large series: Faster workpiece changes due to the innovative contour of the bearing screw head.

Decide which clamping height you need:

Stable extension of the clamping height by 20 or 40 mm through a rigid extension with the same clamping screw length:



Clamping bolt height 50 mm
Art.No. 003S00050



Clamping bolt height 80 mm
Art.No. 003S00080



Clamping ring (for bearing clamping screw)
Art.No. 003S00Z22



Clamping ring standard
Art.No. 003S00Z21



Transvers T-slot bar
Art.No. 003S00Z40

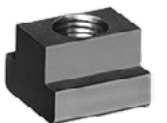

Slide block
10 - 18 mm

Order data:

Article No.	Description
003S01050	FlexiClamp Set clamping bolt M8 height 50 mm + clamping screw standard
003S01080	FlexiClamp Set clamping bolt M8 height 80 mm + clamping screw standard
003S02050	FlexiClamp Set clamping bolt M8 height 50 mm + bearing clamping screw
003S02080	FlexiClamp Set clamping bolt M8 height 80 mm + bearing clamping screw
003S00050	FlexiClamp clamping bolt M8 height 50 mm
003S00080	FlexiClamp clamping bolt M8 height 80 mm
003S01000	FlexiClamp clamping screw standard 5-25 mm
003S02000	FlexiClamp bearing clamping screw 5-25 mm
003S00Z11	FlexiClamp clamping bolt extension +20mm
003S00Z12	FlexiClamp clamping bolt extension +40mm
003S00Z21	FlexiClamp clamping ring standard
003S00Z22	FlexiClamp clamping ring for bearing clamping screw
003S00Z40	FlexiClamp transvers T-slot bar 14 mm (for suitable T-slot distances 63, 100 and 125 mm)
002080028	Slide block M8 x 10
002140301	Slide block M8 x 12
002140327	Slide block M8 x 14
002153460	Slide block M8 x 16
002153478	Slide block M8 x 18



Clamping bolts

Conventional steel design

Clamping bolts



Clamping bolt 50 mm
with thread
M10 oder M12



Clamping bolt 100 mm
with exchangeable
threaded bolt



Clamping bolt 150 mm
with exchangeable
threaded bolt

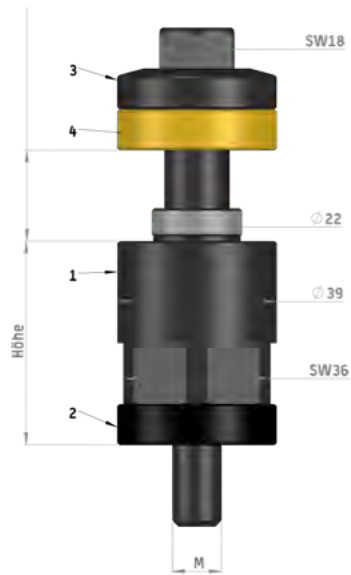

- 1 - clamping bolt
- 2 - spring washer
- 3 - clamping screw
- 4 - clamping ring
- 5 - threaded bolt

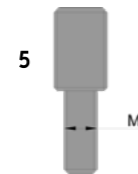

Type:

Flexible clamping tool for direct clamping on the machine table with direct fixation in the T-slot. Precise tolerance classes guarantee parallel clamping to the machine table. For the bolts with length 100 mm and 150 mm, exchangeable threaded bolts are available. The clamping ring prevents a damage of the workpiece.

Almost all types of flat workpieces can be clamped powerfully and precisely with these clamping bolts. The standard clamping range is 8-40 mm. With the clamping screws (available as spare part) it can be widened to a maximum of 87 mm.



Scope of delivery for height 50 mm:

Clamping bolts with fixed thread, ring & clamping screw with clamping ring

Article No.	Description	Height	Thread
003000050	Clamping bolt	50 mm	M10
003M12050	Clamping bolt	50 mm	M12

Scope of delivery for height 100 mm/150 mm:

Clamping bolts, threaded bolt M10, ring & clamping ring with clamping screw

Article No.	Description	Height	Thread
003000100	Clamping bolt	100 mm	M10
003000150	Clamping bolt	150 mm	M10

Spare parts for clamping bolts

Article No.	Description	Thread
003000Z00	Washer	-
003000Z02	Clamping ring	-
003000Z01	Clamping screw	8 mm - 40 mm
003000Z03	Clamping screw	40 mm - 67 mm
003000Z04	Clamping screw	65 mm - 87 mm
003000M10	Threaded bolt	M10
003000M12	Threaded bolt	M12
003000M14	Threaded bolt	M14
003000M16	Threaded bolt	M16

Set of clamping bolts

Delivery includes:

3 pcs. clamping bolts length 50 or 100, 3 pcs. clamping screw 40-67, 3 pcs. clamping screw 65-87, 1 pcs. The set is in a high-quality wooden case.

Article No.	Description	Height	Thread
003990050	Clamping bolt set	50 mm	M10
003990100	Clamping bolt set	100 mm	M10



Clamping bolts



Your sales contact



Maik Schoch



☎ +49 7181 606986 7
 @ maik.schoch@tschorn-gmbh.de



Sina Kortmann



☎ +49 7181 606986 7
 @ sina.kortmann@tschorn-gmbh.de

Repair service



Crashed?

All our devices can be repaired.

Our worldwide resellers support you for any repair or service question.

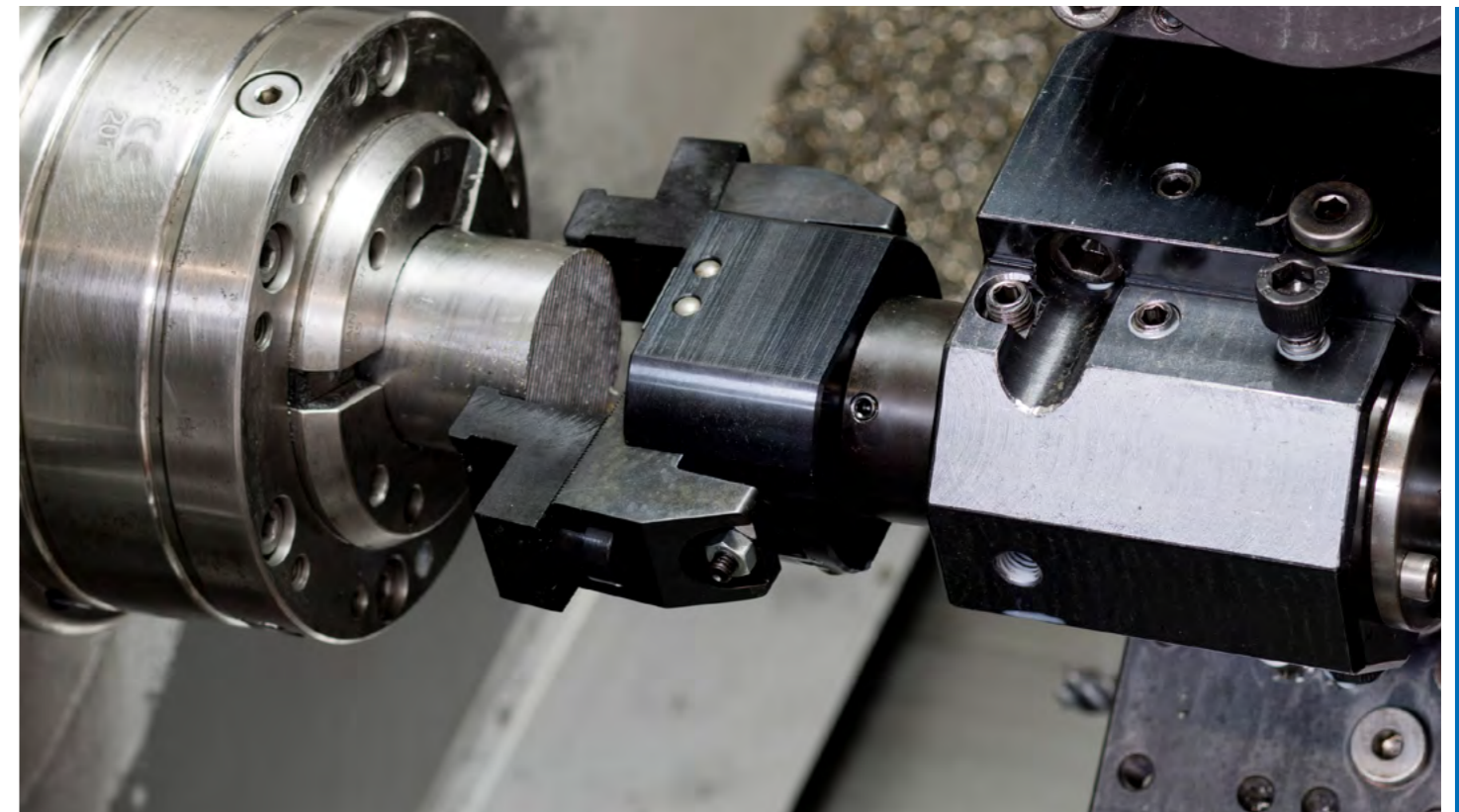

Automation

Automate your lathe!

Bar grippers



You do not want to stand permanently at the machine and insert material?

A bar gripper does this work for you. It automates your lathe - now your lathe is a fully automated production centre and saves money and time.

Easy and quickly, the bar gripper pulls the raw material and the machine goes on with the production directly. You do not need any expensive employees who add the material.

The bar gripper is available in diverse shank sizes - this is why you can use it on every lathe. Thanks to the flexible reversible jaws, it is usable in a wide clamping range which enables a wide range of applications.



Bar grippers

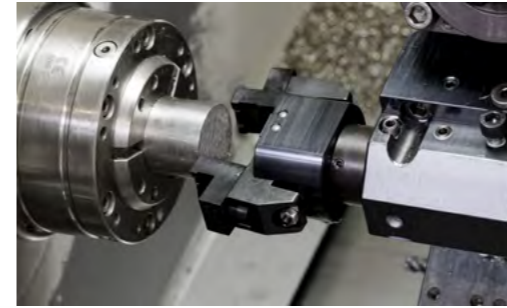

Position the bar gripper in Z axis in front of the bar.

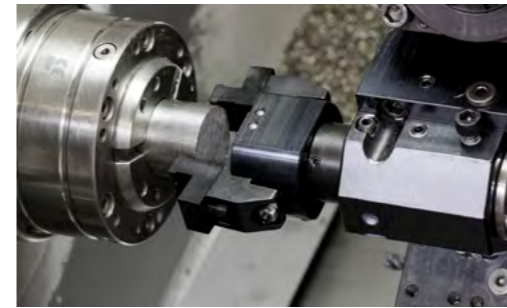

Now move onto the bar and open the chuck.



Pull the bar to the desired position in Z.

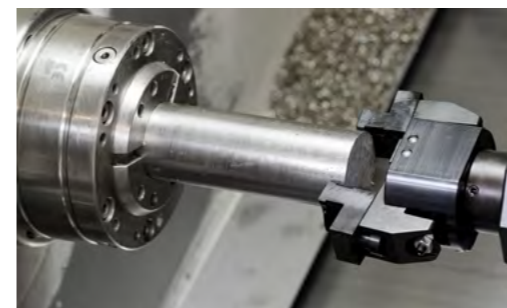

Close the chuck.



Move the bar gripper in Z direction off the bar and start machining.

Important note of safety:

Please use appropriate reducing tubes in your spindle and make sure that the rotating bar does not protrude out of the machine.

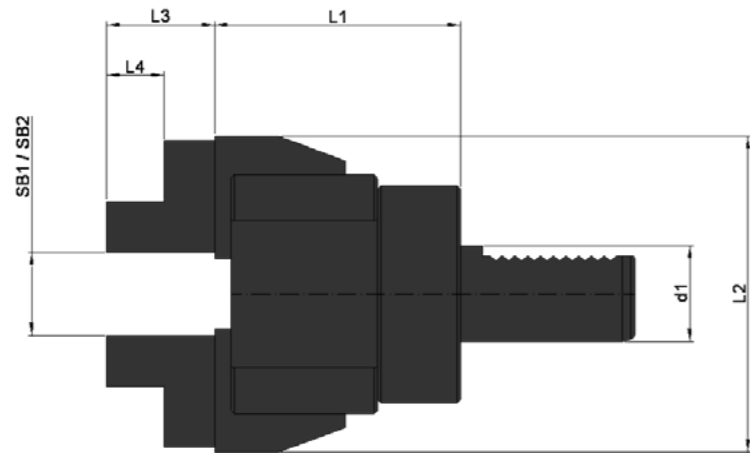

Delivery includes:

Bar gripper, set of reversible clamping jaws

Bar gripper with VDI shank

Article No.	Description	Shank	SB1	SB2	L1	L2	L3	L4
00STG2000	Bar gripper	VDI20	6-45	45-100	77	99	34	18
00STG3000	Bar gripper	VDI30	6-45	45-100	77	99	34	18
00STG4000	Bar gripper	VDI40	6-56	56-110	79	111	34	18
00STG5000	Bar gripper	VDI50	6-56	56-110	79	111	34	18

Bar gripper with cylindrical shank

Article No.	Description	Shank	SB1	SB2	L1	L2	L3	L4
00STG20ZY	Bar gripper	Ø20	6-45	45-100	77	99	34	18
00STG25ZY	Bar gripper	Ø25	6-45	45-100	77	99	34	18
00STG32ZY	Bar gripper	Ø32	6-45	45-100	77	99	34	18
00STG40ZY	Bar gripper	Ø40	6-56	56-110	79	111	34	18

Spare parts

Article No.	Description
00STG0001	Set of reversible clamping jaws



Assembly

Assembly system

The practical assistant for quick and easy tool changes!

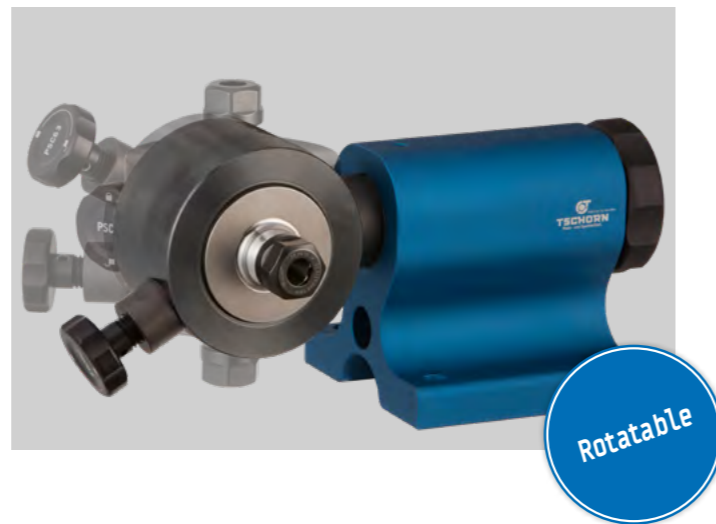

The assembly system is flexible: all popular adapter types and sizes are available and offer a quick and precise handling of your tools. The change of the adapters is easy and simple – you can mount your tools holders within seconds.

The assembly system is not only time-saving but also helps you to have long-lasting tool holders: thanks to our unique technology, the tool holder is not clamped at its precise conus - the conus is free. This is safer for your tool holders and no damages ensure a precise processing of the parts you have to manufacture.

As the adapter is **rotatable**, you can turn your tool at any time within seconds to the desired position. This enables **ergonomic** and healthy working conditions.

Also **job safety** is important. All adapters have been developed to guarantee form-closed and safe fixation of the tool holders. It is not possible to slip off, even not with a lot of power. This prevents accidents and injuries.



Assembly system

Assembly system

Assembly system

Assembly system

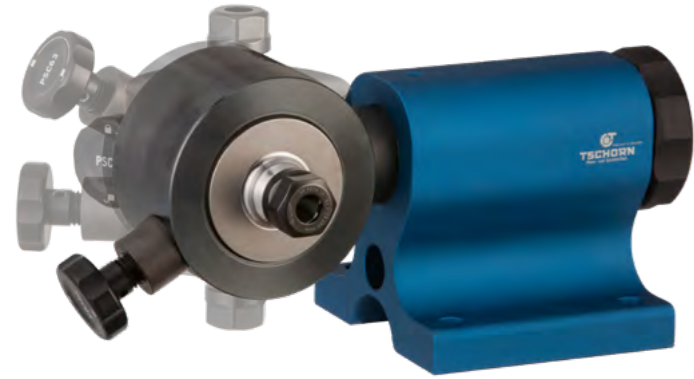

Modular & Rotatable

DIN69880 VDI



DIN69871 SK



DIN69893 HSK-A



ISO26623 PSC



- Type**
- aluminum body
 - 4 x 90° revolving
 - modular tool holders made of steel
 - quick and easy exchange system
 - high flexibility
 - interlocking fixation of the tools
 - conus cannot be damaged
 - minimum space required
 - optimal ergonomics
 - quick and safe tool exchange within seconds

Closed —

Open —



Assembly system basic unit

Article No.	Description
004000000	Assembly system basic unit

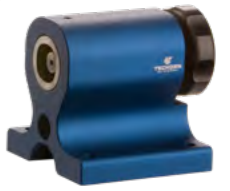

Assembly system adaptors

Article No.	Description	Norm	Size
004100130	Adaptor	DIN69871, JIS B	SK30
004100140	Adaptor	DIN69871, JIS B	SK40
004100150	Adaptor	DIN69871, JIS B	SK50
004100132	Adaptor	JIS B double contact	BT30+
004100142	Adaptor	JIS B double contact	BT40+
004100540	Adaptor	DIN69893	HSK40-A
004100550	Adaptor	DIN69893	HSK50-A
004100563	Adaptor	DIN69893	HSK63-A
004100580	Adaptor	DIN69893	HSK80-A
004100510	Adaptor	DIN69893	HSK100-A
004100620	Adaptor	DIN69880	VDI20
004100625	Adaptor	DIN69880	VDI25
004100630	Adaptor	DIN69880	VDI30
004100640	Adaptor	DIN69880	VDI40
004100650	Adaptor	DIN69880	VDI50
004100C32	Adaptor	ISO26623	PSC32
004100C40	Adaptor	ISO26623	PSC40
004100C50	Adaptor	ISO26623	PSC50
004100C63	Adaptor	ISO26623	PSC63
004100C80	Adaptor	ISO26623	PSC80



Assembly device

Assembly device



Assembly device with tool holder made out of steel for **safe clamping** of your tool holders. Thanks to a unique technology, the tool holders are not clamped at their precise cones. So the cones are free. This is unique safe for your tool holders and ensures **precise processing** of the parts you have to manufacture.



Turn your tool at any time within seconds into the desired position. Ergonomic and healthy working conditions thanks to the **practical rotating function**.

Assembly device

The assembly device is **stepless rotatable** at 45° to the left and 45° to the right.



The assembly device is available at the sizes SK30, SK40, HSK63 as well as VDI25, VDI30 and VDI40. Other sizes are available on request.



Article No.	Description	Norm	Size
004300130	Assembly device	DIN69871, JIS B	SK30
004300140	Assembly device	DIN69871, JIS B, DIN2080	SK40
004300563	Assembly device	DIN69893	HSK63
004300625	Assembly device	DIN69880	VDI25
004300630	Assembly device	DIN69880	VDI30
004300640	Assembly device	DIN69880	VDI40

Other sizes are available on request.

Your sales contact



Maik Schoch



+49 7181 606986 7
@ maik.schoch@tschorn-gmbh.de



Sina Kortmann



+49 7181 606986 7
@ sina.kortmann@tschorn-gmbh.de



Service / Contact

 **Repair service**



Crashed?
All our devices can be repaired.
Our worldwide resellers support you for any repair or service question.



Tool holders

Saw blade holders

Application:

For precise holding of saw blades.

Type:

With parallel shank for a fixture in plain chuck jaws, high true running accuracy.

Also available as a set

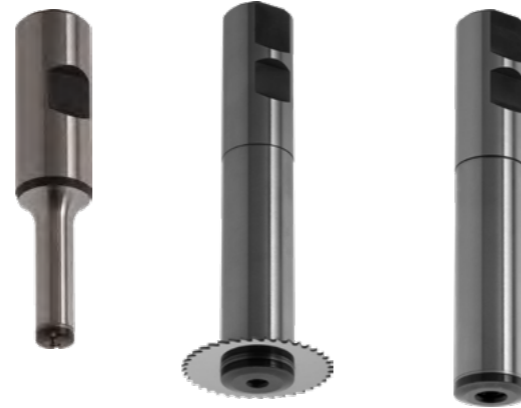

For the precise use of your saw blade holder, please pay attention to the correct insertion of the washer (see picture below). When choosing your cutting data, e.g. cutting speed and the feed rate, please take into account that your saw blade is only held by surface pressure. Too high cutting data or a dull saw blade can lead to hooking or stopping of the saw blade which can result in damages at your workpiece, saw blade, saw blade holder or even at your machine.

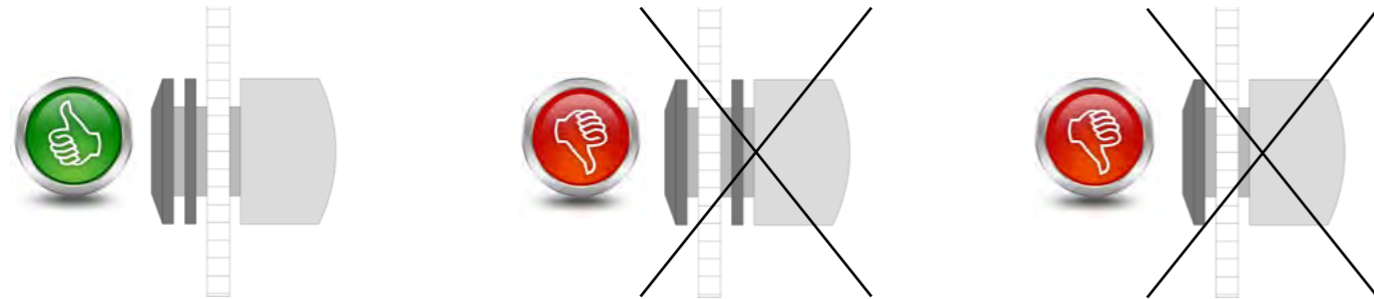

Article No.	Description	L1	L2	D1	D2	D3
0000S1020	Saw blade holder for saw blade Ø20	75	30	Ø10	Ø10	Ø5
0000S2020	Saw blade holder for saw blade Ø20	90	30	Ø20	Ø10	Ø5
0000S1025	Saw blade holder for saw blade Ø25	88	48	Ø10	Ø13	Ø8
0000S2025	Saw blade holder for saw blade Ø25	100	42	Ø20	Ø13	Ø8
0000S1032	Saw blade holder for saw blade Ø32	93	53	Ø10	Ø16	Ø8
0000S2032	Saw blade holder for saw blade Ø32	105	53	Ø20	Ø16	Ø8
0000S1040	Saw blade holder for saw blade Ø40	100	60	Ø10	Ø19,5	Ø10
0000S2040	Saw blade holder for saw blade Ø40	110	60	Ø20	Ø19,5	Ø10
0000S1650	Saw blade holder for saw blade Ø50	126	78	Ø16	Ø24,5	Ø13
0000S2550	Saw blade holder for saw blade Ø50	136	78	Ø25	Ø24,5	Ø13
0000S1663	Saw blade holder for saw blade Ø63	126	78	Ø16	Ø24,5	Ø16
0000S2563	Saw blade holder for saw blade Ø63	136	78	Ø25	Ø24,5	Ø16
0000S2080	Saw blade holder for saw blade Ø80	142	92	Ø20	Ø34	Ø22
0000S2580	Saw blade holder for saw blade Ø80	150	92	Ø25	Ø34	Ø22
0000S2010	Saw blade holder for saw blade Ø100	142	92	Ø20	Ø39,5	Ø22
0000S2510	Saw blade holder for saw blade Ø100	150	92	Ø25	Ø39,5	Ø22



Saw blade holder set

Saw blade holders in the following sizes: Ø20, Ø25, Ø32, Ø40, Ø50 and Ø63 with allen key in a suitcase.

Article No.	Description
0000S0020	Saw blade holder set



Spare parts

Safe use of the saw blade holders:

The saw blade stops rotation when the cutting force is greater than the holding force. This can happen because chips have got stuck, the saw blade is worn or blunt or the cutting values have been selected inappropriately.

As the spindle continues rotation, a stopped saw blade can inevitably result in the screw being screwed into the saw blade holder and consequently shearing off the screw head completely.

If your saw blade or the screw is broken, please check whether the saw blade holder, the screw or the washer are damaged. If in doubt, we also recommend replacing the washer, as it protects and ensures the precision of your saw blade holder.

Article No.	Description	Size
0101S2020	Spare spring washer for saw blade holder	Ø20
0101S2025	Spare spring washer for saw blade holder	Ø25
0101S2032	Spare spring washer for saw blade holder	Ø32
0101S2040	Spare spring washer for saw blade holder	Ø40
0101S2550	Spare spring washer for saw blade holder	Ø50
0101S2563	Spare spring washer for saw blade holder	Ø63
0101S4080	Spare spring washer for saw blade holder	Ø80
0101S4010	Spare spring washer for saw blade holder	Ø100
0102S2020	Spare screw for saw blade holder	Ø20
0102S2025	Spare screw for saw blade holder	Ø25
0102S2032	Spare screw for saw blade holder	Ø32
0102S2040	Spare screw for saw blade holder	Ø40
0102S2550	Spare screw for saw blade holder	Ø50
0102S2563	Spare screw for saw blade holder	Ø63
0102S4080	Spare screw for saw blade holder	Ø80
0102S4010	Spare screw for saw blade holder	Ø100

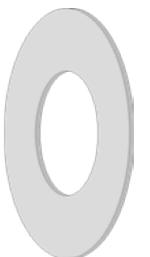

Art. No.	Saw blades rough
PASBG040100	Saw blade rough VHM-B 40x1,00x10-Z32
PASBG040120	Saw blade rough VHM-B 40x1,20x10-Z32
PASBG040150	Saw blade rough VHM-B 40x1,50x10-Z32
PASBG040160	Saw blade rough VHM-B 40x1,60x10-Z32
PASBG040180	Saw blade rough VHM-B 40x1,80x10-Z32
PASBG040200	Saw blade rough VHM-B 40x2,00x10-Z32
PASBG040250	Saw blade rough VHM-B 40x2,50x10-Z32
PASBG040300	Saw blade rough VHM-B 40x3,00x10-Z32
PASBG040400	Saw blade rough VHM-B 40x4,00x10-Z32
PASBG040500	Saw blade rough VHM-B 40x5,00x10-Z32
PASBG040600	Saw blade rough VHM-B 40x6,00x10-Z32
PASBG050040	Saw blade rough VHM-B 50x0,40x13-Z48
PASBG050050	Saw blade rough VHM-B 50x0,50x13-Z48
PASBG050060	Saw blade rough VHM-B 50x0,60x13-Z48
PASBG050070	Saw blade rough VHM-B 50x0,70x13-Z40
PASBG050080	Saw blade rough VHM-B 50x0,80x13-Z40
PASBG050090	Saw blade rough VHM-B 50x0,90x13-Z40
PASBG050100	Saw blade rough VHM-B 50x1,00x13-Z40
PASBG050120	Saw blade rough VHM-B 50x1,20x13-Z40
PASBG050150	Saw blade rough VHM-B 50x1,50x13-Z32
PASBG050160	Saw blade rough VHM-B 50x1,60x13-Z32
PASBG050180	Saw blade rough VHM-B 50x1,80x13-Z32
PASBG050200	Saw blade rough VHM-B 50x2,00x13-Z32
PASBG050250	Saw blade rough VHM-B 50x2,50x13-Z32
PASBG050300	Saw blade rough VHM-B 50x3,00x13-Z24
PASBG050400	Saw blade rough VHM-B 50x4,00x13-Z24
PASBG050500	Saw blade rough VHM-B 50x5,00x13-Z24
PASBG050600	Saw blade rough VHM-B 50x6,00x13-Z20
PASBG063040	Saw blade rough VHM-B 63x0,40x16-Z64
PASBG063050	Saw blade rough VHM-B 63x0,50x16-Z64
PASBG063060	Saw blade rough VHM-B 63x0,60x16-Z48
PASBG063070	Saw blade rough VHM-B 63x0,70x16-Z48
PASBG063080	Saw blade rough VHM-B 63x0,80x16-Z48
PASBG063090	Saw blade rough VHM-B 63x0,90x16-Z48
PASBG063100	Saw blade rough VHM-B 63x1,00x16-Z48
PASBG063120	Saw blade rough VHM-B 63x1,20x16-Z40
PASBG063150	Saw blade rough VHM-B 63x1,50x16-Z40
PASBG063160	Saw blade rough VHM-B 63x1,60x16-Z40
PASBG063180	Saw blade rough VHM-B 63x1,80x16-Z40
PASBG063200	Saw blade rough VHM-B 63x2,00x16-Z40
PASBG063250	Saw blade rough VHM-B 63x2,50x16-Z32
PASBG063300	Saw blade rough VHM-B 63x3,00x16-Z32
PASBG063400	Saw blade rough VHM-B 63x4,00x16-Z32
PASBG063500	Saw blade rough VHM-B 63x5,00x16-Z24
PASBG063600	Saw blade rough VHM-B 63x6,00x16-Z24
PASBG080060	Saw blade rough VHM-B 80x0,60x22-Z64
PASBG080070	Saw blade rough VHM-B 80x0,70x22-Z64
PASBG080080	Saw blade rough VHM-B 80x0,80x22-Z64
PASBG080090	Saw blade rough VHM-B 80x0,90x22-Z48
PASBG080100	Saw blade rough VHM-B 80x1,00x22-Z48
PASBG080120	Saw blade rough VHM-B 80x1,20x22-Z48
PASBG080150	Saw blade rough VHM-B 80x1,50x22-Z48
PASBG080160	Saw blade rough VHM-B 80x1,60x22-Z48
PASBG080180	Saw blade rough VHM-B 80x1,80x22-Z40
PASBG080200	Saw blade rough VHM-B 80x2,00x22-Z40
PASBG080250	Saw blade rough VHM-B 80x2,50x22-Z40
PASBG080300	Saw blade rough VHM-B 80x3,00x22-Z40
PASBG080400	Saw blade rough VHM-B 80x4,00x22-Z32
PASBG080500	Saw blade rough VHM-B 80x5,00x22-Z32
PASBG080600	Saw blade rough VHM-B 80x6,00x22-Z32
PASBG100060	Saw blade rough VHM-B100x0,60x22Z=80
PASBG100070	Saw blade rough VHM-B100x0,70x22Z=80
PASBG100080	Saw blade rough VHM-B100x0,80x22Z=64
PASBG100090	Saw blade rough VHM-B100x0,90x22Z=64
PASBG100100	Saw blade rough VHM-B100x1,00x22Z=64
PASBG100120	Saw blade rough VHM-B100x1,20x22Z=64
PASBG100150	Saw blade rough VHM-B100x1,50x22Z=48
PASBG100160	Saw blade rough VHM-B100x1,60x22Z=48
PASBG100180	Saw blade rough VHM-B100x1,80x22Z=48

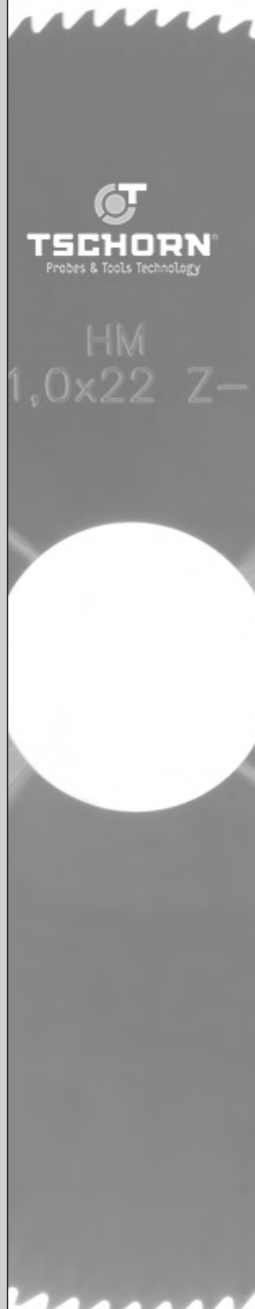

Art. No.	Saw blades rough
PASBG100200	Saw blade rough VHM-B100x2,00x22Z=48
PASBG100250	Saw blade rough VHM-B100x2,50x22Z=48
PASBG100300	Saw blade rough VHM-B100x3,00x22Z=40
PASBG100400	Saw blade rough VHM-B100x4,00x22Z=40
PASBG100500	Saw blade rough VHM-B100x5,00x22Z=40
PASBG100600	Saw blade rough VHM-B100x6,00x22Z=32



Impossible to produce external threads quicker!

Process-reliable

Precise

Quick

Impossible to produce external threads quicker! Our video shows the comparison: with the help of our die holder, you cut M16 threads with 50 mm length in only 12 seconds. This is **3 times faster** as conventional thread chasing.

Additionally: a threading die has many blades - conventional thread chasing only one. This is why a defect blade at the die does not matter anymore. This optimizes your **process stability** extremely.

The die holder enables **precise and cylindrical threads** as you cut the thread in the die cylindrical. While chasing, the cutting pressure operates against the workpiece which can lead to vibrations, to evasion or even to conical threads.

The die holder is internally cooled: the coolant supply ensures that the workpiece is **permanently surrounded by coolant**. This leads to high-quality threads and as the coolant flushes away all chips.

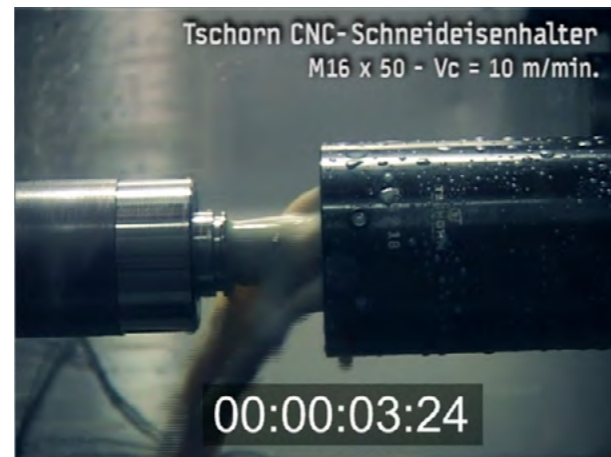
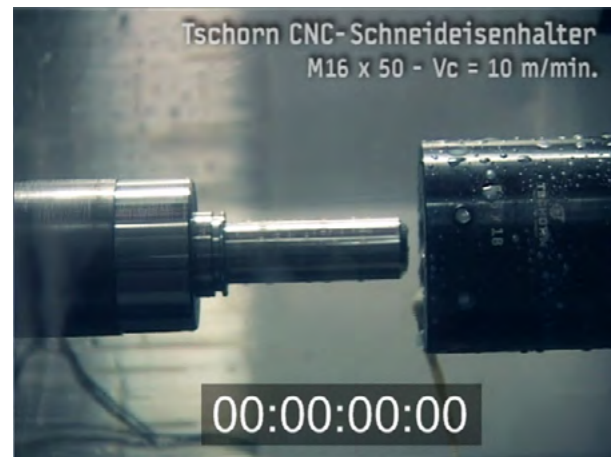

Also available as cylindrical shank, SK40 or HSK63.

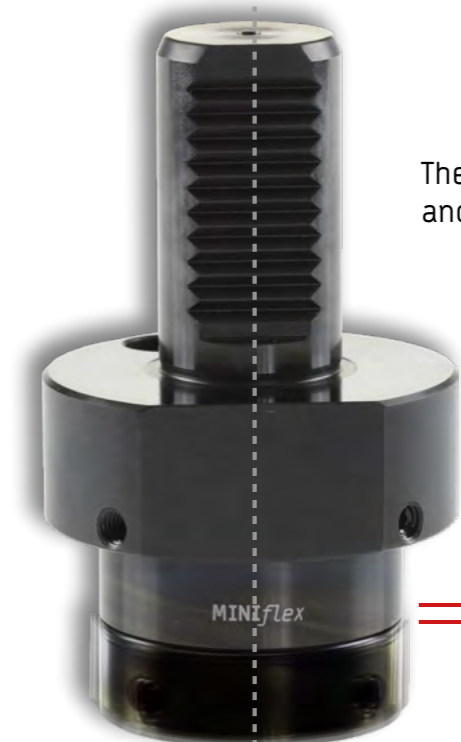

The **MINIflex**-holder has an axial and radial damping.

axial flexible damping

radial flexible damping

The damping compensates imprecisions of the control or run-out/positioning errors of a reamer.

Modular



External threading



Tapping



Reaming

Die holders/MINIflex



Base holders



Cylindrical shank



DIN69880 VDI



DIN69871 SK40



DIN69893 HSK63

Article No.	Description	Shank	Length
OOSFLOZ20	Base holder MINIFlex	Ø20	55 mm
OOSFLOZ25	Base holder MINIFlex	Ø25	55 mm
OOSFLOV20	Base holder MINIFlex DIN69880	VDI20	55 mm
OOSFLOV30	Base holder MINIFlex DIN69880	VDI30	55 mm
OOSFLOV40	Base holder MINIFlex DIN69880	VDI40	55 mm
OOSFLOS40	Base holder MINIFlex DIN69871	SK40	58 mm
OOSFLOH63	Base holder MINIFlex DIN69893	HSK63	71 mm



Extension

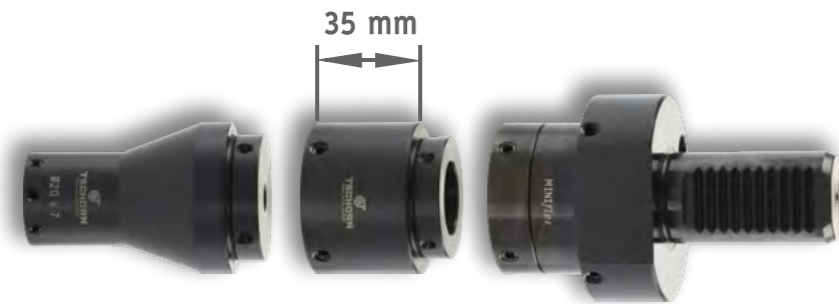

Article No.	Description	Shank	Length
O0SEH4035	Extension	-	35 mm



Exchange modules

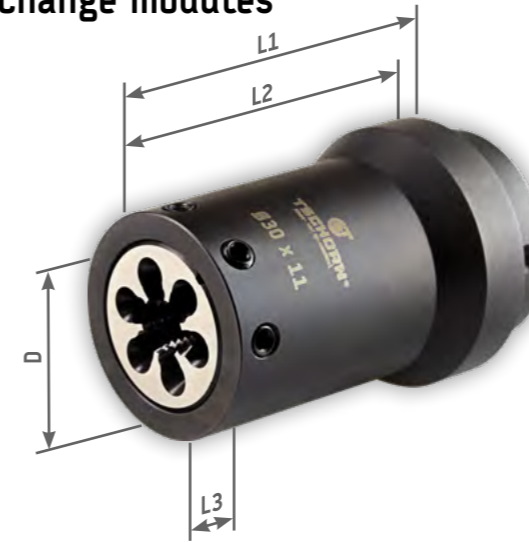

D = Ø of the die
L1 = Clamping length
L2 = Usable length
L3 = Width die

Please note:
With an extension, you can extend the usable length about 35 mm.

Article No.	Description	D	L1	L2	L3	Thread
O0SEH1605	Exchange module	16	75	74	5	M1-M2,5
O0SEH2005	Exchange module	20	75	74	5	M3-M4
O0SEH2007	Exchange module	20	75	74	7	M5-M6
O0SEH2509	Exchange module	25	75	74	9	M7-M9
O0SEH3011	Exchange module	30	75	74	11	M10
O0SEH3814	Exchange module	38	75	74	14	M12-M14
O0SEH4518	Exchange module	45	85	84	18	M16-M20
ER modules:						
O0SEHER25	Exchange module ER25	Ø2 - Ø16	43			
O0SEHER32	Exchange module ER32	Ø2 - Ø20	43			

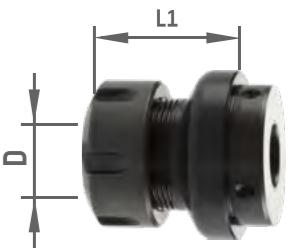

High performance dies

High performance dies
DIN EN 22568
Metric ISO thread DIN13



Article No.	Description	d	P mm	Ø D x E mm	n
PSE001M0200	Die HSSE 6g	M2	0,4	16x5	4
PSE001M0300	Die HSSE 6g	M3	0,5	20x5	5
PSE001M0400	Die HSSE 6g	M4	0,7	20x5	5
PSE001M0500	Die HSSE 6g	M5	0,8	20x7	5
PSE001M0600	Die HSSE 6g	M6	1	20x7	5
PSE001M0800	Die HSSE 6g	M8	1,25	25x9	5
PSE001M1000	Die HSSE 6g	M10	1,5	30x11	5
PSE001M1200	Die HSSE 6g	M12	1,75	38x14	5
PSE001M1600	Die HSSE 6g	M16	2	45x18	5
PSE001M2000	Die HSSE 6g	M20	2,5	45x18	5

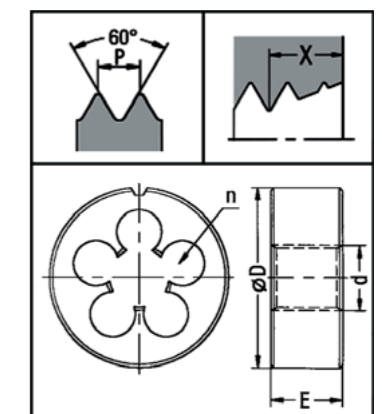

$X = 2.25 * P$

Die holders/MINIFlex

Die holders/MINIFlex

Your sales contact



Maik Schoch



+49 7181 606986 7
@ maik.schoch@tschorn-gmbh.de



Sina Kortmann



+49 7181 606986 7
@ sina.kortmann@tschorn-gmbh.de

Repair service



Crashed?

All our devices can be repaired.

Our worldwide resellers support you for any repair or service question.

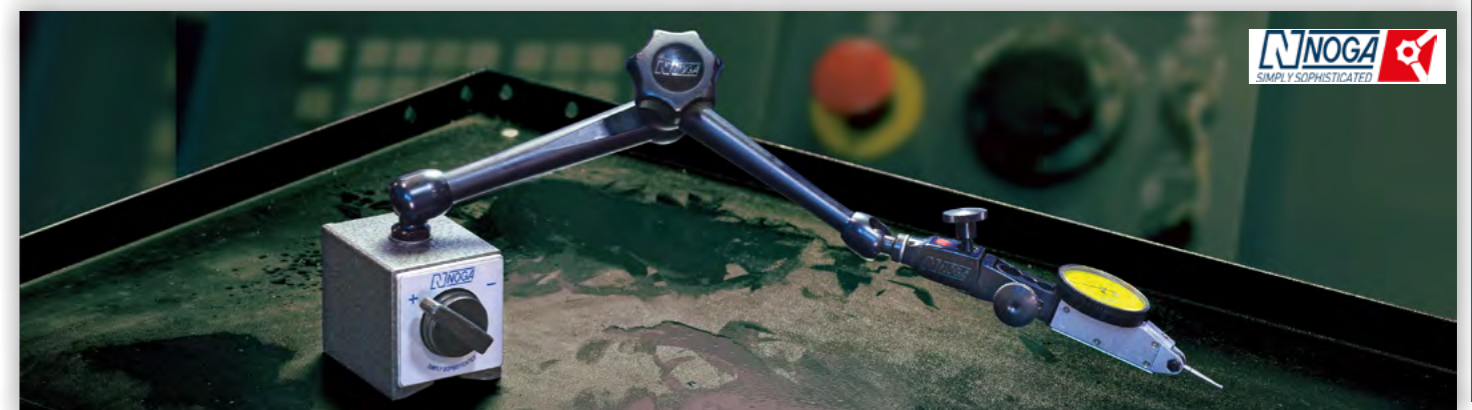

Partner products

NOGA measuring arms

Version:

- movable in all directions
- extremely stable mech. execution
- central clamping mechanism
- easily and quickly adjustable
- fine adjustment at the top with universal dial gauge holder
- optionally with or without magnetic foot



Article No.	Description	Connection (below)	L1	L2	Arm length (total)	Magnet (L / B / H / force)
PANNF6103	NOGA measuring arm	Magnet	56	51	178	40 / 30 / 35 / 320N
PANNF6013	NOGA measuring arm	M5	56	51	178	-
PANDG6103	NOGA measuring arm	Magnet	110	101	282	60 / 50 / 55 / 800N
PANDG6013	NOGA measuring arm	M8	110	101	282	-
PANMG6103	NOGA measuring arm	Magnet	133	113	317	60 / 50 / 55 / 800N
PANMG6013	NOGA measuring arm	M8	133	113	317	-
PANMA6103	NOGA measuring arm	Magnet	287	223	580	120 / 50 / 55 1300N
PANMA6013	NOGA measuring arm	M10x1.25	287	223	580	-
PANDG1000	NOGA dial gauge 0,01 mm					
0017C2098	TSCHORN lever gauge 0,01 mm					



TSCHORN lever gauge
Art.-Nr. 0017C2098

pairee Collet chucks system ER according to DIN6499 B

Advantages:

- German collet steel
- durable
- finely deburred
- Concentricity < 6µm

Information:
XXX= clamping Ø
e.g.: Ø1,0 = 010

Article No.	Description	Size	Sealed	clamping Ø
PAJOE11XXX	Collet chuck DIN6499 B	ER11	no	Ø1,0 - Ø7,0
PAJOE16XXX	Collet chuck DIN6499 B	ER16	no	Ø1,0 - Ø11,0
PAJOE20XXX	Collet chuck DIN6499 B	ER20	no	Ø2,0 - Ø13,0
PAJOE25XXX	Collet chuck DIN6499 B	ER25	no	Ø2,0 - Ø16,0
PAJOE32XXX	Collet chuck DIN6499 B	ER32	no	Ø2,0 - Ø20,0
PAJOE40XXX	Collet chuck DIN6499 B	ER40	no	Ø3,0 - Ø26,0



Piranha centering vises

PIRANHA-CLAMP Snapper: the most snappish!
The centering vise for roughing

Advantages:

- Minimal material loss at 3 mm clamping depth
- Clamping of raw parts without predetermination
- High repeatability: 0.01 mm

Article No.	Description	Size	Clamping range
PAP540362	Centering vise Snapper	170	5 mm - 118 mm
PAP540446	Centering vise Snapper (+10 mm)	170	5 mm - 118 mm
PAP540401	Centering vise Snapper	300	5 mm - 238 mm
PAP540447	Centering vise Snapper (+10 mm)	300	5 mm - 238 mm



PIRANHA-CLAMP Gepard: the quickest!
The centering vise for finishing

Advantages:

- Quick changing system for jaws within seconds
- Replaceable Snapper jaws (the snappy ones!)
- High precision coated guide pillars

Please note:
A wide selection of different jaws is available!

Artikel-Nr.	Description	Size	Clamping range
PAP540444	Centering vise Gepard	170	0 mm - 160 mm
PAP540400	Centering vise Gepard	300	0 mm - 250 mm
PAP551018	Set top jaws ALUMINIUM M 50x98x41 mm	170	0 mm - 160 mm
PAP551020	Set top jaws ALUMINIUM M 50x131x51 mm	300	0 mm - 250 mm
PAP551033	Set top jaws STEEL M 50x98x41 mm	170	0 mm - 160 mm
PAP551046	Set top jaws STEEL M 50x131x51 mm	300	0 mm - 250 mm
PAP551009	Set top jaws Snapper short 50x98x22 mm	170	7 mm - 71 mm
PAP551007	Set top jaws Snapper short 50x131x22 mm	300	7 mm - 154 mm



Tschorn GmbH

Dieselstraße 8
73660 Urbach, Germany

General manager: Ralf Tschorn, Alexandra Tschorn
Shareholder: Ralf Tschorn



Images:

These images are subject to copyright:
Made in Germany: © jokatoons - Fotolia.com

Our general terms can be found on our website: www.tschorn-gmbh.de.

Technical modifications subject to change.

Copyright

All rights reserved. All pictures, graphics, images, texts, audio-, video- and animated data of this catalogue are subject to copyright or other rights to protect intellectual property. Copying, editing, changing or using this data in other electronic or printed publication is subject to prior explicit approval of the Tschorn GmbH.